



ESSENTIAL INFORMATION

BUILD INSTRUCTIONS
CHECKING YOUR PCB & FAULT-FINDING
MECHANICAL DETAILS
HOW THE KIT WORKS

MASTER THE ART OF SOLDERING WITH THIS

REAR BIKE LIGHT KIT

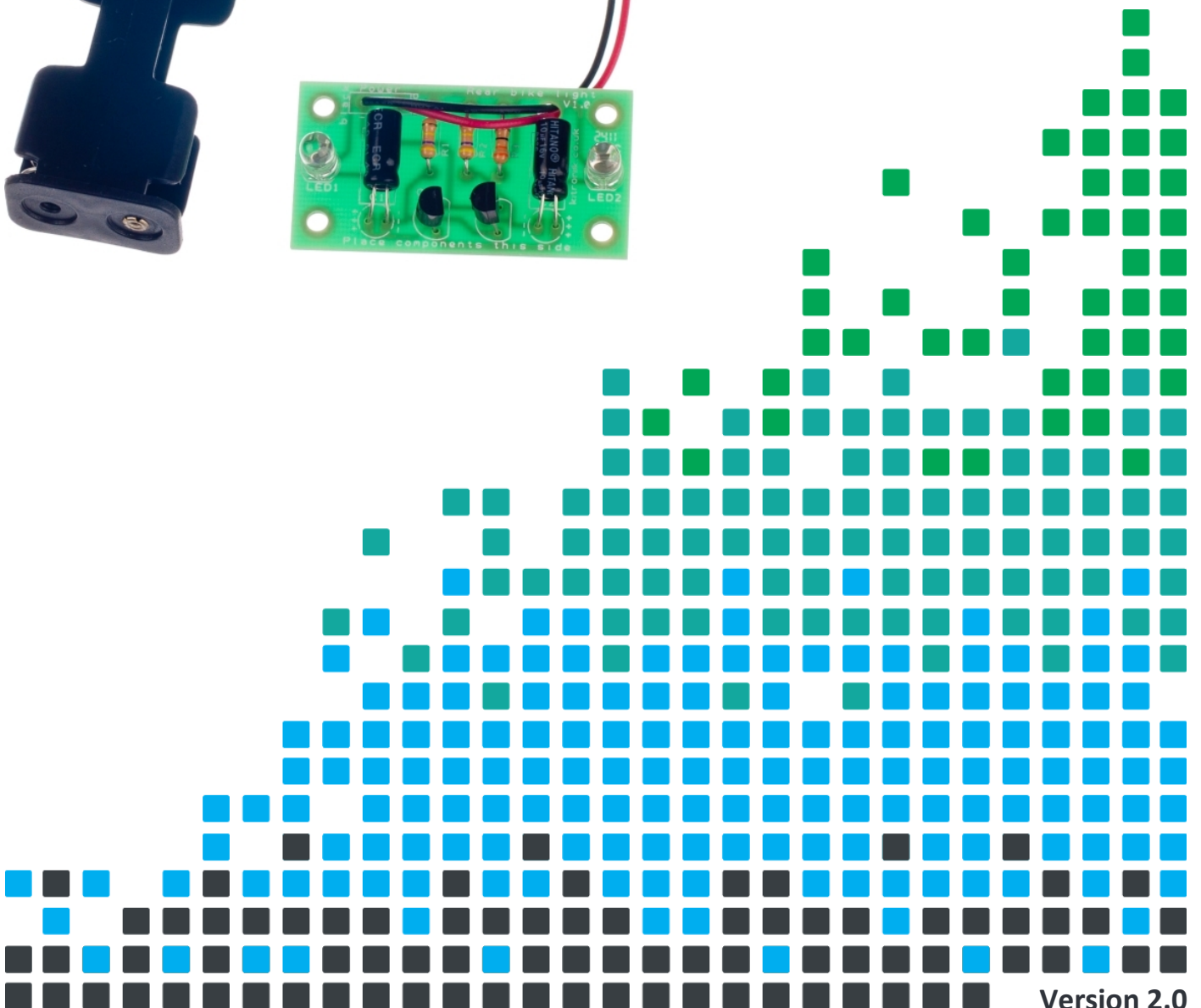
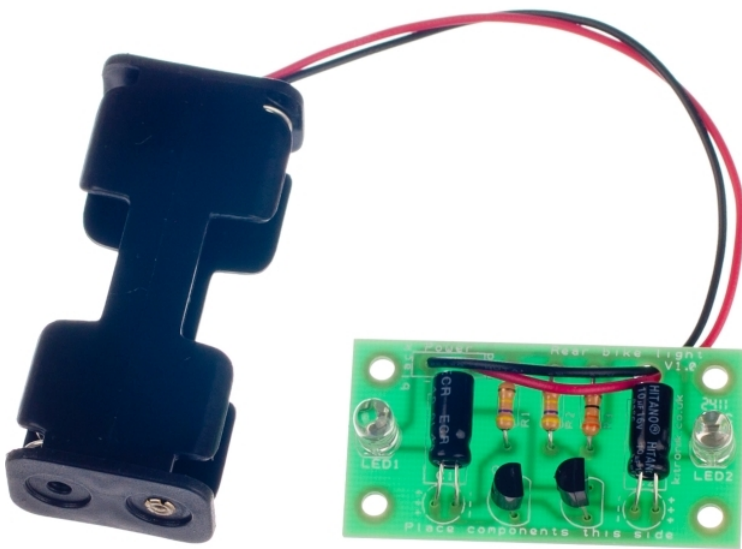

Version 2.0

Build Instructions

Before you start, take a look at the Printed Circuit Board (PCB). The components go in the side with the writing on and the solder goes on the side with the tracks and silver pads.

1 PLACE RESISTORS

Start with the three resistors:
The text on the PCB shows where R1, R2 etc go.
Ensure that you put the resistors in the right place.

PCB Ref	Value	Colour Bands
R1 & R2	470K	Yellow, purple, yellow
R3	33Ω	Orange, orange, black



2 PLACE THE TRANSISTORS

Place the two transistors into the board where it is labelled Q1 and Q2. Make sure that the device is the correct way around. The shape of the device should match the outline on the PCB.

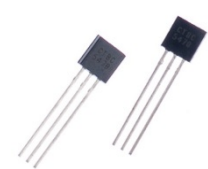

3 PLACE THE CAPACITORS

Place the two capacitors into the board where it is labelled C1 and C2. Make sure that the device is the correct way around. The capacitors have a '-' sign marked on them, which should match the same sign on the PCB. Once the legs have been pushed through the board, the capacitor should be folded flat against the PCB before it is soldered into place.

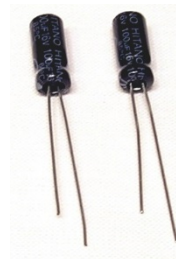

4 SOLDER THE LEDs

Place the two Light Emitting Diodes (LEDs) into LED1 and LED2. It does not matter which goes where, but the light won't work if they don't go in the right way around. If you look carefully one side of the LED has a flat edge, which must line up with the flat edge on the lines on the PCB. You may want to solder them in at a specific height depending upon how you have designed your enclosure (if you are making one). Once you are happy, solder them into place.



5 FIT THE BATTERY HOLDER

Finally, you must attach the battery holder. Start by feeding the leads through the strain relief hole near R3. The wire should be fed in from the rear of the board (see right image).

The red lead should be soldered to the '+' terminal (also marked with the text 'red') and the black lead should be soldered to the '-' terminal (also marked with the text 'black').

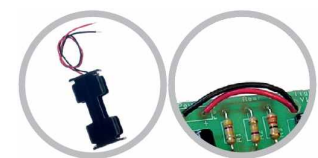

Checking Your Bike Light PCB

Carefully check the following before you insert the batteries:

Check the bottom of the board to ensure that:

- All holes (except the 4 large (3mm) holes in the corners) are filled with the lead of a component.
- All these leads are soldered.
- Pins next to each other are not soldered together.

Check the top of the board to ensure that:

- The shape of the transistors match the outline on the PCB.
- The flat edge of each of the LEDs matches the outline on the PCB.
- The '-' on the capacitors match the same marks on the PCB.
- The colour bands on R3 are orange, orange and black.
- The battery cage red and black wires match the red and black text on the PCB.

Power Up

On inserting the batteries, the LEDs should start flashing in an alternating pattern. If this does not happen, use the fault finding sheet to find the fault.



Adding an On / Off Switch

If you wish to add a power switch, don't solder both ends of the battery clip directly into the board, instead:

1

Solder one end of the battery clip to the PCB, either black to '-' or red to '+'.

2

Solder the other end of the battery clip to the on / off switch.

3

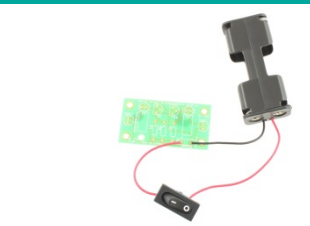
Using a piece of wire, solder the remaining terminal on the on / off switch to the remaining power connection on the PCB.



Fault finding flow chart

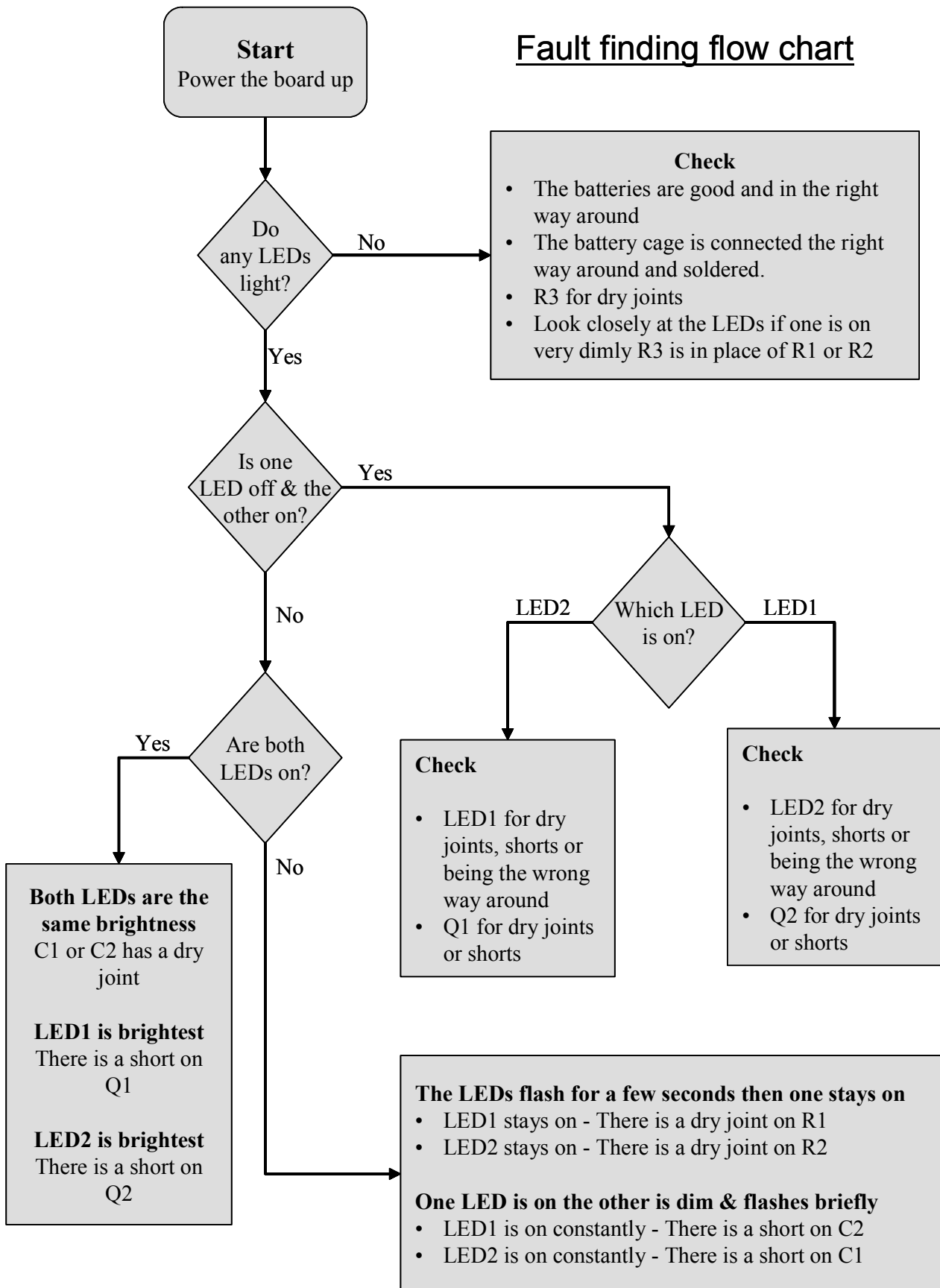

Designing the Enclosure

When you design the enclosure, you will need to consider:

- The size of the PCB (below left)
- Where the LEDs are mounted and how big they are
- Where the batteries will be housed (below right)

These technical drawings of the bike light PCB and battery holder should help you to plan this.

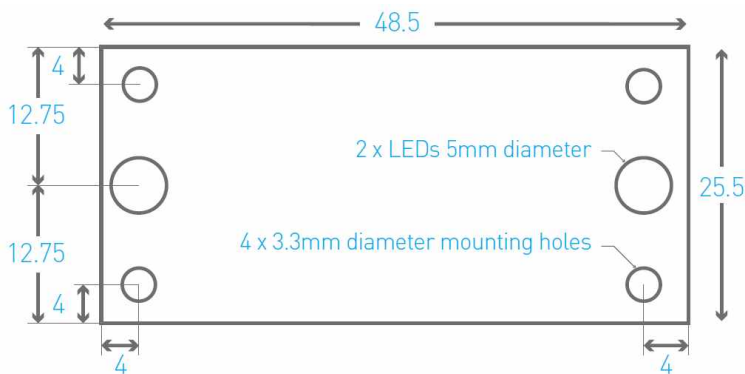

Dimensions in mm

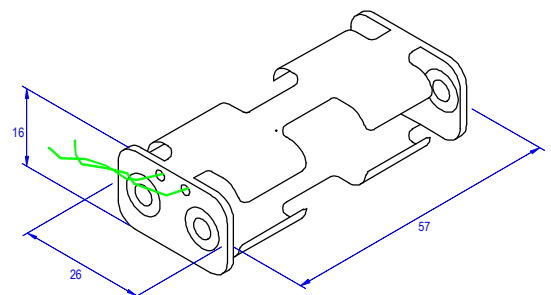

All dimensions in mm
x4 holes 3.3 mm diameter
x2 LEDs 5mm diameter

<p>The diagram illustrates the assembly process. A PCB is shown being inserted into a hex spacer, which is then placed on top of the enclosure. Two M3 bolts are used to secure the assembly. Labels include: P.C.B, SPACER, ENCLOSURE, and 2 X M3 BOLTS.</p>	<p>Mounting the PCB to the enclosure</p> <p>The drawing to the left shows how a hex spacer can be used with two bolts to fix the PCB to the enclosure.</p> <p><i>Your PCB has four mounting holes designed to take M3 bolts.</i></p>
---	---



How the Bike Light Works

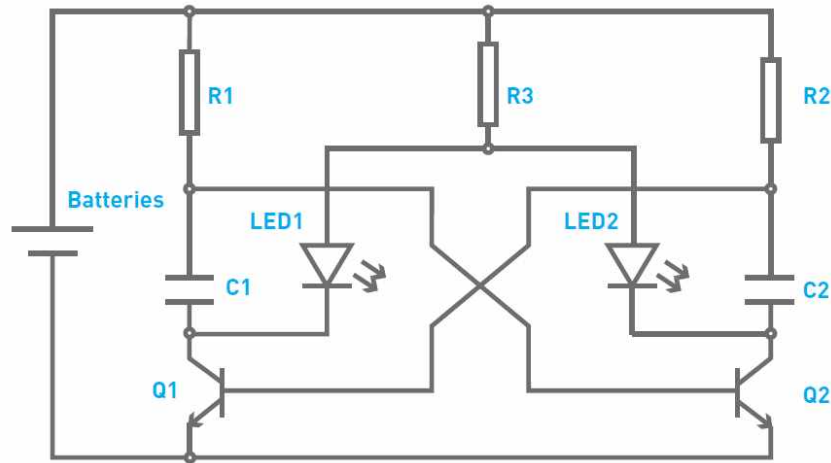

The circuit has two states which it alternates between. In each of the states one of the LEDs is on while the other is off.

State 1 (see picture right):

Q1 is turned on which connects LED1 and C1 to 0V. This turns LED1 on and C1 starts to charge through the resistor R1 causing the voltage across it to increase (it starts at less than 0.7V). The voltage at the base of Q2 starts to rise as C1 charges as they are both connected to each other.

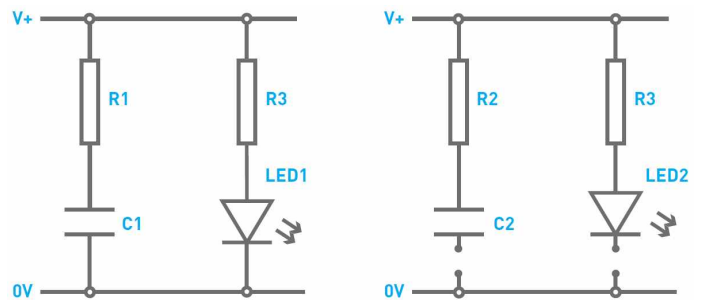

As C1 has less than 0.7V across it Q2 is turned off. This means LED2 is not connected to 0V and is therefore turned off. C2 (which has more than 0.7V across it) is gradually discharging into the base of Q1. This continues until the C1 has sufficient charge to produce a voltage $>0.7V$ on the base of Q2, which causes it to turn on.

State 2 (see picture right):

Q2 is now turned on, which connects LED2 and C2 to 0V. This turns LED2 on. This connection of C2 to 0V causes the voltage across it to drop below 0.7V, turning off Q1. Now C2 starts to charge through the resistor R2, causing the voltage across it to increase. The voltage at the base of Q1 starts to rise as C2 charges, as they are both connected to each other.

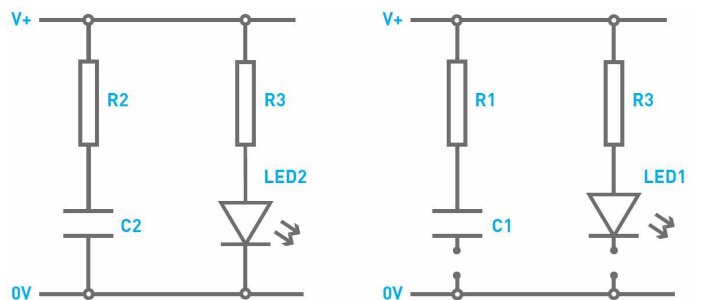

As C2 has less than 0.7V across it, Q1 is turned off. This means that LED1 is not connected to 0V and is therefore turned off. C1 (which has more than 0.7V across it) is gradually discharging into the base of Q2. The right hand side of the circuit is in the same state that the left hand side started in Stage 1, but with C2 charging instead of C1. When the charge gets high enough, the circuit flips back to Stage 1.

R3 is needed to limit the amount of current flowing through the LED. The transistors aren't fully turned on; therefore they also contribute to limiting the current flowing through the LED. This means that the current limit resistor is smaller than it would otherwise be.



Online Information

Two sets of information can be downloaded from the product page where the kit can also be reordered from. The 'Essential Information' contains all of the information that you need to get started with the kit and the 'Teaching Resources' contains more information on soldering, components used in the kit, educational schemes of work and so on and also includes the essentials. Download from:

www.kitronik.co.uk/2106



This kit is designed and manufactured in the UK by Kitronik

Telephone: +44 (0) 845 8380781

Sales email: sales@kitronik.co.uk

Tech support email: support@kitronik.co.uk

Web: www.kitronik.co.uk



www.kitronik.co.uk/twitter



www.kitronik.co.uk/facebook



www.kitronik.co.uk/youtube



www.kitronik.co.uk/google

Every effort has been made to ensure that these notes are correct, however Kitronik accept no responsibility for issues arising from errors / omissions in the notes.

© Kitronik Ltd - Any unauthorised copying / duplication of this booklet or part thereof for purposes except for use with Kitronik project kits is not allowed without Kitronik's prior consent.

