

| | | | |
|------|-----------------------|---------|------------|
| REV. | ECN NO OR DESCRIPTION | REVISED | DATE |
| A. | PDR NO.T100310-1A | JACY | 2010.07.23 |

SPECIFICATIONS:

- ELECTRICAL CHARACTERISTICS:
 - RATING:DC 19V 9A MAX.
 - CONTACT RESISTANCE:30mΩ MAX.(INITIAL)
 - DIELECTRIC WITHSTANDING VOLTAGE:500V AC FOR ONE MINUTE.
 - INSULATION RESISTANCE:100MΩ MIN. MEASURED BY 500V DC.
- MECHANICAL CHARACTERISTICS:
 - INSERTION FORCE: 0.5Kgf~3.5Kgf.
 - WITHDRAWAL FORCE: 0.5Kgf~3.5Kgf.
- LIFE TEST:5000 CYCLES MIN.
- OTHER GENERAL SPEC. TO REFER "2DC-G233 Series SPEC".
- TO CONFORM TO SINGATRON HAZARDOUS SUBSTANCE FREE SPEC.
- HALOGEN FREE PRODUCT IDENTIFICATION MARK ON JACK: Ⓞ
- HALOGEN FREE PRODUCT IDENTIFICATION LABEL ON PACKAGING: Ⓞ

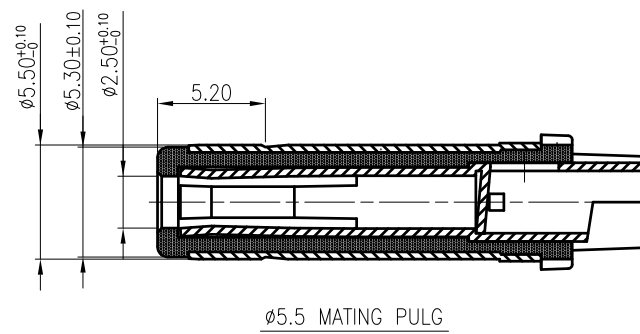
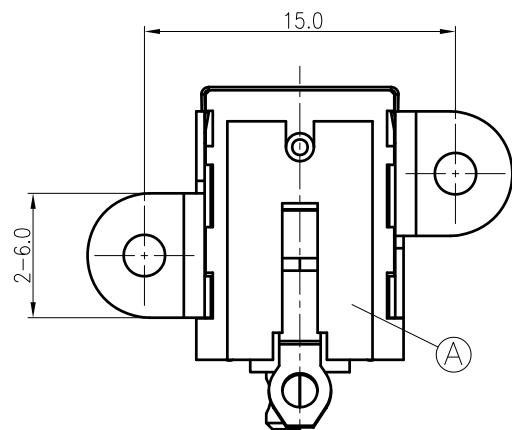
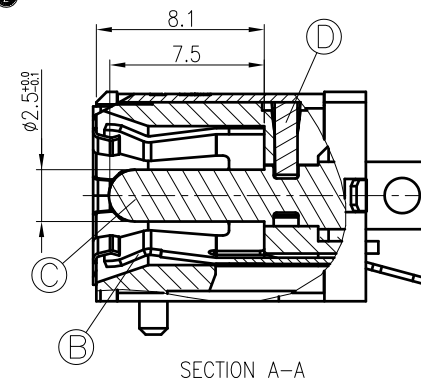
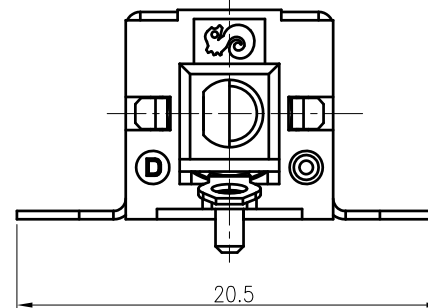
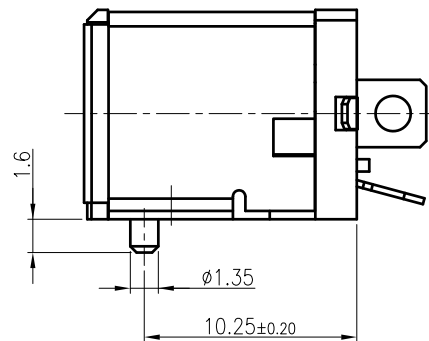
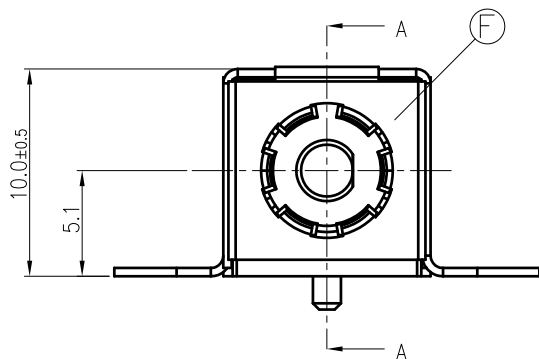
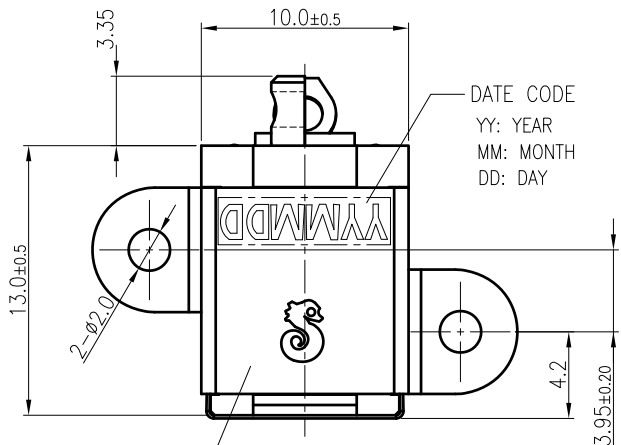
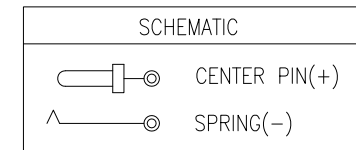

| NO | DESCRIPTION | QTY | MATERIAL | PLATING & COLOR |
|----|-------------|-----|-----------------------------------|----------------------------|
| F | GROUND | 1 | STAINLESS 0.15T | N/A |
| E | SHELL | 1 | SPCC-SD 0.4T | Ni60u"Min. Over Cu80u" |
| D | STOPPER | 1 | HIGH TEMP. THERMOPLASTIC ,UL94V-0 | BLACK |
| C | PIN | 1 | BRASS BAR | Gold Flash Over Ni 50u"Min |
| B | SPRING | 1 | COPPER ALLOY 0.3T | Ag 20u"Min Over Ni 50u"Min |
| A | BODY | 1 | HIGH TEMP. THERMOPLASTIC ,UL94V-0 | BLACK |

UNLESS OTHERWISE SPECIFIED TOLERANCES

DECIMALS: ANGLES:
 X :±0.5 X :±2°
 X.X :±0.3 X.X :±1°
 X.XX :±0.2

Singatron Enterprise Co., Ltd.
 信音企業股份有限公司

TITLE: DC POWER JACK(For NEC)
 DWN: PART NO. 2DC-G233-B37
 CHKD: SCALE 4:1 UNIT: mm
 APVD: SIZE: A3 SHEET:1 OF 1 REV: A

CUSTOMER COPY