

| REV. | DESCRIPTION                                   | DATE     | APPROVED |
|------|---|----------|----------|
| F    | Updated Material.                             | 10/28/08 | T. Y.    |
| G    | Added Ordering Information.                   | 06/06/11 | T. Y.    |
| H    | Removed Part Numbers from Part Offering List. | 05/06/15 | J. C.    |
| J    | Updated Material Description.                 | 10/09/15 | J. C.    |
| K    | Engineering Update w/o Changes.               | 10/22/15 | J. C.    |

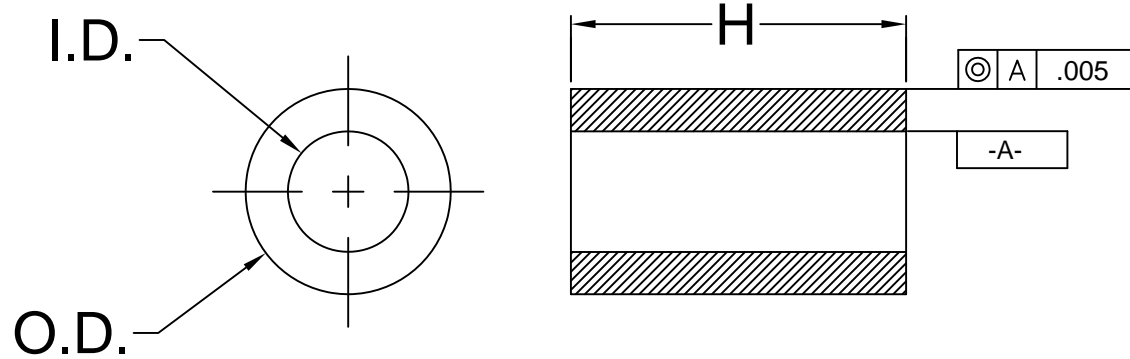

| SERIES | "H" DIMENSION         | I.D.       | O.D.       |
|--------|-----------------------|------------|------------|
| 901    | .030-1.250 (.76-31.8) | .028 (.71) | .085 (2.2) |
| 902    | .030-1.250 (.76-31.8) | .032 (.81) | .125 (3.2) |
| 903    | .030-1.250 (.76-31.8) | .047 (1.2) | .156 (4.0) |
| 904    | .030-1.250 (.76-31.8) | .063 (1.6) | .187 (4.7) |
| 905    | .030-1.250 (.76-31.8) | .147 (3.7) | .250 (6.4) |
| 906    | .030-1.250 (.76-31.8) | .085 (2.2) | .148 (3.8) |
| 907    | .030-1.250 (.76-31.8) | .105 (2.7) | .167 (4.2) |
| 908    | .030-1.250 (.76-31.8) | .125 (3.2) | .187 (4.7) |
| 911    | .030-1.250 (.76-31.8) | .125 (3.2) | .250 (6.4) |
| 912    | .030-1.250 (.76-31.8) | .171 (4.3) | .250 (6.4) |
| 913    | .030-1.250 (.76-31.8) | .091 (2.3) | .187 (4.7) |
| 937    | .030-1.250 (.76-31.8) | .090 (2.3) | .125 (3.2) |
| 938    | .030-1.250 (.76-31.8) | .032 (.81) | .085 (2.2) |
| 939    | .030-1.250 (.76-31.8) | .047 (1.2) | .125 (3.2) |
| 940    | .030-1.250 (.76-31.8) | .063 (1.6) | .156 (4.0) |

ORDERING INFORMATION:

**9XX-XXX**

SERIES — LENGTH  
 INCHES, MULTIPLES OF .005"  
 .030" = 030  
 .100" = 100  
 1.250" = 1.250

WHOLE MILLIMETERS  
 2mm = 2MM  
 5mm = 5MM

3. TOLERANCE "H" DIMENSION:

0.030 - 0.500 (1.0 - 12.7mm)±0.005(0.1mm)  
 0.505 - 0.750 (12.8 - 19.1mm)±0.008(0.2mm)  
 0.755 - 1.250 (19.2 - 31.8mm)±0.015(0.4mm)

2. MATERIAL: NYLON 6, ULTRAMID 8270 HS, NATURAL. BIVAR MATERIAL CODE 01-NL-WE.  
 ALLIED CHEMICAL POLYAMID NYLON 6 WITH CLARIANT CNY02655 WHITE NYLON CONCENTRATE.

1. GENERAL SPECIFICATIONS: BIVAR EXTRUDED PRODUCT SPECIFICATION BV00-E103.

|  |                          |  |                          |                            |                       |
|--|--------------------------|--|--------------------------|----------------------------|-----------------------|
| STANDARD TOLERANCE<br>(UNLESS OTHERWISE SPECIFIED) |                          | <br>4 THOMAS, IRVINE, CA. 92618<br>TEL: (949) 951-8808 FAX: (949) 951-3974 |                          |                            |                       |
| DECIMALS   | ANGULAR                  |  |                          |                            |                       |
| .X ±.1   | X° ±1°                   | <br><b>TITLE:</b><br>NYLON TUBE SPACERS                                    |                          |                            |                       |
| .XX ±.01   |                          |  |                          |                            |                       |
| .XXX ±.005   |                          | DESIGNED:<br><b>Michael Chen</b>   | DATE:<br><b>01/13/03</b> | <b>PART NO:</b><br>9XX-XXX | REVISION:<br><b>K</b> |
| CHECKED:<br><b>D. Green</b>                        | DATE:<br><b>01/13/03</b> | <b>CAGE CODE : 32559</b>   |                          |                            | <b>SHEET # 1 OF 1</b> |
| CAD GENERATED DOCUMENT. DO NOT MEASURE DRAWING.    |                          |  |                          |                            |                       |