



产品规格书

Specifications

版本号/ Version number: A/0

MERCURY INDUSTRY CO LIMITED

气泵规格书

Specification of air pump

客 户: _____

Customer

品 名: **DC VACUUM PUMP**

Part name

型 号: AP030-060

Model

日 期: **2022-10-28**

Date

页 数: 共 7 页 (包括封面)

Number of pages: 7

作 成	审 核	核 准

客户承认

Customer acknowledgment

--	--	--	--

ADD: 11Bldg, 3# Pingan Ave, Longgang, Shenzhen, 518111, China



产品规格书

Specifications

版本号/ Version number: A/0

1. 适用范围 Application:

本规格书适用 AP030 气泵之用.

The specifications apply AP030 use.

2. 测试环境 Standard test environment:

2-1	测试环境温度 Environment test	周围温度 20℃ 相对湿度 65%RH 为标准, 如无争议发生可以在下述环境测试: 周围温度 5-45℃ 相对湿度 30-80%RH. The standard of environment test is the ambient temperature of 20℃ and relative humidity of 65%RH. If no disputes occur, the test can be conducted under the blow circumstance: the ambient temperature of 5~45℃ and relative humidity of 30~80%RH.
2-2	测试姿势 (Position)	水平 (Horizontal)
2-3	负荷 (Load)	空气 (air)
2-4	使用温度范围 Operation temperature range	5 ~45° C(Humidity to 30% to 80%RH)
2-5	保存温度范围 Preservation temperature range	-20 ~60° C(Humidity to 30% to 80%RH)

3 电气特性 Electrical characteristics:

3-1	额定电压 Rated voltage	DC6V	
3-2	使用电压范围 Operating voltage range:	DC5.8~6.8V	
3-3	负载电流 no-load current	在 DC6V 时, 气泵空载抽气时的最高空载电流 $\leq 400 \text{ mA}$ At DC6V ,The highest current is less than 300mA while the pump no load.	$\cong 400 \text{ mA}$ Less than 400mA
3-4	空载流量 Air Flow	在 DC6V,空载流量大于或等于 0.8 升/分钟. More than 0.8L/min. At DC6V ,the air flow is more than 0.8 L/min with no load..	$\geq 0.8 \text{ L/min}$ More than 0.8L/min.
3-5	噪音 Noise	下垫 5cm 之海绵, 距噪音计 30cm 之处, 依 DC 6V 之电源冲气压力从 0 到 200mmHg 所测得之 dB 值小于 65dB.	$< 65 \text{ dB}$ Less than 65dB

ADD: 11Bldg, 3# Pingan Ave, Longgang, Shenzhen, 518111, China



产品规格书

Specifications

版本号/ Version number: A/0

		Putting a 5 cm sponge under the pump, and placing it about 30 cm away from the noise meter, The evaluated noise level shall be less than 65dB while pressurizing with DC7V from 0 to 200mmHg.	
3-6	最大真空度 Maximum vacuum	输入 6V 之电压吸气压力从 0 到停止减压之最高真空值大于 -50KPa. The maximum vacuum value shall be more than -50KPa while pressurizing with DC 7V tank from 0 till dead-head vacuum value.	≥-50kpa More than -50kpa

4 环境试验 Environmental Tests:

4-1	低温放置试验 Low-temperature characteristic	放置在 -20℃ 经 72 小时后, 再取出置于常温(20±5℃)中 2 小时依下列专案测试无异状 3-3, 3-4, 3-5, 3-6. Putting the pump in the temperature at negative 20 °C for 72 hours; then taking it out and putting it in a room temperature at 20 ± 5 °C for 2 hours, Under this circumstance, running through test 3-3, 3-4, 3-5, 3-6 and finding out that the pump still performs well.
4-2	高温放置试验 High-temperature characteristic	在 60℃ 经 72 小时放置后, 在放常温(20±5℃)中 2 小时依下列专案测试无异状 3-3, 3-4, 3-5, 3-6. Putting the pump in the temperature at 60 °C for 72 hours; then taking it out and putting it in a room temperature at 20 ± 5 °C for 2 hours, Under this circumstance, running through test 3-2, 3-3, 3-4, 3-5, 3-6. and finding out that the pump still performs well.
4-3	高温高湿放置试验 High-temperature & High humidity	在温度 60℃, 湿度 95% 环境中经 72 小时取出置于常温(20±5℃)中 2 小时依下列专案测试无异状 3-3, 3-4, 3-5, 3-6. Putting the pump in the temperature at 60 °C and the humidity at 95% for 72 hours; then taking it out and putting it in a room temperature at 20 ± 5 °C for 2 hours. Under this circumstance, running through test 3-3, 3-4, 3-5, 3-6. and finding out that the pump still performs well.
4-4	温湿度循环放置测试 Temperature & humidity cycle	在经过 12 次的温湿度循环测试后: -20℃ * 2Hr → +25℃ * 1Hr → +60℃ 85%RH * 2Hr → +25℃ * 1Hr, 需维持相同的性能. 依下列

ADD: 11Bldg, 3# Pingan Ave, Longgang, Shenzhen, 518111, China



产品规格书

Specifications

版本号/ Version number: A/0

	test	专案测试无异状 3-3, 3-4, 3-5, 3-6.After doing the temperature and humidity cycle test,-20℃ * 2Hr → +25℃ * 1Hr→+60℃ 85%RH* 2Hr →+25℃ *1Hr,for twelve times,the pump shall still perform the same functions proved by running through test 3-3, 3-4, 3-5, 3-6.
4-5	寿命试验 Life test	<p>在 200CC 容器中,抽气 10 秒,停 2 秒为一个循环,测试 20,000 次以后经下列专案测试无异状 3-3, 3-4, 3-5, 3-6.</p> <p>Ia a 200CC tank,pressurizing for 10 seconds,exhaust for 2 seconds is as one cycle,Doing it for 20000 times, then examine the pump by test 3-3, 3-4, 3-5, 3-6.and figure out than the pump is still in a good function.</p>

5 特殊环境测试 Thermal test performance:

在经过发下 5-1 和 5-2 项目之特殊环境测试后, 要产品须可满足项目 3-3 至 3-6 之基本性能。

After the pump has been tested through test 5-1 and 5-2, it must be suitable the basic performance required by item 3-3 to 3-6.

5-1	低温环境测试 Low-temperature environment test	<p>在温度 0℃ 经五小时后, 立即在此温度下依下列专案测试无异状, 3-3, 3-4, 3-5, 3-6.</p> <p>Under a temperature of 0℃ for 5 hours, then examining the pump by test 3-3, 3-4, 3-5, 3-6. and finding out it still perform well.</p>
5-2	高温环境测试 High-temperature environment test	<p>在温度 50℃ 经五小时后, 立即在此温度下依下列专案测试无异状, 3-3, 3-4, 3-5, 3-6.</p> <p>Under a temperature of 50℃ for 5 hours, then examining the pump by test 3-3, 3-4, 3-5, 3-6. and finding out it still perform well.</p>

6 其它 Others:

6-1	端子强度 The lead tension	<p>以 0.5 公斤法码与端子平行负载无异常者.</p> <p>Hanging a 0.5 Kg static load on the terminal of the pump will not cause a damage on the pump.</p>
6-2	落下实验 Fall test	<p>使用标准的包装方式,在水泥地上将其从 50cm 的高度分别从正面,侧面,及边角落下,其性能及结构需无异常.</p> <p>Basic performance and the struture shall not be defected after following test;With a standard packaging conditions,then dropping it at the front,side,and edges part from the height of 50 cm to the concrete floor.</p>

ADD: 11Bldg, 3# Pingan Ave, Longgang, Shenzhen, 518111, China



产品规格书

Specifications

版本号/ Version number: A/0

6-3	外观 Appearance	产品无不适当的外观和刮伤, 脏污...等. The appearances of the pump shall not contain cracks and impurities.
6-4	异常试验 Unusual test	以 DC7V 堵住出气口, 全负载连续 2 分钟通电无燃烧,发烟现象. There is no burning and smoking occurrence while the power is on with DC 7V for 2 minute continuously.
6-5	焊锡要求 Solder requirements	马达端子焊锡作业需在焊锡温度 380°C 下,3 秒内操作完成. Motor terminal for Soldering process the heat temp. is controlled by 380°C, and operating time is for 3 sec only.
6-6	马达转速 Motor speed	马达空载转速 8200±10%rpm

7 噪音测试线路图 Noise test circuit diagram:

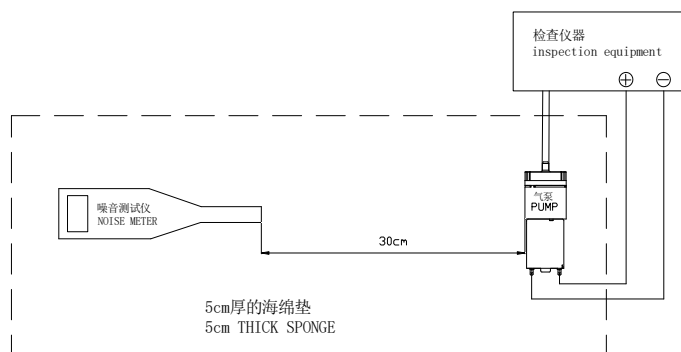

8 材料表 Material list:

ADD: 11Bldg, 3# Pingan Ave, Longgang, Shenzhen, 518111, China



产品规格书

Specifications

版本号/ Version number: A/0

1	塑胶 B1	PLASTIC	
2	塑胶 B2	PLASTIC	
3	塑胶 B3	PLASTIC	POK
4	塑胶 B4	PLASTIC	POK
5	塑胶 B5	PLASTIC	POK
6	塑胶 B6	PLASTIC	
7	钢针	STEEL	
8	螺丝	SUS1006	
9	橡胶	RUBBER	
10	马达	DC7V	

9.成品外形图 Finished Outline

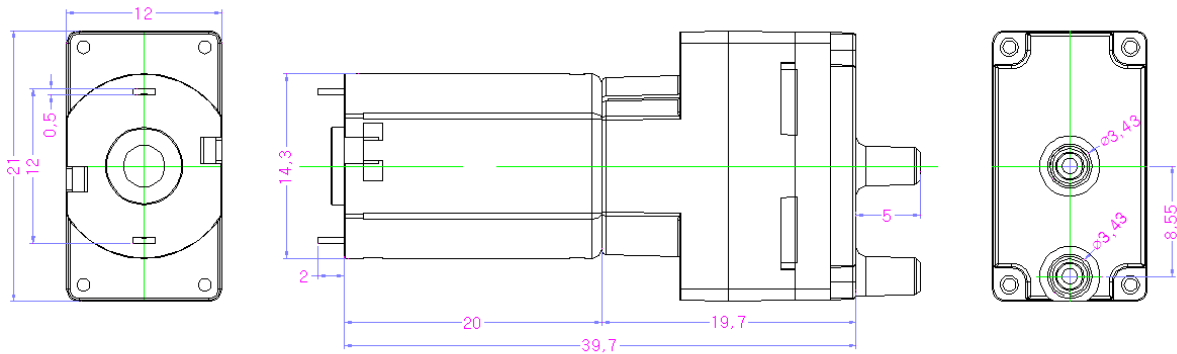

注：马达上 XXXXXX 为日期码 型号按送样实际雕刻。

10.包装图 Packagin

ADD: 11Bldg, 3# Pingan Ave, Longgang, Shenzhen, 518111, China



产品规格书

Specifications

版本号/ Version number: A/0

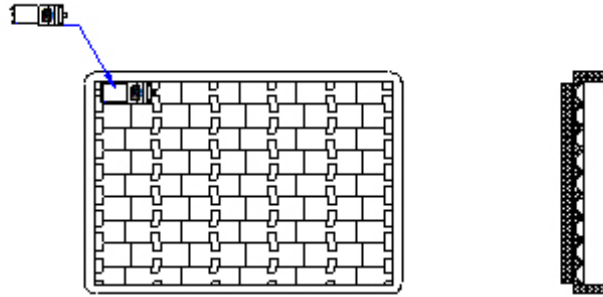

每盒50PCS
50PCS/box

50pcs/盒

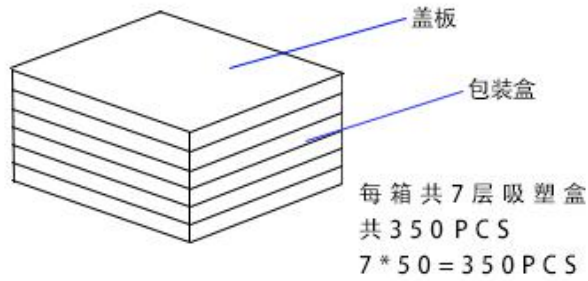

50pcs*7 盒=350pcs/箱

ADD: 11Bldg, 3# Pingan Ave, Longgang, Shenzhen, 518111, China