

Digital Intelligent PIR Sensor BM-612

General Description

The product is a type of intelligent PIR sensor which integrates digital circuit and sensitive element in a hermetically sealed package. It interfaces directly with up two conventional PIR sensors via a high impedance differential input. The PIR signal is converted to a digital value on chip. A REL output indicates whenever the PIR Signal is above the selected threshold. The OEN can control the REL output or through the light sensor. The parameters for sensitivity and timing are set by connecting the corresponding inputs to DC voltages. All signal processing is performed digitally.

Features

- Digital signal processing, no drift and aging
- High power supply rejection ratio, anti-radio frequency interference (mobile phone, WiFi, etc.)
- A second-order Butterworth bandpass filter with built-in infrared sensor to shield input interference at other frequencies
- Sensitivity, Ontime, and light sensor Schmitt REL output.
- Ontime adjustable
- Good stability and effective suppression of repeated malfunctions
- Low power consumption and simple application circuit



Applications

Consumer electronics applications:

- Toy
- Digital photo frame, Doorbell
- TV, refrigerator, Air conditioner

Smart home, security applications:

- USB alarm
- Intrusion detection
- Network camera
- LAN monitor
- Private alarm
- Car alarm system

Lighting application:

- Automatic lighting of indoors, courtyards, corridors, staircase lights, etc.

Product Type Series

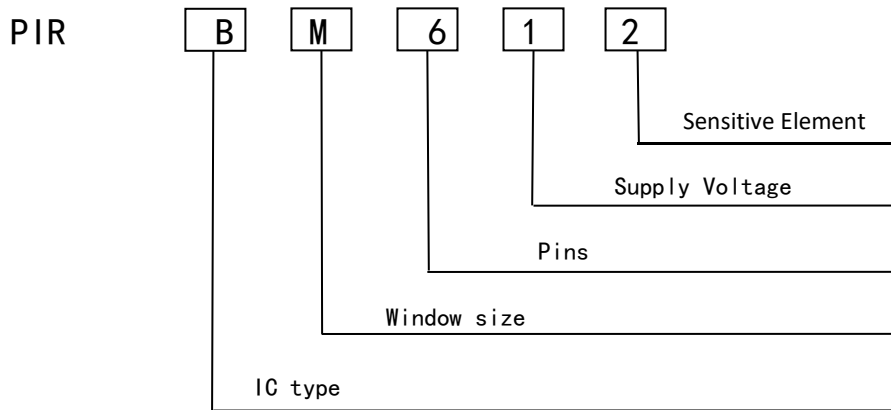

Technical data

1. Absolute Maximum Ratings

Electrical characteristics(beyond those listed below may cause permanent damage to the device. Exposure to absolute maximum ratings may affect the device reliability.)

Parameter	Symbol	Min	Max	Unit	Remarks
Operating Temp	T _{ST}	-30	70	°C	
Current into any pin	I _{into}	-100	100	mA	
Storage Temp	T _{ST}	-40	80	°C	

2. Operating Conditions (T=25°C, V_{DD}=3V, unless stated otherwise)

Parameter	Symbol	Min	Type	Max	Unit	Remarks
Regular voltage	V _{DD}	2.2	3	3.7	V	
Supply current	I _{DD}	9	9.5	11	μA	
Sensitivity threshold	V _{SENS}	90		2000	μV	
Detective Wavelength	λ	5		14	um	
Outputs REL						
Output current low	I _{OL}	10			mA	V _{OL} <1V
Output current high	I _{OH}	-10			mA	V _{OH} >(V _{DD} -1V)
Low REL output locking time	T _{OL}		2		s	Non-adjustable
High REL output delay time	T _{OH}	2		3600	s	
Inputs SENS, ONTIME						
Input voltage range		0		V _{DD} /2	V	Adjustable between 0V and V _{DD} /2
Input leakage current		-1		1	μA	
Input OEN						
Input low voltage	V _{IL}	0.8V-1.2V (Hysteresis zone)		0.8	V	Voltage threshold from high to low
Input high voltage	V _{IH}	1.2			V	Voltage threshold from low to high
Input current	I _I	-1		1	μA	V _{SS} <V _{IN} <V _{DD}
Oscillator and Filter						

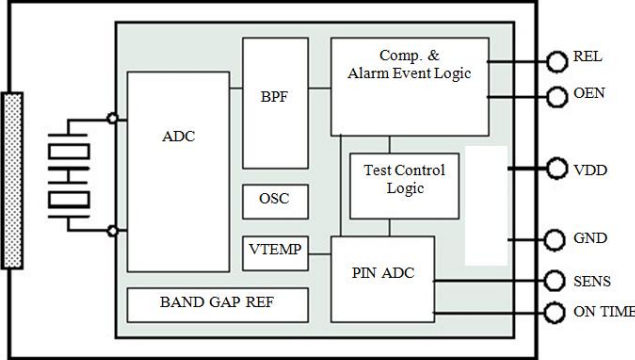
LPF cutoff frequency			7	Hz	
HPF cutoff frequency			0.44	Hz	
On chip oscillator frequency	F _{CLK}		64	kHz	
Interior diagram					

3. Alarm Event Processor

When the PIR signal level exceeds the set sensitivity threshold an internal pulse is generated. A second pulse is counted, when the signals changes sign and exceeds the threshold again. Whenever 2 pulses appear within 4s, the PIR signal detection will give an alarm signal and the REL output is activated.

Large signals in excess of $5 \times$ the selected threshold result in immediate activation of the relay output. The following is the trigger logical diagram. For multiple times activate, the REL output duration is counted from the last effective pulse.

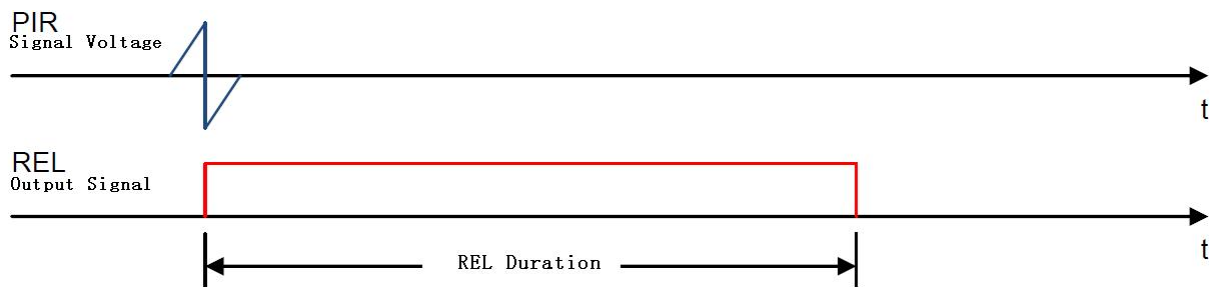

The duration of REL output in single activation

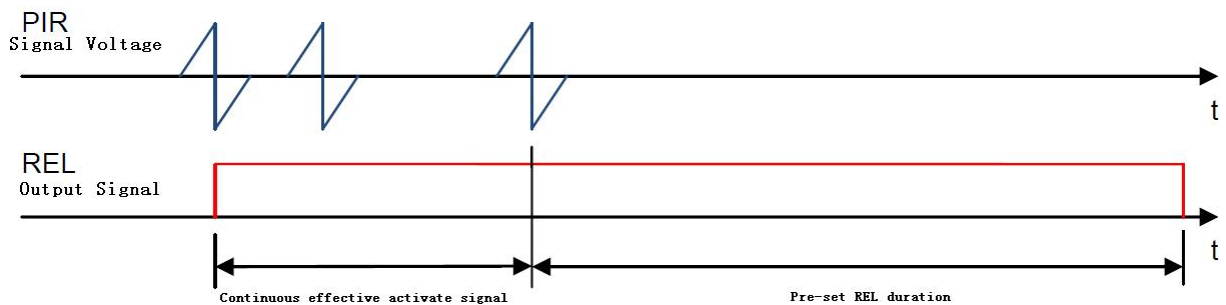

The intelligent PIR sensor alarm event diagram

4. ONTIME

When the motion signal is detected, there will be a REL output. A voltage applied to the ONTIME input set the time the REL output is active with a single trigger event. Any REL output signal will reset the REL ONTIME, and re-timing again.

4.1

In analog REL mode, connect ONTIME Pin to voltage with a resistance which could adjust in 100 KΩ—510 KΩ. In analog mode, the ONTIME pin will have a corresponding oscillation frequency, the analog time delay $T_d = \frac{230400}{f}$, f is the oscillation frequency. For more time delay, the ONTIME Pin can connect one more capacity GND except resistance. Capacitor should be selected according to different requirements, but the capacitance value $\leq 10\text{nF}$, and the resistance value between 100K to 510KΩ.

The operating current is inversely proportional to the selected resistance R . The larger the resistance value, the smaller the operating current. If the power consumption requirement is high, it is recommended to use a larger resistor (300K-510K) or a digital REL timing mode. To obtain accurate timing time, select the appropriate capacitor resistance value, first calculate the timing time according to the oscillation frequency, and then adjust the capacitor resistance parameter.

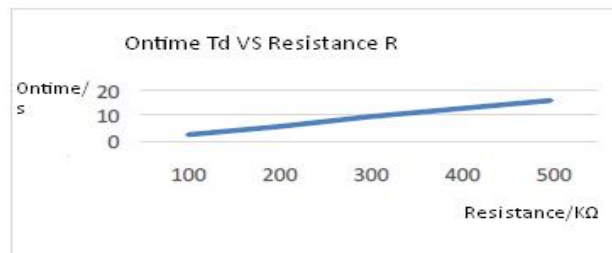

Diagram 1 ONTMIE Pin without Capacity

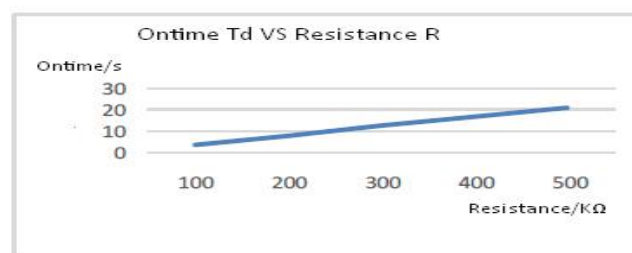

Diagram 2 ONTMIE Pin with 10pF Capacity

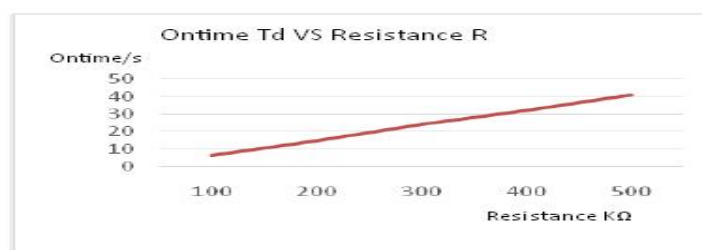

Diagram 3 ONTMIE Pin with 560pF Capacity GND

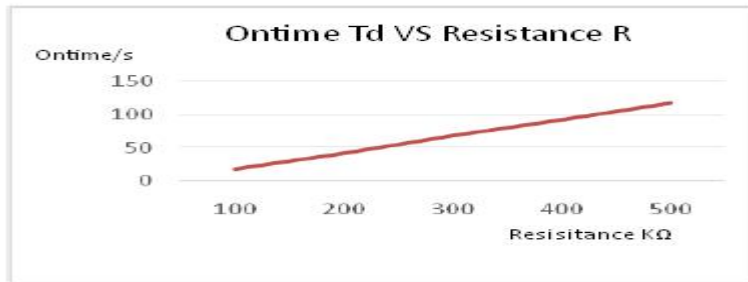

Diagram 4 ONTMIE Pin with 1nF Capacity GND

4.2

In digital REL mode, ONTIME Pin connect with a fixed potential less than $VDD/2$ (in application, the REL can adjust by adopting resistance divider). The REL output retention time is set by input voltage of ONTIME through the only trigger. Set the resistance-high $1M\ \Omega$, the resistance-low as the table below. The output time delay (Time Td) and voltage preferences refer to the diagram below. Notice: In digital REL mode, the ONTIME voltage couldn't over $VDD/2$, and ONTIME must select from the 16 types in following diagram, or the analog REL mode is recommended.

No.	Time Td (s)	ONTIME Voltage Range (VDD)	ONTIME Voltage Central Value (VDD)	Recommend Divider Resistance ($\pm 0.1\%$)	
				resistance-high	resistance-low
1	2	0~1/32 VDD	1/64 VDD	1M	0R
2	5	1/32~2/32 VDD	3/64 VDD	1M	51K
3	10	2/32~3/32 VDD	5/64 VDD	1M	82K
4	15	3/32~4/32 VDD	7/64 VDD	1M	120K
5	20	4/32~5/32 VDD	9/64 VDD	1M	160K
6	30	5/32~6/32 VDD	11/64 VDD	1M	200K
7	45	6/32~7/32 VDD	13/64 VDD	1M	240K
8	60	7/32~8/32 VDD	15/64 VDD	1M	300K
9	90	8/32~9/32 VDD	17/64 VDD	1M	360K
10	120	9/32~10/32 VDD	19/64 VDD	1M	430K
11	180	10/32~11/32 VDD	21/64 VDD	1M	470K
12	300	11/32~12/32 VDD	23/64 VDD	1M	560K
13	600	12/32~13/32 VDD	25/64 VDD	1M	620K
14	900	13/32~14/32 VDD	27/64 VDD	1M	750K
15	1800	14/32~15/32 VDD	29/64 VDD	1M	820K
16	3600	15/32~16/32 VDD	31/64 VDD	1M	910K

5. Sensitivity

A voltage applied to the SENS input sets the threshold used to detect a PIR signal between the PIRIN and NPIRIN inputs. VSS selects the minimum threshold voltage. When the SENS pin grounded, the threshold voltage is least and the PIR signal detection sensitivity is highest. Any voltage above $VDD/2$ will select the maximum threshold which is the least sensitive setting for PIR signal detection. It should be noted that the detective distance of PIR sensor and SENS input

voltage is not linear relationship. In fact, the distance is affected by its own SNR, imaging distance of Fresnel lens, temperature of the moving body, environment temperature and humidity, and electromagnetic interference, etc. So the output cannot evaluate by single index, please take the adjustment result as the standard in practical application. When the SENS Pin voltage smaller, the detective distance get longer. The sensor have 32 levels detection distance for choose, the shortest distance reaches centimeter level. In practical application, SENS is adjusted by divider resistance.

Number	SENS Pin Voltage		Number	SENS Pin Voltage	
	Voltage Range (VDD)	Center Voltage (VDD)		Voltage Range (VDD)	Center Voltage (VDD)
0	0~1/64	1/128	16	16/64~17/64	33/128
1	1/64~2/64	3/128	17	17/64~18/64	35/128
2	2/64~3/64	5/128	18	18/64~19/64	37/128
3	3/64~4/64	7/128	19	19/64~20/64	39/128
4	4/64~5/64	9/128	20	20/64~21/64	41/128
5	5/64~6/64	11/128	21	21/64~22/64	43/128
6	6/64~7/64	13/128	22	22/64~23/64	45/128
7	7/64~8/64	15/128	23	23/64~24/64	47/128
8	8/64~9/64	17/128	24	24/64~25/64	49/128
9	9/64~10/64	19/128	25	25/64~26/64	51/128
10	10/64~11/64	21/128	26	26/64~27/64	53/128
11	11/64~12/64	23/128	27	27/64~28/64	55/128
12	12/64~13/64	25/128	28	28/64~29/64	57/128
13	13/64~14/64	27/128	29	29/64~30/64	59/128
14	14/64~15/64	29/128	30	30/64~31/64	61/128
15	15/64~16/64	31/128	31	31/64~32/64	63/128

Application Circuit

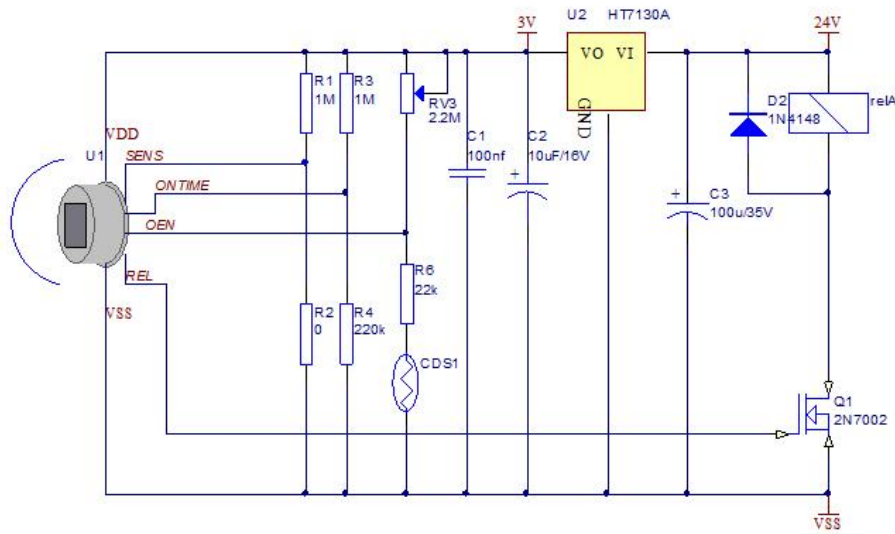

Dimensions

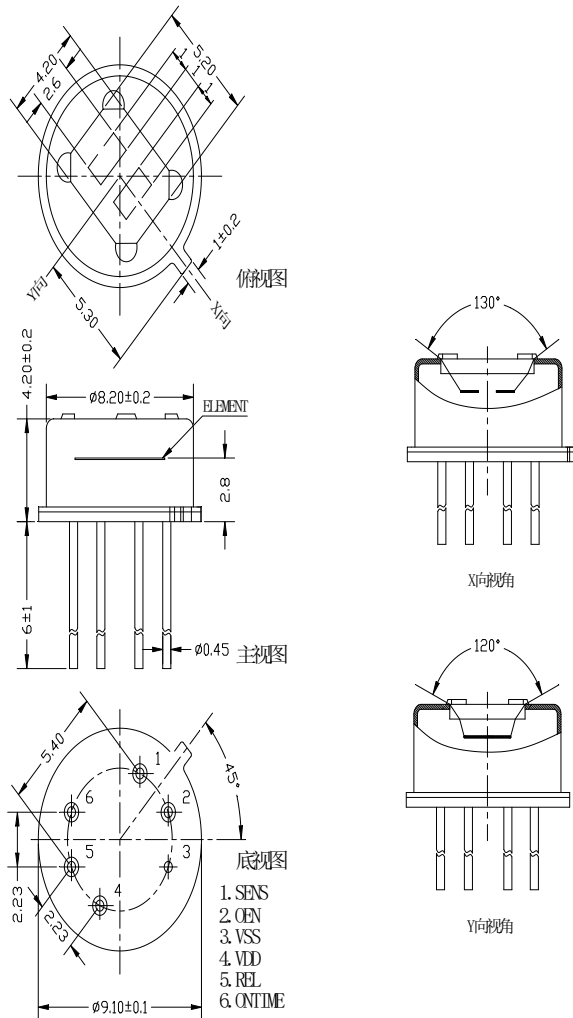

Sensor External View (UNIT: mm)

 Reliable Test

No.	Test item	Test condition	Test equipment	Remarks
1	Moisture resistance	Temperature 35 °C, relative humidity 95% RH, for 500H	Temp&Humi Chamber	After testing, the sensor placed 3H in the natural environment. then test the electrical performance. Standard: 1.No obvious change in appearance. 2.The electrical parameter changes within 15%.
2	Low temperature storage	Temperature -40 °C, for 500H	Temp&Humi Chamber	
3	High temperature storage	Temperature 80 °C, time 500H	Temp&Humi Chamber	
4	High and low temperature impact	-40 °C, 1H / room temperature, 1H / 40 °C, 1H for 10 cycles	Thermal shock test chamber	
5	Solder resistance	Temperature 260±5 °C, 10S immersion depth 3MM	Tin stove	
6	vibration	Frequency 10-55Hz, vibration time 2H at 3 axis direction	Vibration test bench	
7	seal	Pressure 0.1MPa for 1Min	Vacuum tester	

Caution

Circuit design

1. The connection between PIR Sensor and other devices should be as short as possible. On the multi-panel or multi-layer board, try not to trace the line below the connection, especially no large current.

2. The circuit of the PIR human sensing part should be made in one single PCB board to avoid interference. If done on the same board, the PIR body sensing part of the circuit should be isolated and have a separate ground; only connect the other circuits through the positive, negative and output three lines.

3. VDD of the PIR Sensor should connect to ground with 100NF capacitor as close as possible.

Soldering Requirement

Soldering requirements

Manual soldering requirements

1. For manual soldering, soldering must be completed within 3 seconds and the soldering iron temperature is below 350°C。

Reflow soldering:

1. The wave soldering temperature is set at $260 \pm 5^{\circ}\text{C}$ and the speed $1500 \pm 300\text{mm}/\text{min}$.

2. The furnace temperature should not exceed 260°C , and the time should not exceed 3S.

(Note: The induction performance will be degraded or the function will be invalid by high temperature.)

3. During wave soldering, the PIR should not be tightly close to the PCB. It is recommended that 1mm or more distance, to prevent short-circuited.

4. Wipe the widow with dry cloth or absolute ethanol if there is stain.

Application

1. The PIR sensor detect changes of infrared ray. The sensor can only detect the heat source which is changing or moving from human body. The following items should be noticed. Please confirm the performance and reliability by practical application.

1.1 When detect the heat source besides human body

(1)Pet get into detection area.

(2)In a place exposed directly to sunlight or headlight of automobile.

(3)In a place exposed directly to blow from air-conditioner or heater which make drastic change of temperature in detection area.

1.2 The heat source is hardly detected

(1)In such a place where infrared ray is shaded by glass, propenyl, etc.

(2)The heat source does not move or high-speed move in the detection area.

2. The detection area extended

Even outside the designated detection area, there also exists broad detection area when there is a large temperature difference(above 20°C) between environment and human body.

3. Other usage

3.1 Optical filter of sensor should not be soiled because it may cause failure or malfunction.

3.2 The lens is made by polyethylene. Please avoid stress or impact on the lens, or it will cause performance reduction and work unusually.

3.3 Electronics (above ± 200) should be avoided. Please do not touch terminal by hand.

3.4 Please avoid cleaning the sensor. The cleaning fluid may cause malfunction.

3.5 In order to avoid the interference effect of wires, the shielded wire is recommended and tries to make it short.

3.6 Each Fresnel lens has a fixed focal length. Be careful to adjust its focal length when installing, or the sensitivity will be reduced.

3.7 Be sure the Fresnel lens and the finished casing installed then to test. The sensor's iron shell and pins cannot be exposed.