

承 认 书

SPECIFICATION FOR APPROVAL



This is a preliminary specification intended for design purposes and subject to change without prior notice.

Commodity:

- ❖ Outline (L×W×H) : 1.6mm×0.8mm×0.6mm
- ❖ Forward current: 0.5mA ≦ I_F ≦ 30mA
- ❖ Typical viewing angle 50% I_v: 140°
- ❖ RoHS/HF and REACH-compliant
- ❖ Lens color: water transparent
- ❖ Good thermal dissipation & optical uniformity
- ❖ Qualified according to JEDEC MSL : Level 3

➢ PLEASE PAY ATTENTION TO THE MOISTURE-ABSORBING PROBLEM, AND REFER TO THE OPERATING INSTRUCTIONS FOR THE DETAILS

客户名称/型号 Customer Name/ No		
产品型号 Model No	H1608AV22A0C11	
样品编号 Sample No		
客户确认 Check By	客户核准并签章 Authorized By	客户产品要求范围 Application Range

❖ 承认盖章后请寄回承认书一份。自客户下单 1 个月以内未签回且无任何反馈，视为默认承认
Please return a document after admitted. After the order, it is regarded as the default if the customer has not signed back and not any feedback within 1 month.

Approved By: 陆北树

Checked By: 冯志

Prepared By: 姚丹

Table of Contents

❖ Product Code Method	03
❖ Maximum Rating.....	03
❖ Typical Product Characteristics	04
❖ Range of Bins	04
❖ Electronic-optical Characteristics	05
❖ Dimensions.....	06
❖ Reflow Profile.....	07
❖ Test Circuit and Handling Precautions.....	08
❖ Packing	09-10
❖ Precautions	11
❖ Test Items and Results of Reliability	12

Specification version update resume

Version	Update content	Update time	Remarks
V1	首次发行	2019-09-09	姚丹

❖ Product Code Method

$$\frac{H}{1} - \frac{1608}{2} - \frac{A}{3} - \frac{V22A}{4} - \frac{0}{5} - \frac{C}{6} - \frac{11}{7}$$

1、The Company Initials	2、Lead Frame	3、Light Code	4、Dice Wavelength & Luminous Rank
H : Hongbright	1608 (L×W) : 1.6mm×0.8mm	A : Top light	V22A : Red

5、Lap Polarity	6、Zener Code	7、Material Flow Code
0 : Non-common cathode and non-common anode	C: Without Zener	Material Flow Code

❖ Maximum Rating (Ta=25°C)

Characteristics	Symbol	Rating	Unit
DC Forward Current	I _F	30	mA
Pulse Forward Current*1	I _{FP}	100	mA
Reverse Voltage	V _R	5	V
ESD	ESD _{HBM}	2.0	KV
Operating Temperature Range	T _{OP}	-40~+85	°C
Storage Temperature Range	T _{STG}	-40~+100	°C
Soldering Temperature*2	T _{SD}	260±5	°C

Notes :

- ❖ *1: Duty 1/10, pulse width 0.1ms
- ❖ *2: The maximum of soldering time is 5 seconds in T_{SD}
- ❖ There is no maximum or typical voltage parameter
- ❖ For other ambient, limited setting of current will be depended on de-rating curves

❖ Typical Product Characteristics

Characteristics	Symbol	Value			Unit	Test condition
		Min.	Typ.	Max.		
Forward Voltage	V_F	1.8	...	2.4	V	$I_f=20mA$
Luminous Intensity	I_v	300	...	740	mcd	$I_f=20mA$
Wavelength	λ_d	615	...	630	nm	$I_f=20mA$
Reverse Current	I_R	10	μA	$V_R=5V$
View Angle	2 θ 1/2	...	140		deg	$I_f=20mA$

Notes:

- ❖ Measurement Errors : Forward Voltage : $\pm 0.1V$, Luminous Intensity : $\pm 10\%$ mcd, Wavelength(x,y) : $\pm 1nm/\pm 0.01$
- ❖ Electrical-Optical Characteristics ($T_a=25\text{ }^\circ C$)

❖ Range of Bins

1). Forward Voltage Bins

V_F (V)		
Bin code	Min	Max
EZ	1.8	2.0
FZ	2.0	2.2
GZ	2.2	2.4

2). Intensity Bins

I_v (mcd)		
Bin code	Min	Max
14	300	520
16	520	740

3). Dominant Wavelength

λ_d (nm)		
Bin code	Min	Max
RA	615	620
RB	620	625
RC	625	630

❖ **Electronic-optical Characteristics**

1). Relative Spectral Distribution

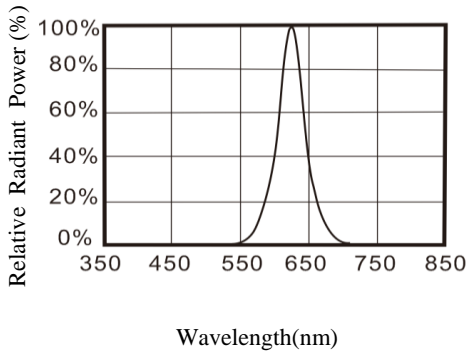

2). Relative Luminous Intensity

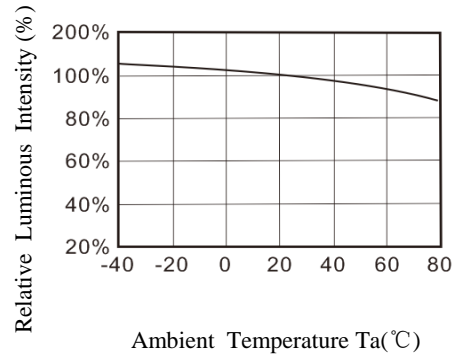

3). Relative Luminous Intensity

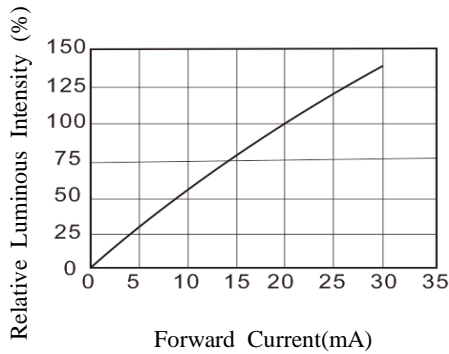

4). Typical Spatial Distribution

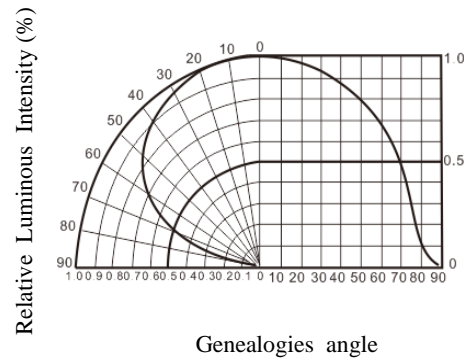

5). Electrical Characteristics

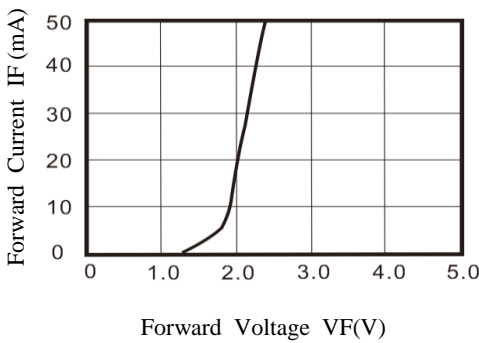

6). Thermal Design

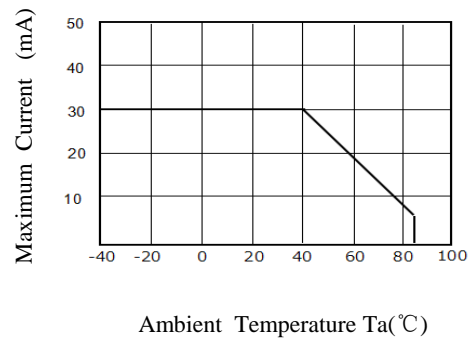

7). Forward Voltage Temperature

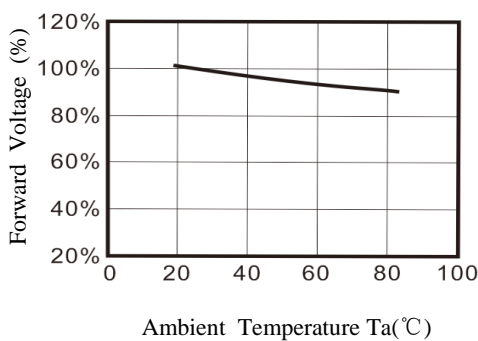

8). Light effect VS Current

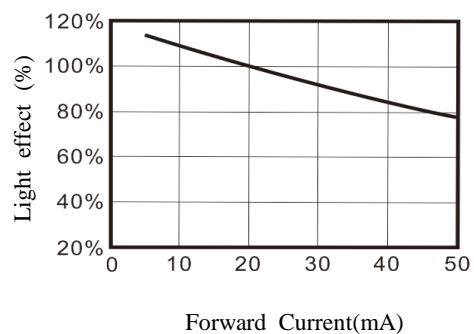

❖ Dimensions

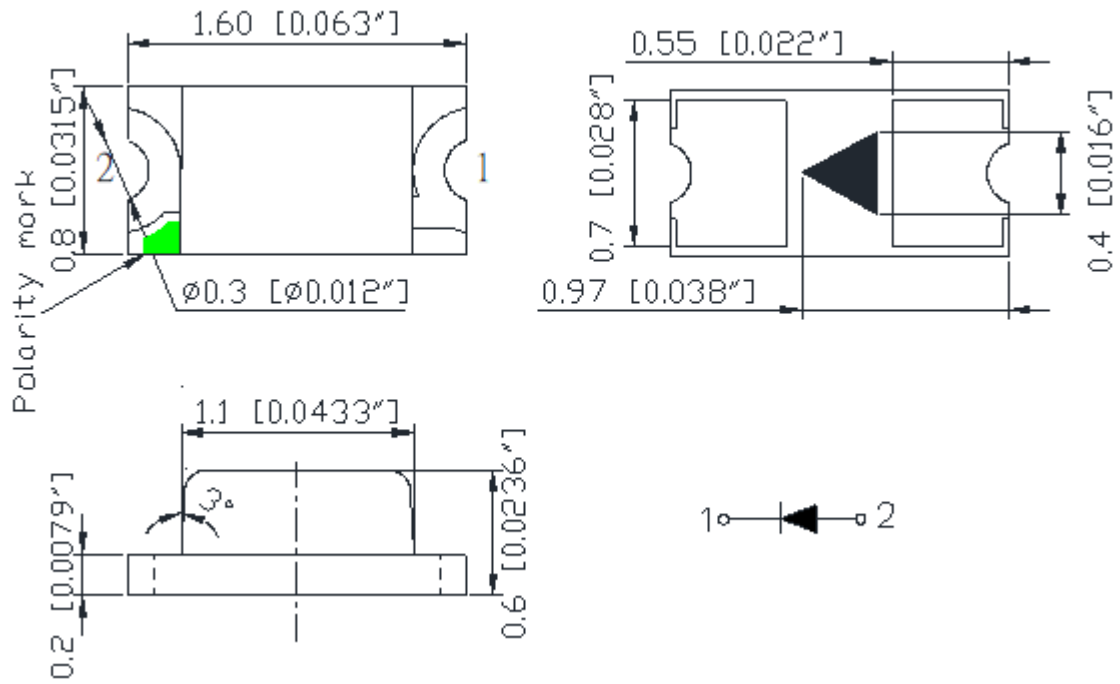

RECOMMEND PADLAYOUT

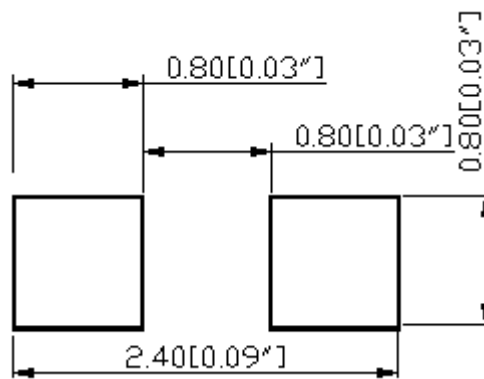

- ❖ All dimensions are in millimeters
- ❖ Tolerance is ± 0.25 (.010) mm unless otherwise noted.

❖ Reflow Profile

1. IR reflow soldering Profile for Lead Free solder

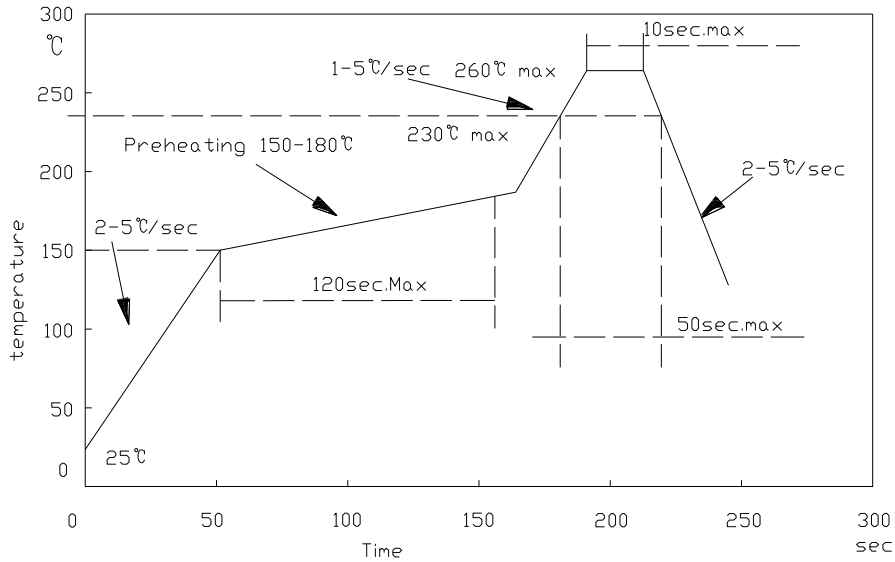

2. IR reflow soldering Profile for Lead solder

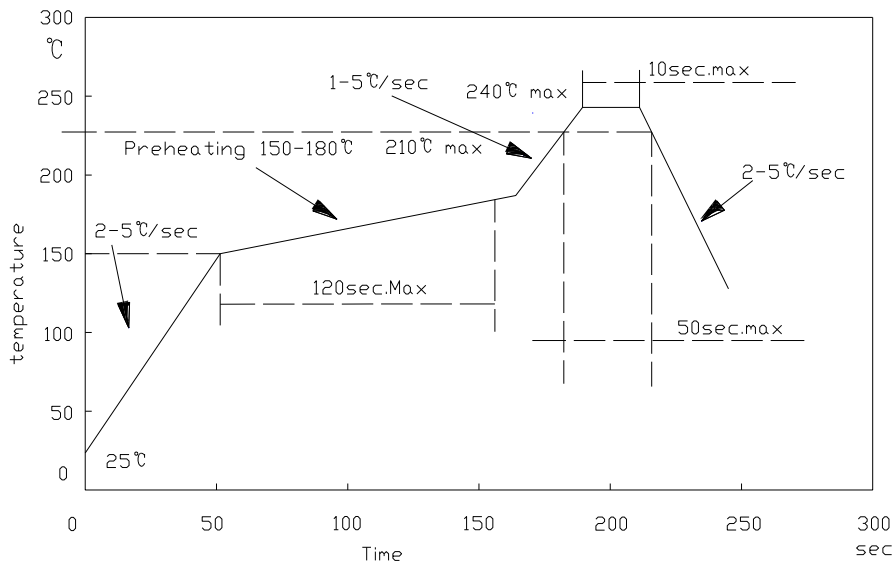

Notes:

- ❖ We recommend the reflow temperature 240°C(±5°C).the maximum soldering temperature should be limited to 260°C
- ❖ Don't cause stress to the silicone resin while it is exposed to high temperature ;
- ❖ Number of reflow process shall be less than 3 times.

❖ **Test Circuit and Handling Precautions**

• **Test circuit**

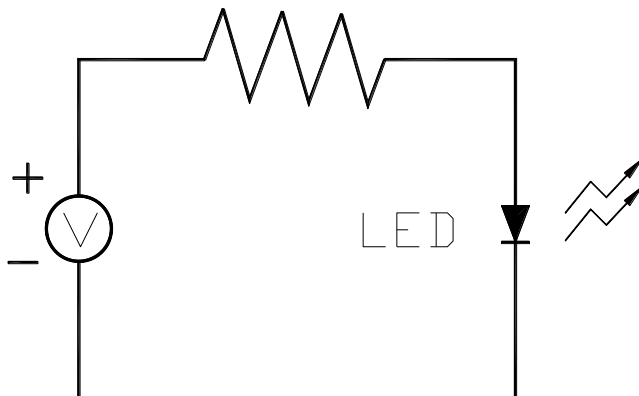

• **Handling precautions**

1. Over-current-proof

Customer must apply resistors for protection, otherwise slight voltage shift will cause big current change (Burn out will happen).

2. Storage

2.1 It is recommended to store the products in the following conditions:

- a. Humidity: 60% R.H. Max.
- b. Temperature : 5°C~30°C(41°F~86°F)

2.2 Shelf life in sealed bag: 12month at < 5°C~30°C and ≤60% R.H. .

2.3 The products more than 6 months must be baked before used. The Conditions of baking as follows:

- a. 65±3°C x(48hrs) and < 5%RH, taped reel type
- b. 150±3°Cx(3hrs), bulk type

2.4 It is recommended that the unfinished products should be stored in sealed antistatic bags after baked.

3. Use environment

Please refer to the IPC/JEDEC J-STD-020 rules of moisture sensitivity levels.

Moisture proof level	Workshop life after packaging and unpacking	
	Time	condition
LEVEL1	Unlimited	≤30°C /85%RH
LEVEL2	1 year	≤30°C /60%RH
LEVEL 2a	4 weeks	≤30°C /60%RH
LEVEL 3	168 hours	≤30°C /60%RH
LEVEL 4	72 hours	≤30°C /60%RH
LEVEL 5	48 hours	≤30°C /60%RH
LEVEL 5a	24 hours	≤30°C /60%RH
LEVEL 6	Out of the box	≤30°C /60%RH

❖ Packing

• Feeding Direction (Unit: mm)

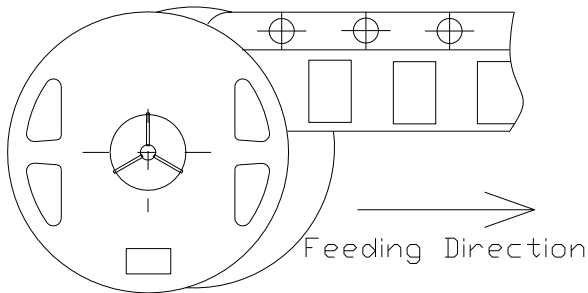

• Dimensions of Reel (Unit: mm)

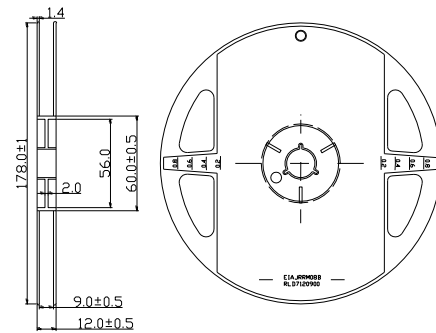

• Dimensions of Tape (Unit: mm)

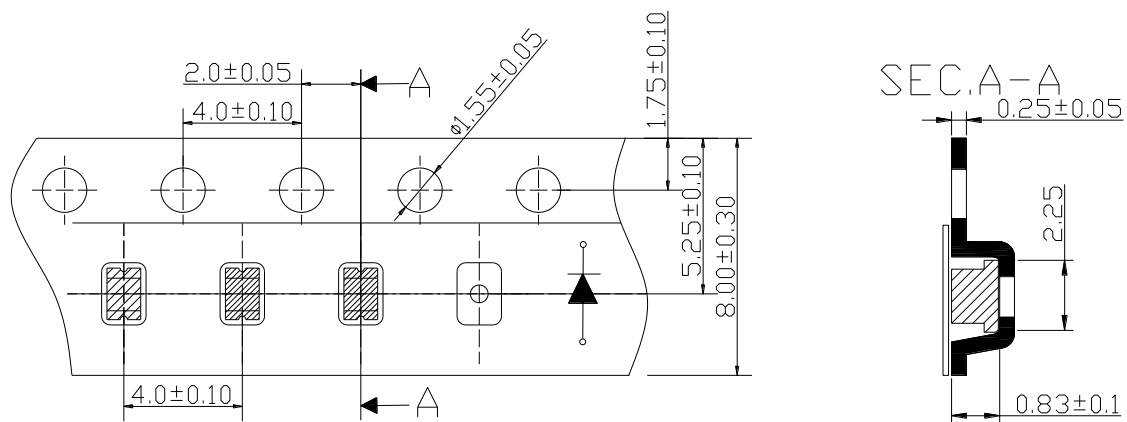

• Arrangement of Tap

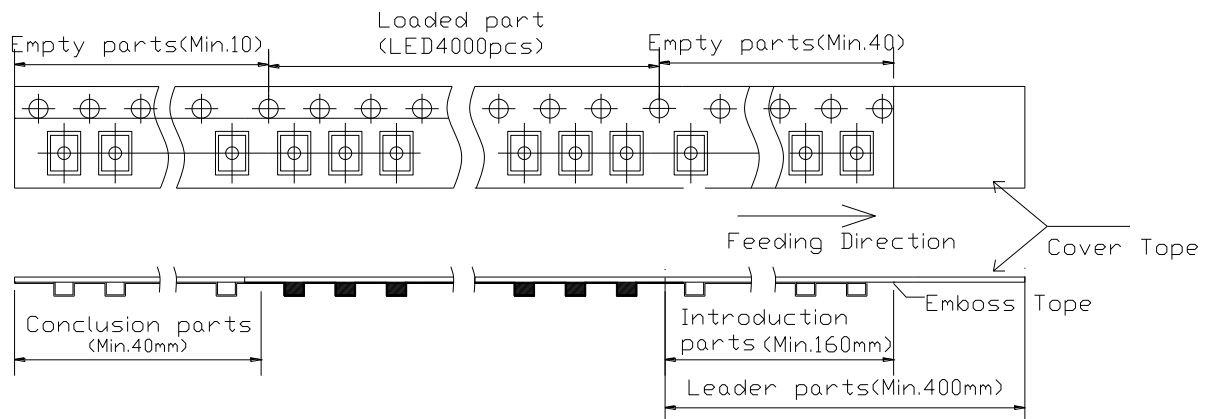

• NOTES:

- ❖ Empty component pockets are sealed with top cover tape
- ❖ The max loss number of SMD is 2pcs
- ❖ The cathode is oriented towards the tape sprocket hole in accordance with ANSI/EIA RS-481 specifications
- ❖ 4,000 pcs per reel

❖ **Packing**

• **Packaging Specifications**

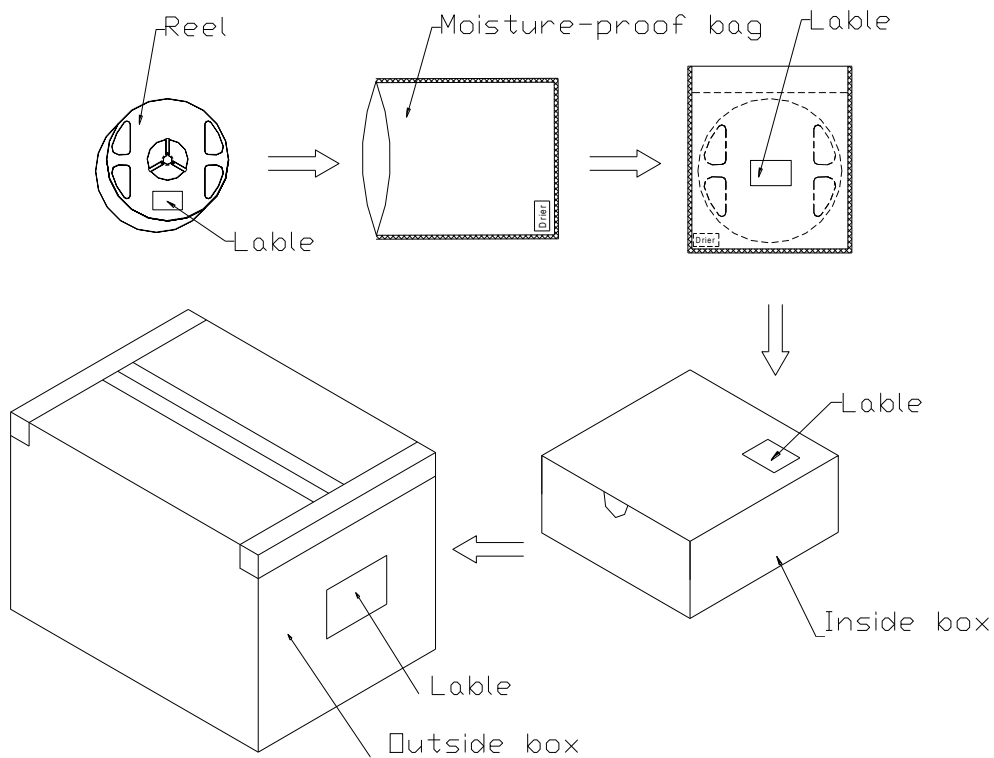

Notes :

Reeled product (max.4,000) is packed in a sealed moisture-proof bag. Sixteen bags are packed in an inner box (size: about 270 X 230 X 260 mm) and tow inner boxes are in an outer box (size: about 562 X 248 X 280mm). On the label of moisture-pooof bag, there should be the information of Part No., Lot No. and quantity number; also the total quantity number should be on inspection request form on outer box.

❖ Precautions

• Abnormal situation caused by improper setting of collet

To choose the right collet is the key issue in improving the product's quality. LED is different from other electronic components, which is not only about electrical output but also for optical output. This characteristic made LED more fragile in the process of SMT. If the collet's lowering down height is not well set, it will bring damage to the gold wire at the time of collet's picking up and loading which will cause the LED fail to light up, light up now and then or other quality problems

• How to choose the collet

During SMT, please choose the collet that has larger outer diameter than the lighting area of lens, in case that improper position of collet will damage the gold wire inside the LED. Different collets fit for different products, please refer to the following pictures cross out

Outer diameter of collet should be larger than the lighting area

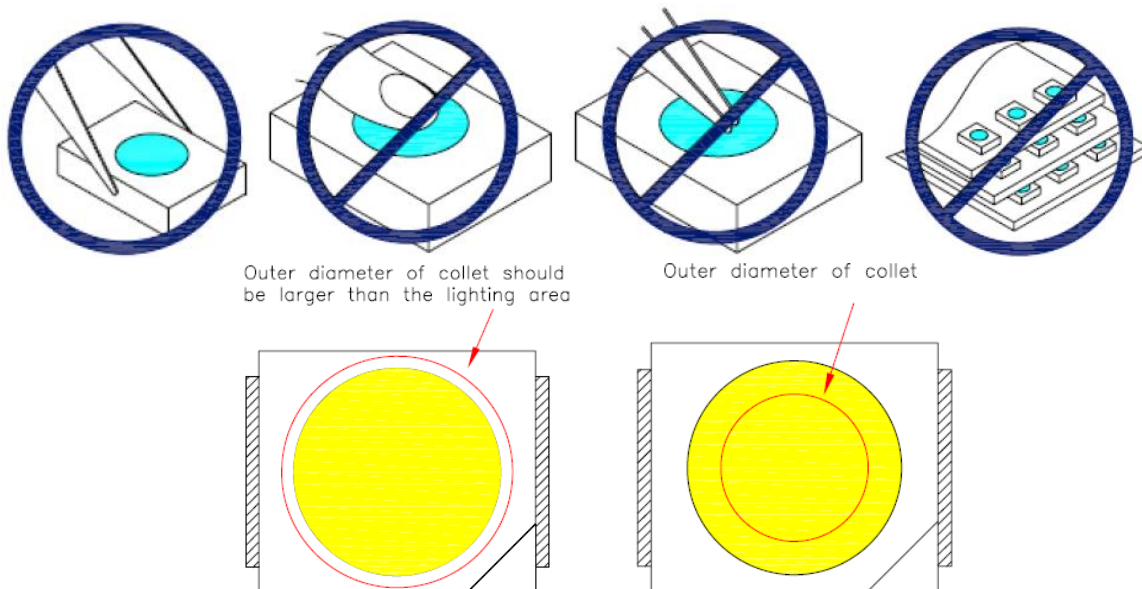

• Other points for attention

- A. No pressure should be exerted to the epoxy shell of the SMD under high temperature.
- B. Do not scratch or wipe the lens since the lens and gold wire inside are rather fragile and cross out easy to break.
- C. LED should be used as soon as possible when being taken out of the original package, and should be stored in anti-moisture and anti-ESD package.

• This usage and handling instruction is only for your reference

❖ Test Items and Results of Reliability

Type	Test Item	Test Conditions	Duration/ Cycle	Number of Damaged	Reference
Environmental Sequence	Temperature Cycle	-40°C 30min ↑↓30 min 105°C 30min	100 cycle	0/26	JEDEC JESD22-A104
	Thermal Shock	-40°C 30min ↑↓5min 105°C 30min	100 cycle	0/26	JEDEC JESD22-A105
	High Temperature Storage	T _a =105°C	1000 hrs	0/26	JEDEC JESD22-A108
	Humidity Heat Storage	T _a =85°C RH=85%	1000 hrs	0/26	JEDEC JESD22-A101
	Low Temperature Storage	T _a =-40°C	1000 hrs	0/26	EIAJED-4701 200 202
Operation Sequence	Life Test	T _a =25°C I _F =20mA	1000 hrs	0/26	EIAJED-4701 100 103
	High Temperature Life Test	T _a =85°C I _F =5mA	1000 hrs	0/26	JEDEC JESD22-A108
	Low Temperature Life Test	T _a =-20°C I _F =20mA	1000 hrs	0/26	EIAJED-4701 200 202

*Criteria for Judging				
Item	Symbol	Condition	Criteria for Judgment of Pass	
			Min	Max
Forward Voltage	V _F	I _F =20mA	~	USL* ¹ ×1.1
Reverse Current	I _R	V _R = 5V	~	10μA
Luminous Intensity	I _v	I _F =20mA	LSL* ² ×0.7	~

Note :

 USL*¹: Upper Specification Level

 LSL*²: Lower Specification Level