

REVISIONS			
REV	DESCRIPTION	DATE	BY

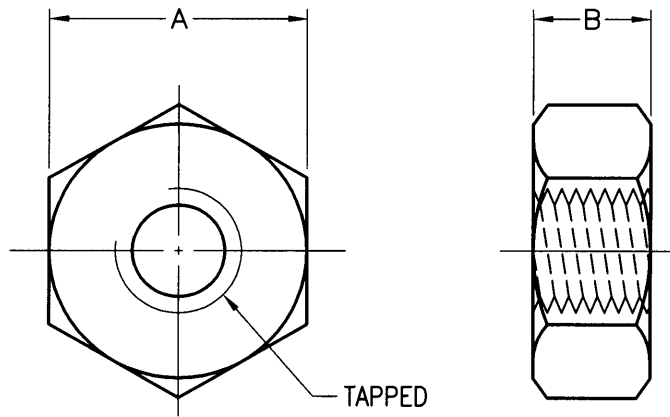

PART NO.	A	B	TAPPED
M-2.6	5.0	2.0	M2.6x0.45
M-3	5.5	2.7	M3x0.5
M-3.5	5.9	2.8	M3.5x0.6
M-4	6.9	3.3	M4x0.7

QMFZ2 Component - Plastics  
 TEIJIN CHEMICALS LTD  
 HIBIYA DAIBIRU BLDG 2-2 UCHISAIWAI-CHO 1-CHOME CHIYODA-KU TOKYO 100-0011 JAPAN  
 Material Designation: L-1225(#)(E2)  
 Product Description: Polycarbonate (PC), designated "Panlite" furnished as pellets, powder.

Color	Min. Thick. (mm)	Flame Class	HWI	HAI	RTI Elec	RTI Imp	RTI Str	IEC GWIT	IEC GWFI
ALL	0.4	V-2	4	3	80	80	80	-	-
	0.75	V-2	3	1	80	80	80	-	-
	1.5	V-2	3	1	125	115	125	-	-
	1.9	HB	3	1	125	115	125	-	-
	3	HB	2	1	125	115	125	-	-
	6	HB	1	1	125	115	125	-	-

CTI: 2 HVTR: 4 D495: 5 IEC Ball Pressure (C): -  
 Dielectric Strength (kV/mm): 30 Volume Resistivity (10<sup>9</sup>ohm-cm): 16 Dimensional Stability(%): 0  
 ISO Tensile Strength (MPa): - ISO Flexural Strength (MPa): - ISO Heat Deflection (C): -  
 ISO Tensile Impact (kJ/m<sup>2</sup>): - ISO Izod Impact (kJ/m<sup>2</sup>): - ISO Charpy Impact (kJ/m<sup>2</sup>): -

(#) Material designation may be suffixed with any one or two letters.  
 (E2) Subjected to one or more of the following tests: Ultraviolet Light, Water Exposure or Immersion in accordance with UL 746C, where the acceptability for outdoor use is to be determined by UL Inc.

Report Date: 2/10/1989

Underwriters Laboratories Inc®

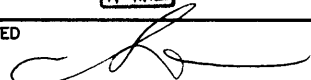
 <p>康揚企業股份有限公司          KANG YANG HARDWARE ENTERPRISE CO., LTD.          東莞康揚塑膠五金電子廠          DONG GUAN KANG YANG PLASTIC HARDWARE COMPANY          康哲電腦配件(吳江)有限公司          KANG CHE COMPUTER COMPONENTS(WUJIANG) CO.,LTD.</p>	TITLE		塑膠螺帽		產品規格圖面		
	MATERIAL		P.C UL94V-2		DATE		1997.07.03
	FINISH		NATURAL		DRAWN		JASON
	COLOR		NATURAL		CHECK		徐瀚瑩
PART NUMBER	DRAWING NUMBER		UNLESS OTHERWISE SPECIFIED TOLERANCE		APPROVED		
SEE ABOVE	M-3H		±0.2				
SIZE	SCALE	UNIT	REV				
A4	NONE	mm	B				