



SPL (HONG KONG) LIMITED

香港九龍觀塘鴻圖道57號南洋廣場17樓1703B室
Room 1703B, 17/F., Nanyang Plaza, No.57 Hung To Road, Kwun Tong, Kowloon, HK.
Tel: 852-2342 6857 / 2342 6867 Fax: 852-2342 6847 Email: sales@spl-hk.com.hk
Website: www.buzzer.com.hk ; www.transducer.com.hk ; www.connector.com.hk

Magnetic Transducer

SMT40 series

DIMENSIONS

Date : 12 Mar.,2021

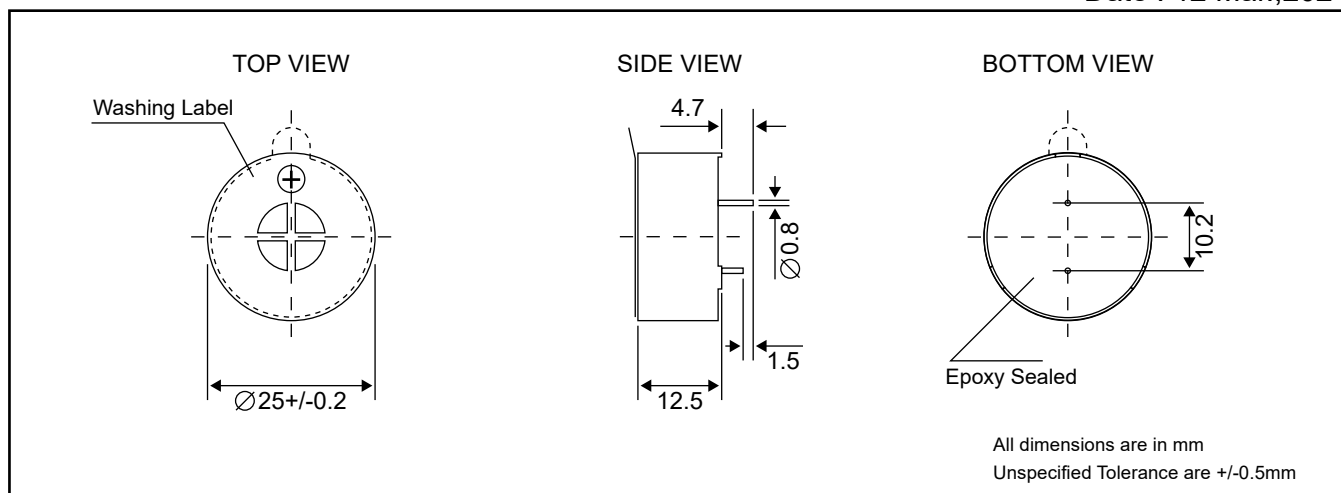

Ref No. : P1031208-R2



ELECTRICAL SPECIFICATIONS

Model No.		MT40-Q12LNPR
Operating Voltage	[Vo-p]	8 ~ 16
Rated Voltage	[Vo-p]	12
* Max. Rated Current	[mA]	55
Coil Resistance	[ohm]	120 +/- 12
* Min. Sound Output	[dBA / 10cm]	104
Resonant Frequency	[Hz]	1500
Heat Test		Must Be Normal [120 +/- 2 °C, 24 Hours]
Cold Test		Must Be Normal [-40 +/- 2 °C, 24 Hours]
Humidity Test		40 +/- 2 °C, 90 ~ 95% R.H. 24 Hours
Operating Temperature	[°C]	-40 ~ +105
Storage Temperature	[°C]	-40 ~ +120
Terminal		Pin
Housing Material		Noryl
Colour		Black
Weight	[gm]	To be advised

Value applying [resonant frequency, sine wave, measuring current 60uA]

* Value applying rated voltage [resonant frequency, 1/2 duty, square wave] and recommended circuit [HFE >200, min.2.5mA]