

■Features

- High luminous Flux LEDs
- 4.8mm Straw Standard Directivity
- UV Resistant Epoxy
- Water Clear Type

■Applications

- Automotive Dashboard Lighting
- Traffic Signal Lamp
- Back Lighting
- Other Lighting

■Outline Dimension

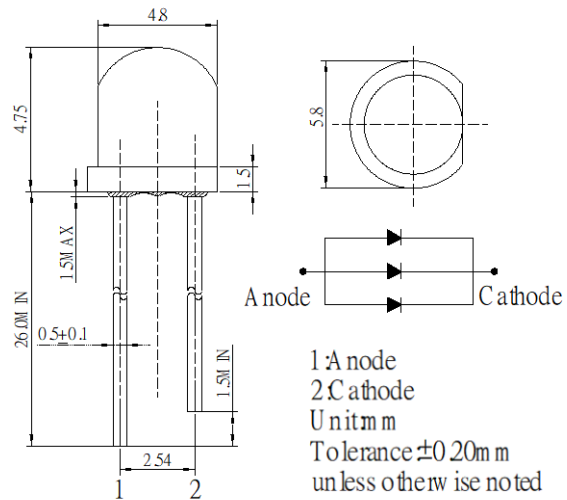

■Absolute Maximum Rating

(Ta=25°C)

Item	Symbol	Value	Unit
DC Forward Current	I _F	75	mA
Pulse Forward Current#	I _{FP}	300	mA
Reverse Voltage	V _R	5	V
Power Dissipation	P _D	195	mW
Operating Temperature	T _{opr}	-30 ~ +85	°C
Storage Temperature	T _{stg}	-40 ~ +100	°C
Lead Soldering Temperature	T _{sol}	260°C/5sec	-

#Pulse width Max.10ms Duty ratio max 1/10

■Directivity

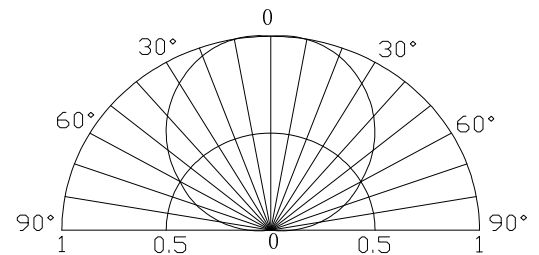

■Electrical -Optical Characteristics

(Ta=25°C)

Item	Symbol	Condition	Min.	Typ.	Max.	Unit
DC Forward Voltage*1	V _F	I _F =60mA	1.8	2.1	2.6	V
DC Reverse Current	I _R	V _R =5V	-	-	30	μA
Domi. Wavelength*2	λ _D	I _F =60mA	619	625	629	nm
Luminous Intensity*3	I _v	I _F =60mA	10000	12000	-	mcd
50% Power Angle	2θ _{1/2}	I _F =60mA	-	120	-	deg

*1 Tolerance of measurements of forward voltage is ±0.1V

*2 Tolerance of measurements of dominant wavelength is ±1nm

*3 Tolerance of measurements of luminous intensity is ±15%

AlGaInP LED

TYPICAL ELECTRICAL/OPTICAL CHARACTERISTIC CURVES

