

■Features

- High Luminous Super Flux Output
- UV Resistant Epoxy
- Long Lifetime Operation
- Water Clear Type

■Applications

- General illumination
- Advertising boards
- Back lighting
- Automotive Lighting

■Outline Dimension

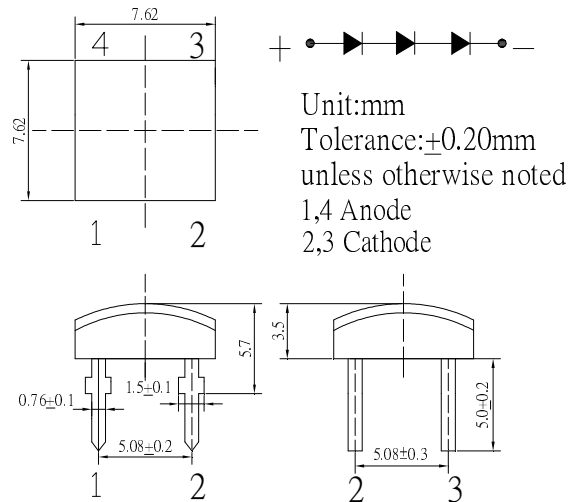

■Absolute Maximum Rating

(Ta=25°C)

Item	Symbol	Value	Unit
DC Forward Current	I _F	30	mA
Pulse Forward Current#	I _{FP}	100	mA
Reverse Voltage	V _R	15	V
Power Dissipation	P _D	306	mW
Operating Temperature	Topr	-30 ~ +85	°C
Storage Temperature	Tstg	-40 ~ +100	°C
Lead Soldering Temperature	Tsol	260°C / 5sec	-

#Pulse width Max.10ms , Duty ratio max 1/10

■Directivity

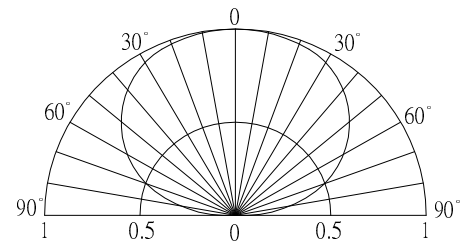

■Electrical -Optical Characteristics

(Ta=25°C)

Item	Symbol	Condition	Min.	Typ.	Max.	Unit
DC Forward Voltage	V _F	I _F =30mA	8.4	8.9	10.2	V
DC Reverse Current	I _R	V _R =15V	-	-	10	μA
Luminous Flux*	Φ _v	I _F =30mA	-	30	-	lm
Luminous Intensity*	I _v	I _F =30mA	7500	9000	-	mcd
Color Temperature	CCT	I _F =30mA	-	10000	-	K
Chromaticity Coordinates*	x	I _F =30mA		0.27		-
	y	I _F =30mA		0.28		-
50% Power Angle	2θ _{1/2}	I _F =30mA	-	140	-	deg

*1 Tolerance of measurements of chromaticity coordinate is ±10%

*2 Tolerance of measurements of Luminous Flux is ±15%

*3 Tolerance of measurements of forward voltage is ±0.1V

InGaN LED

TYPICAL ELECTRICAL/OPTICAL CHARACTERISTIC CURVES

