

### ■ Features

- High luminous Flux LEDs
- 4.8mm Straw Standard Directivity
- UV Resistant Epoxy
- Water Clear Type

### ■ Applications

- Backlighting (illuminated advertising etc.)
- Substitution of Micro Incandescent Lamps
- Reading Lamps / Emergency Lighting
- Marker lights (e.g. steps, exit ways, etc.)
- Other Lighting

### ■ Outline Dimension

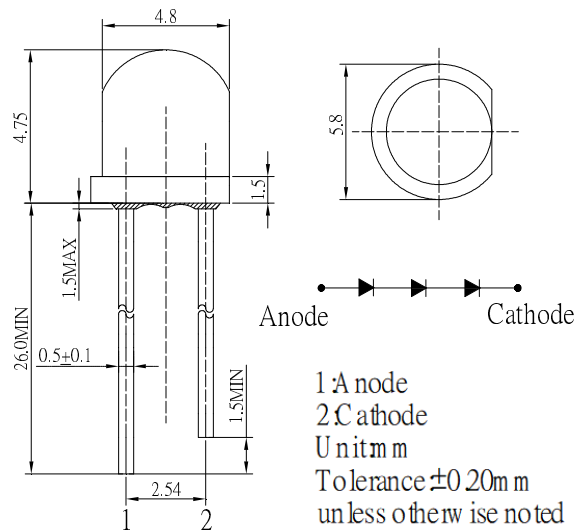

### ■ Absolute Maximum Rating

(Ta=25°C)

Item	Symbol	Value	Unit
DC Forward Current	I <sub>F</sub>	30	mA
Pulse Forward Current#	I <sub>FP</sub>	100	mA
Reverse Voltage	V <sub>R</sub>	15	V
Power Dissipation	P <sub>D</sub>	216	mW
Operating Temperature	T <sub>opr</sub>	-30 ~ +85	°C
Storage Temperature	T <sub>stg</sub>	-40 ~ +100	°C
Lead Soldering Temperature	T <sub>sol</sub>	260°C/5sec	-

#Pulse width Max 10ms , Duty ratio max 1/10

### ■ Directivity

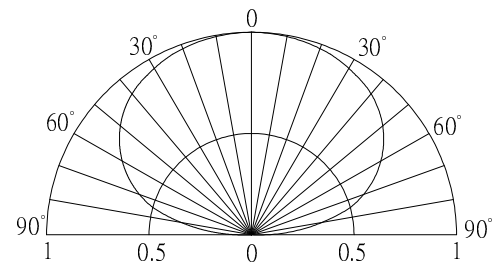

### ■ Electrical -Optical Characteristics

(Ta=25°C)

Item	Symbol	Condition	Min.	Typ.	Max.	Unit
DC Forward Voltage*1	V <sub>F</sub>	I <sub>F</sub> =20mA	8.7	9.3	10.8	V
DC Reverse Current	I <sub>R</sub>	V <sub>R</sub> =15V	-	-	10	μA
Luminous Flux*2	Φ <sub>v</sub>	I <sub>F</sub> =20mA	-	25	-	lm
Color Temperature*3	CCT	I <sub>F</sub> =20mA	-	8000	-	K
Chromaticity Coordinates*4	x	I <sub>F</sub> =20mA	-	0.29	-	
	y	I <sub>F</sub> =20mA	-	0.31	-	
50% Power Angle	2θ <sub>1/2</sub>	I <sub>F</sub> =20mA	-	150	-	deg

\*1 Tolerance of measurements of forward voltage is ±0.1V

\*2 Tolerance of measurements of luminous flux is ±15%

\*3 Tolerance of measurements of color temperature is ±10%

\*4 Tolerance of measurements of chromaticity coordinates is ±10%

**InGaN LED**

**TYPICAL ELECTRICAL/OPTICAL CHARACTERISTIC CURVES**

