

# PQ1CG38M2FZ

# PQ1CG38M2RZ

## TO-220 Type Chopper Regulator

### General Description

Sharp's chopper regulator PQ1CG38M2FZ/PQ1CG38M2RZ of TO-220 package uses PWM method.

It is suitable for the applications of large voltage difference between input and output and applications of negative power supply thanks to its low heat loss.

### Features

1. Maximum switching current:0.8A
2. Built-in ON/OFF control function
3. Built-in soft start function to suppress overshoot of output voltage in power on sequence or ON/OFF control sequence
4. Built-in oscillation circuit  
(Oscillation frequency:TYP. 300kHz)
5. Built-in overheat/overcurrent protection function
6. TO-220 package
7. Variable output voltage  
(Output variable range: $V_{REF}$  to  $35V/-V_{REF}$  to  $-30V$ )  
[Possible to select step-down output/inverting output according to external connection circuit]
8. **PQ1CG38M2FZ**:Zigzag forming  
**PQ1CG38M2RZ**:Self-stand forming

### Applications

1. Switching power supplies
2. Facsimiles, printers and other OA equipment
3. Battery chargers
4. Personal computers and amusement equipment

### Outline Dimensions

(Unit : mm)

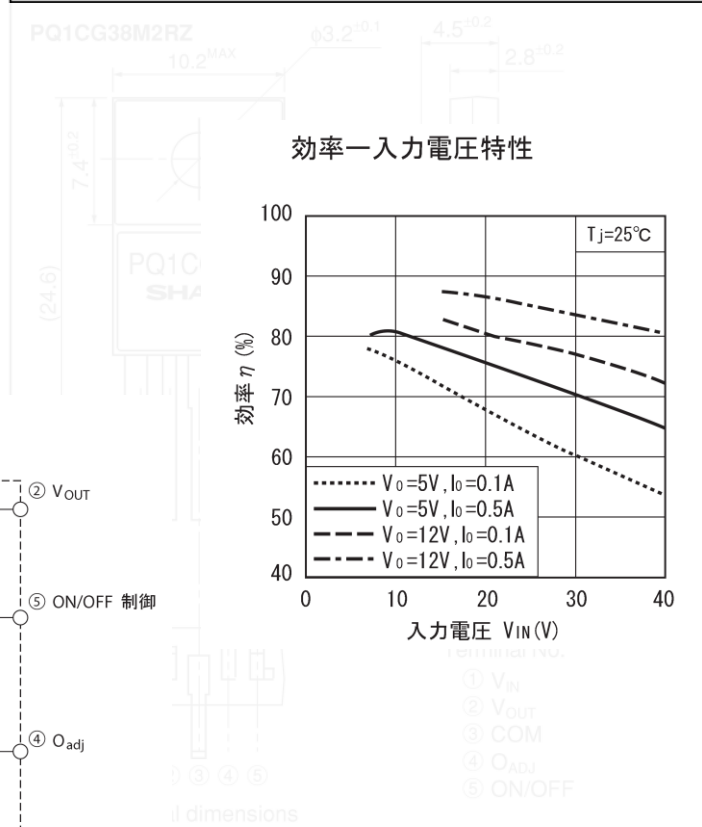
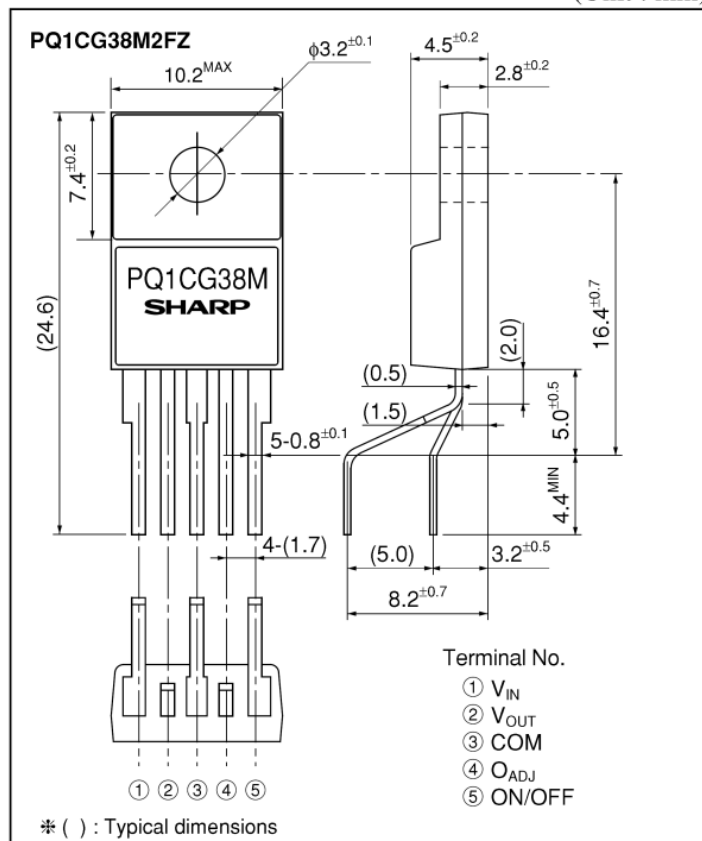

ブロック図

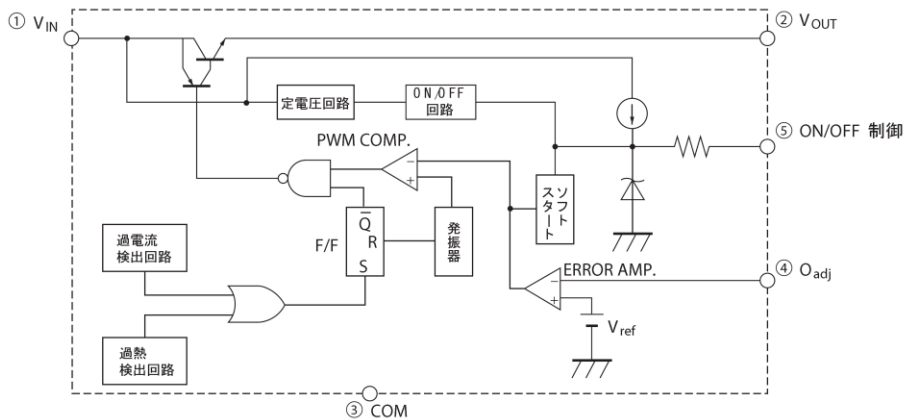

■ Absolute Maximum Ratings (T<sub>a</sub>=25°C)

Parameter	Symbol	Rating	Unit
*1 Input voltage	V <sub>IN</sub>	40	V
Output adjustment terminal voltage	V <sub>ADJ</sub>	7	V
Dropout voltage	V <sub>I-O</sub>	41	V
*2 Output to COM voltage	V <sub>OUT</sub>	-1	V
*3 ON/OFF control voltage	V <sub>C</sub>	-0.3 to +40	V
*4 Power dissipation	I <sub>SW</sub>	0.8	A
	P <sub>D1</sub>	1.4	W
*5 Junction temperature	P <sub>D2</sub>	14	W
	T <sub>j</sub>	150	°C
Operating temperature	T <sub>opr</sub>	-20 to +80	°C
Storage temperature	T <sub>stg</sub>	-40 to +150	°C
Soldering temperature	T <sub>sol</sub>	260 (for 10s)	°C

- \*1 Voltage between V<sub>IN</sub> and COM
- \*2 Voltage between V<sub>OUT</sub> and COM
- \*3 Voltage between ON/OFF and COM
- \*4 P<sub>D1</sub>: No heat sink P<sub>D2</sub>: With infinite heat sink
- \*5 Overheat protector may operate for T<sub>j</sub>=125 to 150°C

過電流保護特性 (代表値)

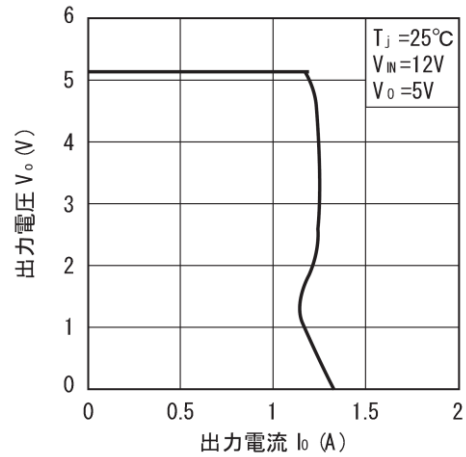

■ Electrical Characteristics (V<sub>IN</sub>=12V, I<sub>O</sub>=0.2A, Terminal No.5 open and T<sub>a</sub>=25°C unless otherwise specified)

Parameter	Symbol	Conditions	MIN.	TYP.	MAX.	Unit
Output saturation voltage	V <sub>SAT</sub>	I <sub>SW</sub> =0.5A	-	0.95	1.5	V
Reference voltage	V <sub>REF</sub>	-	1.235	1.26	1.285	V
Reference voltage temperature fluctuation	ΔV <sub>REF</sub>	T <sub>j</sub> =0 to 125°C	-	±0.5	-	%
Load regulation	R <sub>egL</sub>	I <sub>O</sub> =0.1 to 0.5A	-	0.2	1.5	%
Line regulation	R <sub>egI</sub>	V <sub>IN</sub> =8 to 35V	-	1	2.5	%
Efficiency	η	I <sub>O</sub> =0.5A	-	80	-	%
Oscillation frequency	f <sub>O</sub>	-	270	300	330	kHz
Oscillation frequency temperature fluctuation	Δf <sub>O</sub>	T <sub>j</sub> =0 to 125°C	-	±3	-	%
Overcurrent detection level	I <sub>L</sub>	-	0.85	1.2	1.6	A
Charge current	I <sub>CHG</sub>	②, ④ terminals is open, ⑤ terminal	-	-10	-	μA
Input threshold voltage	V <sub>THL</sub>	Duty ratio=0%, ④ terminal=0V, ⑤ terminal	-	1.3	-	V
	V <sub>THH</sub>	Duty ratio=100%, ④ terminals=1.1V, ⑤ terminal	-	2.1	-	V
ON threshold voltage	V <sub>TH(ON)</sub>	④ terminal=0V, ⑤ terminal	0.7	0.8	0.9	V
Standby current	I <sub>SD</sub>	V <sub>IN</sub> =40V, ⑤ terminal=0V	-	120	400	μA
Output OFF-state consumption current	I <sub>QS</sub>	V <sub>IN</sub> =40V, ⑤ terminal=0.9V	-	5	10	mA

Fig.1 Step Down Voltage Output Circuit Diagram

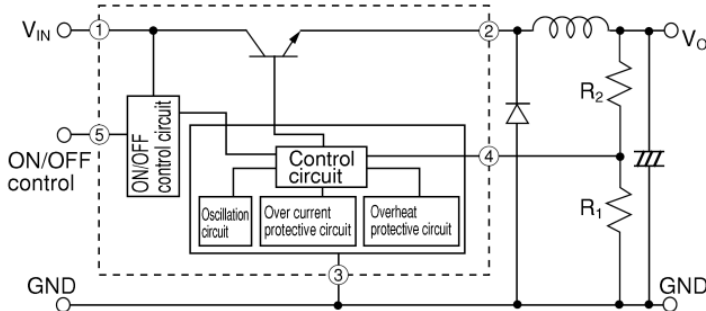

$$V_O = V_{REF} \times (1 + R_2/R_1)$$

$$V_O = V_{REF} \text{ to } +35V \quad (V_{REF} \approx 1.26V)$$

Here, the upper limit is restricted by V<sub>IN</sub>-V<sub>SAT</sub> value according to the input.

Fig.2 Inverting Output Circuit Diagram

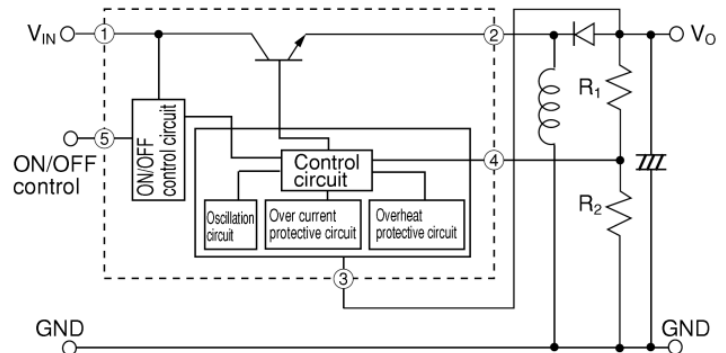

$$V_O = -V_{REF} \times (1 + R_2/R_1)$$

$$V_O = -V_{REF} \text{ to } -30V \quad (V_{REF} \approx 1.26V)$$

Here, the upper limit of the absolute value is restricted by 40V-V<sub>IN</sub> according to the input.