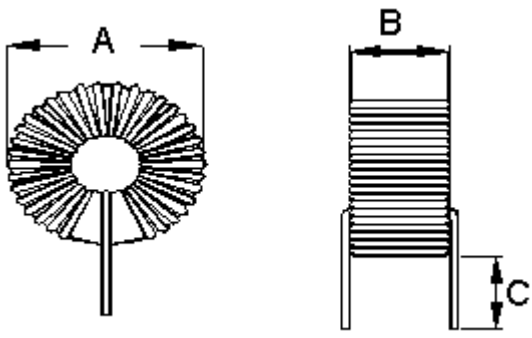
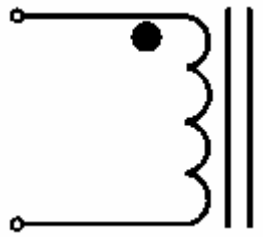

SPECIFICATION FOR APPROVAL

CUSTOMER:		DATE:	
PART NO: TCV-221M-2A-5026		DWG.NO: HX1508118	
CUSTOMER PART NO:		CUST.DWG.NO:	
(1) DIMENSION(UNIT: mm) 		A	15.0 (MAX) m/m
		B	7.0 (MAX) m/m
		C	10.0 ± 2.0 m/m
		D	m/m
		E	m/m
		F	m/m
		G	m/m
		H	m/m
		I	m/m
		J	m/m
		(2) ELECTRICAL REQUIREMENTS	
L (uH)	220 ± 20%		
RDC (Ω)	0.8 (MAX)		
IDC (A)	2 (MAX)		
TEST CONDITION	1KHZ / 0.25V		
(4) REMARK CORE:T50-26 WIRE:2UEW Φ0.4mm TURN:68.5TS (REF)		APPROVED BY 吳載敏	
		CHECKED BY 張明德	
		DRAWN BY 黃慧診	

CORE MASTER ENTERPRISE CO., LTD.

TEL:886-2-8919-1288 FAX:886-2-8919-1298 WEB:www.coremaster.com.tw

TEST DATA

CUSTOMER:				DATE:				
PART NO: TCV-221M-2A-5026				DWG.NO: HX1508118				
CUSTOMER PART NO :				CUST.DWG.NO :				
TEST CONDITION: 1KHZ / 0.25V				DIMENSION (UNIT : mm)				
ITEM	L (uH)	RDC (Ω)	IDC (A)	A	B	C		
SPEC	220 ± 20%	0.8 (MAX)	2 (MAX)	15.0 (MAX)	7.0 (MAX)	10.0 ± 2.0		
1	205.7	0.639	OK	14.27	6.61	9.70		
2	196.9	0.623	OK	14.16	6.46	9.69		
3	203.7	0.631	OK	14.21	6.42	9.78		
4	206.9	0.645	OK	14.27	6.61	9.70		
5	205.6	0.641	OK	14.16	6.46	9.69		
6	196.9	0.623	OK	14.12	6.53	9.71		
7	203.7	0.631	OK	14.35	6.49	9.65		
8	205.7	0.639	OK	14.12	6.53	9.71		
9	196.9	0.623	OK	14.27	6.61	9.70		
10	203.7	0.631	OK	14.16	6.46	9.69		
\bar{X}	202.57	0.633		14.209	6.518	9.702		
R	10	0.022		0.23	0.19	0.13		
TEST INSTRUMENTS CH-1062LCR CH-502BC						APPROVED BY		
						吳載敏		
						CHECKED BY		
			張明德					
			DRAWN BY					
			黃慧診					

CORE MASTER ENTERPRISE CO., LTD.

TEL:886-2-8919-1288 FAX:886-2-8919-1298 WEB:www.coremaster.com.tw