

*開關產品未經SWITRONIC同意，請勿拆解，否則無法負品質及安全責任。
Please do not decompose the switch without any permission from SWITRONIC, otherwise the quality and safety responsibility could not be guaranteed.

*本圖面若與目錄之規格尺寸不符，以本圖面規格尺寸為主。
Below is our main specification if different from catalog.

RoHS compliant

P.C.B. LAYOUT

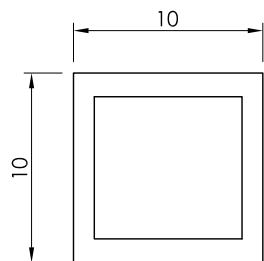
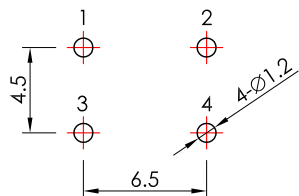

CIRCUIT

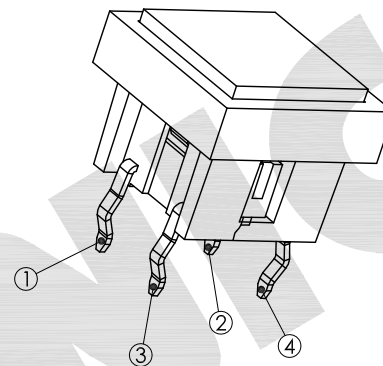
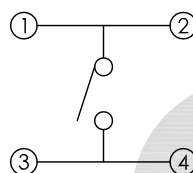

RoHS compliant

TS-A~~XXX~~H-~~XXX~~G-G

HOUSING COLOR	
G	Light Gray
B	Black

CAP COLOR	
R	Red
GN	Green
B	Black
G	Gary
W	White
O	Orange

OPERATING FORCE
180 , 250

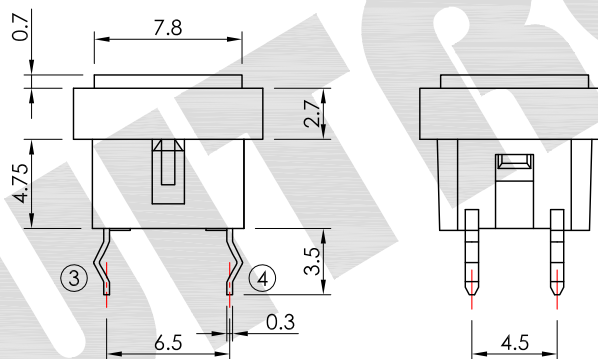

SPECIFICATION

Rating: 50mA 12V DC.
Circuit: SPST.
Function: OFF-(ON).
Travel: 0.25±0.1mm.
Contact resistance: 100mΩ Max.(initial)
Insulation resistance: 100MΩ Min. at 100V DC.
Withstand voltage: 250V AC for 1 minute.
Operating temperature: +10°C ~ +60°C.
Operating force: 180±50g.
Life: 100,000 Cycles Min.
Soldering temperature: 250°C Max. for 3 seconds.
Soldering time: 1 time only.
Note1: Unwashable, don't be immersed by epoxy and organic solvent.
Note2: Please do not scale the drawing comparing to real product and kindly measure the size of real product.

MATERIAL

Base frame: Nylon46, UL-94V-2 Min.
Outer frame: Nylon66, UL-94V-2 Min.
Actuator: PBT, UL-94V-2 Min.
Cap: ABS.
Terminal: Brass, Silver plated.

STORAGE METHOD

After opening the bag of the switches, please include a desiccant into the bag, then seal it to avoid product oxidation.
打開包裝袋後，請在袋中加入乾燥劑並「密封」，避免產品氧化。



V2.2	無	改版	2015.05.29
V2.1	無	改版	2009.02.27
V2.0	無	新繪製	2005.09.22
版本 VER.	符號 SYMBOL	修改內容 ALTERATION	更新日期 DATE

產品 PRODUCT	Pushbutton Switch		型號 MODEL NO.	TS-AGGNH-180G-G
製圖 DRAWN BY	核圖 CHECKED BY	主管 APPROVED BY	單位 UNIT	mm
Peter Kuo	Chuck Young	Margaret Lee	比例 SCALE	5 : 2
			公差 TOLERANCE	.X=±0.3mm, .XX=±0.2mm

SWITRONIC[®]
INDUSTRIAL CORP.
Switches



一綺電子企業股份有限公司

總公司：110 台北市信義路四段415號13樓之3
13F-3, NO.415, SEC.4, HSIN YI ROAD, TAIPEI, TAIWAN
TEL : 886-2-27290229(Rep.) FAX : 886-2-27582086
URL : www.switronic.com E-MAIL : switches@ms36.hinet.net