



SPL (HONG KONG) LIMITED

香港九龍觀塘鴻圖道57號南洋廣場17樓1703B室
Room 1703B, 17/F., Nanyang Plaza, No.57 Hung To Road, Kwun Tong, Kowloon, HK.
Tel: 852-2342 6857 / 2342 6867 Fax: 852-2342 6847 Email: sales@spl-hk.com.hk
Website: www.buzzer.com.hk ; www.transducer.com.hk ; www.connector.com.hk



ISO 9001:2008
Management
System
ID 9105074689

Ultrasonic Sensor SU16 series

DIMENSIONS

Date : 03 Jun.,2020

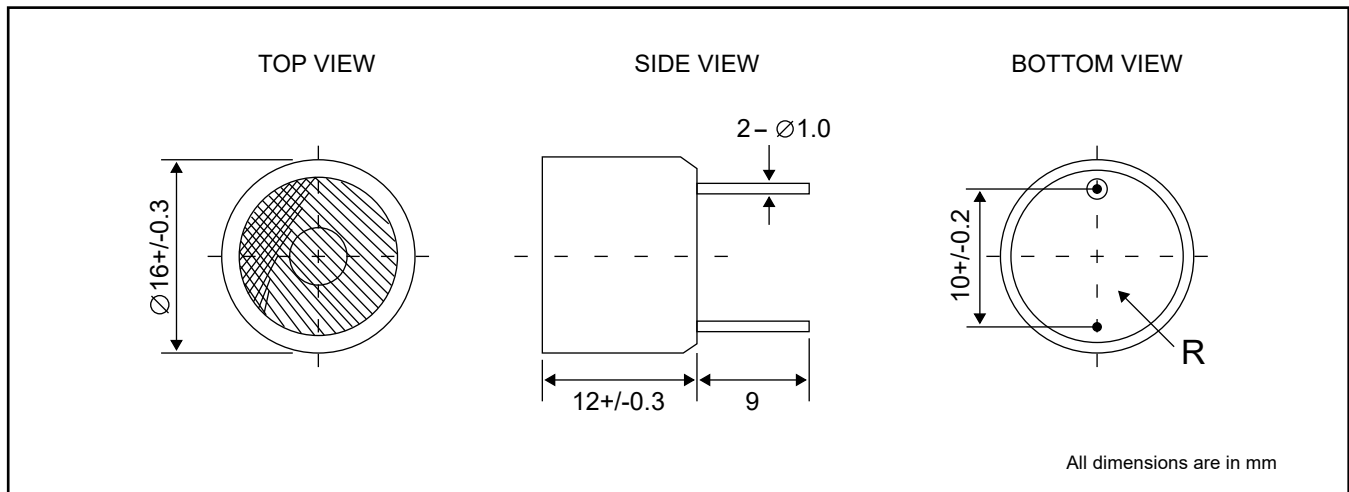

Ref. no. : P104239-1R2

Remark : Bottom with soldering pad



ELECTRICAL SPECIFICATIONS

Model No.		UR1612MPR
Construction		Open Structure
Function		Receiver
Center Frequency	[Hz]	40k +/- 1k
Overall Sensitivity	[dBA]	- 68 min. [0dB = 1V/ubar]
Sound Pressure Level	[at 10Vrms, 30cm]	--
-6dB Direction	[degree]	65 max.
Capacitance	[at 1kHz]	2400 pF +/- 25%
Max. Input Voltage	[Vp-p]	--
Min. Detectable Range	[m]	0.2
Max. Detectable Range	[m]	18
Terminal		Pin
Housing Material		Aluminium
Colour		Silver
Operating Temperature	[°C]	-20 ~ +70
Weight	[gm]	approx. 5