

General Description

The AL1401A OptoGen interface encodes four stereo pairs (8 channels) of digital audio and produces a single data stream suitable for transmission according to the industry-standard ADAT Optical protocol (U.S. patent number 5,297,181).

With an internal PLL to generate all needed clock signals, the AL1401A requires only Word Clock (Fs) for proper operation.

A companion decoder, the AL1402 OptoRec™ is also available.

Use of the ADAT Optical interface (including the OptoGen and OptoRec) requires a license agreement (generally royalty-free) between the manufacturer and Wavefront Semiconductor. Details and agreement information are available upon request from Wavefront directly, or on our web site.

Features

- ❑ Compatible with ADAT® Type I and II formats
- ❑ 4 stereo pairs as inputs using standard DAC formats
- ❑ 4 user bit inputs to transmit time-code, MIDI data, etc.
- ❑ Internal PLL generates required clocks from Word Clock.

Applications

- ❑ Digital Mixing Boards
- ❑ Signal Processors
- ❑ Digital Effects Boxes
- ❑ Digital Recorders
- ❑ Computer Sound Boards
- ❑ Sound Reinforcement Products

Package and pinout

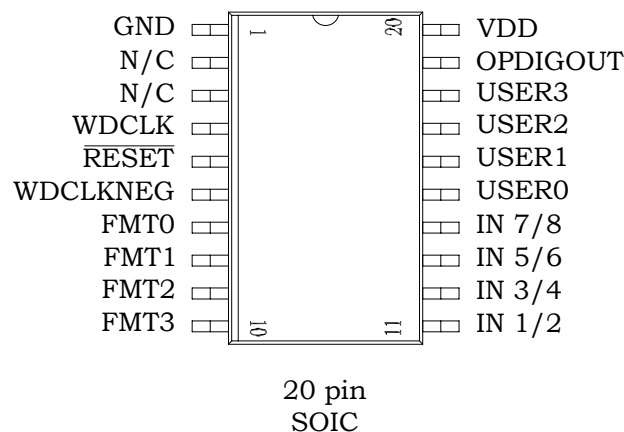

Pin Descriptions

Pin #	Name	Pin Type	Description
1	GND	Power	Ground pin
2	N/C	-	No connection
3	N/C	-	No connection
4	WDCLK	Input	Word clock. Equal to sample frequency (Fs)
5	RESET	Input	Active low reset
6	WDCLKNEG	Input	Sets phase of word clock
7	FMT0	Input	Format0, Sets data format
8	FMT1	Input	Format1. Sets data format
9	FMT2	Input	Format2. Sets data format
10	FMT3	Input	Format3. Sets data format
11	IN 1/2	Input	Channels 1 and 2 data input
12	IN 3/4	Input	Channels 3 and 4 data input
13	IN 5/6	Input	Channels 5 and 6 data input
14	IN 7/8	Input	Channels 7 and 8 data input
15	USER0	Input	User 0 data bit input. Used to transmit timecode.
16	USER1	Input	User 1 data bit input. Used to transmit MIDI data.
17	USER2	Input	User 2 data bit input. Reserved, tie low.
18	USER3	Input	User 3 data bit input. Reserved, tie low.
19	OPDIGOUT	Output	Output to optical driver
20	V _{DD}	Power	+5V power pin

Electrical Characteristics and Operating Conditions

Symbol	Description	Min	Typ	Max	Units
Electrical Characteristics and Operating Conditions					
V _{DD}	Supply Voltage	4.5	5.0	5.5	V
I _{DD}	Supply Current	-	1.5	-	mA
Fs	Sample rate	30	48	55	kHz
Temp	Temperature	0	25	70	°C

Outputs (OPDIGOUT)

V _{OH}	Logical "1" output voltage	0.9 V _{DD}	-	-	V _{DD}
V _{OL}	Logical "0" output voltage	-	-	0.1 V _{DD}	V _{DD}
I _{OH}	Logical "1" output current	-	-	-8	mA
I _{OL}	Logical "0" output current	-	-	8	mA

Inputs (WDCLK, WDCLKNEG, FMT, IN, USER, RESET)

V _{IH}	Logical "1" input voltage	0.75 V _{DD}	-	-	V _{DD}
V _{IL}	Logical "0" input voltage	-	-	0.25 V _{DD}	V _{DD}
I _{IH}	Logical "1" input current	-	-	1	uA
I _{IL}	Logical "0" input current	-	-	1	uA
C _{IN}	Logic Input Capacitance	-	5	-	pF

Formats

Format0	Format1	Format2	Format3	Mode
0	0	0	0	16-bit right justified
1	0	0	0	18-bit right justified
0	1	0	0	20-bit right justified
1	1	0	0	22-bit right justified
0	0	1	0	16-bit left justified
1	0	1	0	18-bit left justified
0	1	1	0	20-bit left justified
1	1	1	0	22-bit left justified
0	0	0	1	Reserved
1	0	0	1	Reserved
0	1	0	1	Reserved
1	1	0	1	Reserved
0	0	1	1	24-bit right justified
1	0	1	1	24-bit left justified
0	1	1	1	Reserved
1	1	1	1	Mute

Format Timing

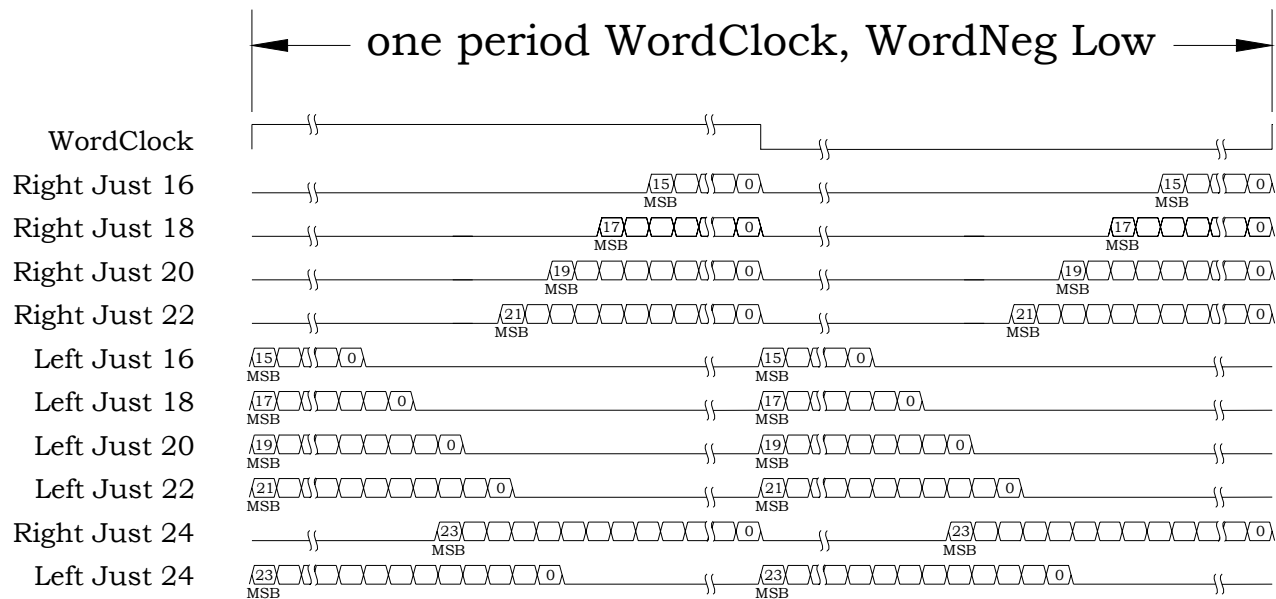

Input Timing

Symbol	Description	Min	Typ	Max	Units
t_{SI}	Setup of IN relative to center of bit period	-	10	30	nsec
t_{HI}	Hold of IN relative to center of bit period	-	10	30	nsec
t_{SU}	Setup of USER relative to end of right channel WDCLK time	-	-	100	nsec
t_{HU}	Hold of USER relative to end of right channel WDCLK time	-	-	100	nsec

Note: Above specifications hold after 2000 WDCLK cycles

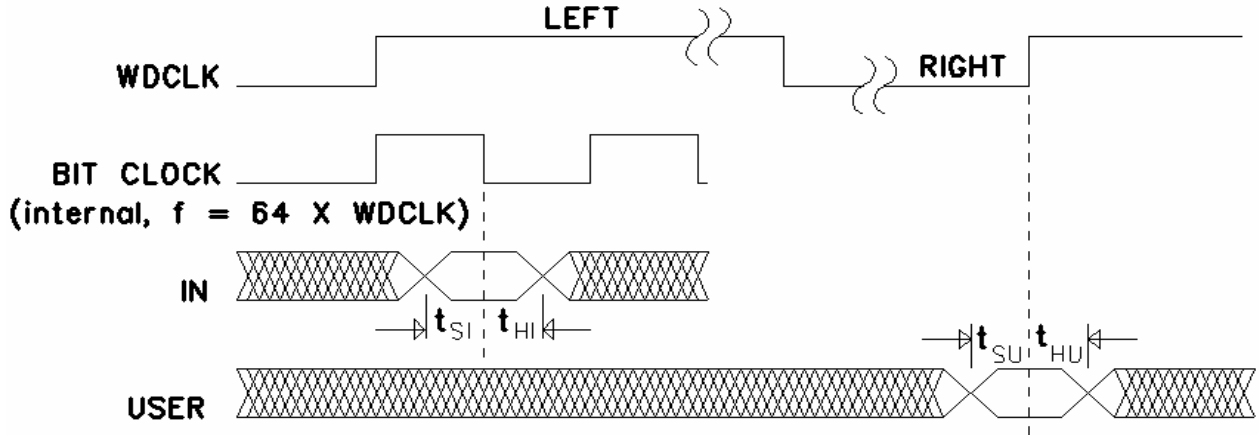

Use

The AL1401A OptoGen™ interface has been designed for ease of use and flexibility in systems designed to interface to the ADAT® protocol. It supports both left and right justified 16, 18, 20, 22 and 24-bit data formats for ease of integration into existing devices as well as new devices. These formats allow it to operate in parallel with many standard DACs.

The designer uses the WDCLKNEG, Format0, Format1, Format2 and Format3 pins to select the desired format.

If WDCLKNEG is high, the falling edge of WDCLK signals the start of a new sample period. If low, the rising edge of WDCLK signals the start of a new sample period. In both cases, the first sample data sent is the odd numbered (left) channel. The second is the even numbered (right) channel.

The format pins are summarized in the Formats table. The AL1401A provides support for both the ADAT Type I format (16-bit) and the ADAT Type II format (20-bit).

USER0 is used to transmit the ADAT format 32-bit timecode. USER1 is used to transmit MIDI data. USER2 and USER3 are reserved and should be tied low. User bits are sampled at the WDCLK edge that indicates the end of right channel data.

Package Information

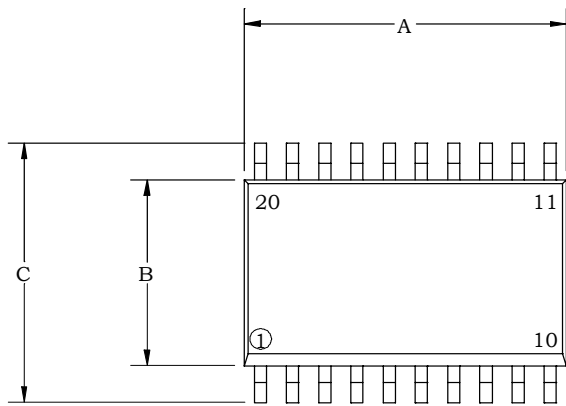

Package Dimensions

Dimensions (Typical)		
	Inches	Millimeters
A	.504"	12.80
B	.295"	7.50
C	.406"	10.30
D	.100"	2.50
E	.008"	0.20
F	.025"	0.64
G	.050"	1.27
H	.017"	0.42
J	.011"	0.27
K	.352"	8.94
L	.033"	0.83

Note: Dimension "A" does not include mold flash, protrusions or gate burrs.

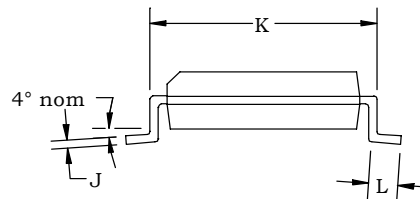
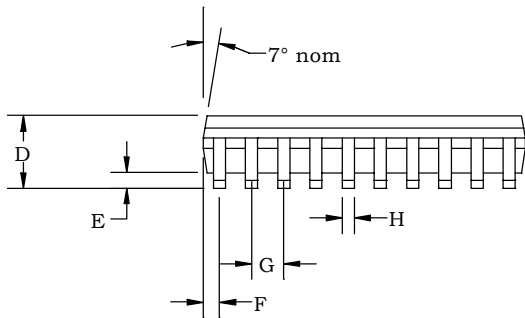

Sample Application Schematic

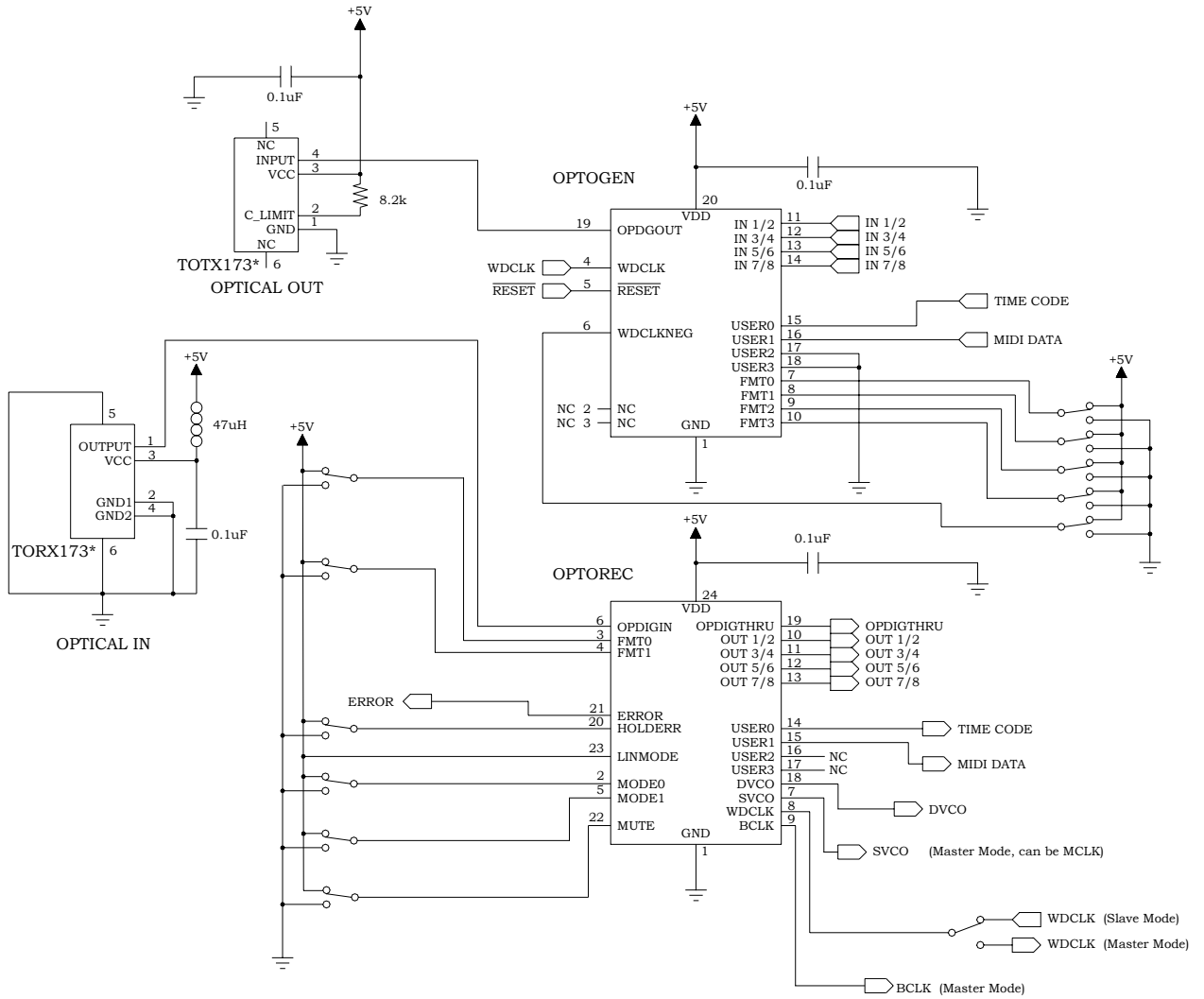

* Optical I/O parts shown are Toshiba parts. The Sharp GP1F33RT or equivalent is also compatible.

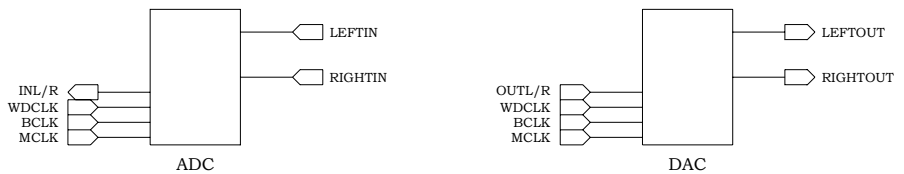

The OptoGen accepts input from an ADC, then outputs the Alesis optical format. The OptoRec accepts input in Alesis optical format, then outputs to a DAC.

NOTICE

Wavefront Semiconductor reserves the right to make changes to their products or to discontinue any product or service without notice. All products are sold subject to terms and conditions of sale supplied at the time of order acknowledgement. Wavefront Semiconductor assumes no responsibility for the use of any circuits described herein, conveys no license under any patent or other right, and makes no representation that the circuits are free of patent infringement. Information contained herein is only for illustration purposes and may vary depending upon a user's specific application. While the information in this publication has been carefully checked, no responsibility is assumed for inaccuracies.

Wavefront Semiconductor products are not designed for use in applications which involve potential risks of death, personal injury, or severe property or environmental damage or life support applications where the failure or malfunction of the product can reasonably be expected to cause failure of the life support system or to significantly affect its safety or effectiveness.

All trademarks and registered trademarks are property of their respective owners.

Contact Information:

Wavefront Semiconductor
200 Scenic View Drive
Cumberland, RI 02864 U.S.A.
Tel: +1 401 658-3670
Fax: +1 401 658-3680
On the web at www.wavefrontsemi.com
Email: info@wavefrontsemi.com

Copyright © 2003 Wavefront Semiconductor

Datasheet September 2003

Reproduction, in part or in whole, without the prior written consent of Wavefront Semiconductor is prohibited.