

Designing with the HCPL-4100 and HCPL-4200 Current Loop Optocouplers



Application Note 1018

Preface

Avago Technologies produces a comprehensive line of optocouplers addressing different speed and current gain requirements for isolation interface circuits. New Avago Technologies' optocoupler products build on the established base of optocoupler technology and offer additional features that make optocouplers easier to use in special applications. The HCPL-4100 (transmitter) and the HCPL-4200 (receiver) optocouplers include specialized circuits for 20 mA digital current loop applications. These optocouplers are designed to easily interface TTL, LSTTL, and CMOS logic systems to current loop systems. An external current source is needed to complete the current loop system.

This application note assists the circuit design engineer in achieving maximum performance from Avago Technologies' HCPL-4100 and HCPL-4200 current loop optocouplers. Practical applications for interfacing to and from a current loop are shown. In addition, overall current loop system aspects and current source designs are discussed. Potential applications of current loops, configurations, types of current sources, and inherent tradeoffs between data rate and length of wire line are also covered.

Introduction

Data transmission between electronic equipment physically separated by distances of more than a few feet can be accomplished in many ways. Wire links, microwave links, and fiber optic links are among the most common means. Each technology has inherent trade-offs in data rate, error rate, simplicity of use, reliability, and cost. Of the wire techniques, a signal can be transmitted as a voltage signal

or a current signal. Many popular industry standards exist for voltage signal transmission, such as RS-232-C, RS-422, RS-423 (serial data transmission), or IEEE-488 (parallel data transmission), etc. When compared to these voltage signal techniques, a current signal or current loop can provide an excellent alternative.

First, some basic definitions are in order. A current loop is a loop which carries a current, generally 20 mA or 60 mA, between electronic equipment via a twisted pair of wires. The loop can be opened and closed by a transmitter within the equipment connected to the loop. These interruptions of current are sensed by other equipment connected to the current loop (receiver). The convention used in this application note for a MARK, or logic 1, corresponds to a presence of loop current, e.g., 20 mA. A SPACE, or logic 0, corresponds to an absence of loop current, i.e., 0 mA. A current loop transmitter or receiver can be either of two types: active (source) or passive (sink). An active transmitter supplies current to the loop. Any receivers or other transmitters within that loop must then be passive units which accept the supplied loop current. Alternatively, an active receiver supplies current to passive transmitters or other passive receivers in the current loop.

Current sources used within a current loop vary in complexity. The simplest current source is a resistor and voltage source. More complex current sources contain active elements or special integrated circuits to provide constant current under various power supply and load conditions. The compliance voltage of a current source is a term used to indicate at what level the current decreases to zero.

There are no widely accepted industry standards for current loops, only accepted conventions. Common digital current loops are 0–20 mA and 0–60 mA, while the analog current loop is 4–20 mA. These levels were originally associated with digital teleprinter equipment and analog industrial sensors such as thermocouples, strain gauges, etc. The HCPL-4100 and HCPL-4200 optocouplers address only the 20 mA digital current loop applications.

Basic Advantages of Current Loops

In voltage-based transmission lines, a voltage signal attenuates over distance. A current loop design ensures constant current through the loop resulting in no signal attenuation. Noise immunity is higher with current loop systems. A constant current maintains a high signal-to-coupled noise ratio. The voltage signal attenuation reduces this ratio.

Even with expensive, low capacitance cable, RS-232-C wire communication over distances greater than 60 m (200 ft.) at 20 kBd is impractical. RS-232-C wire distances are severely limited when compared to current loop distances at the same operating data rate. Current loop systems employ inexpensive twisted pair wire cable. Serial data transmission is accomplished by a simple two-wire arrangement. Multiple stations can be connected in series provided sufficient compliance voltage is available. Unlike voltage techniques, if a fault should open the loop, permanent loop current disruption could be sensed.

Optocouplers can be used in current loops to provide optical isolation of the logic circuits from the current loop circuit. This optical isolation prevents ground potential differences or common mode influences from affecting the current loop

performance. Optocoupler construction and sophisticated integrated circuit processing achieve excellent common mode rejection (10 kV/ μ s). Electrical independence between input and output circuits of an optocoupler permit different reference grounds on either side of the interface.

The maximum data rate of a 20 mA current loop system is determined by the characteristics of the transmitter and receiver and the length and characteristics of the transmission line. For short transmission lines, less than 40 m (131 ft.), the maximum data rate is approximately 120 kBd for the HCPL-4100 and approximately 4.5 MBd for the HCPL-4200.

The small eight pin dual-in-line plastic package results in a savings of printed circuit board space. Standard automatic insertion equipment can be used.

The easy design and implementation of a 20 mA current loop using the HCPL-4100 and HCPL-4200 permits rapid design, fabrication, and testing.

Current Loop Applications

Current loops are used because they offer communications link lengths up to 10 km, have high immunity to errors caused by noise, and have a low cost. Previous 20 mA current loop designs were often limited to 5 or 10 kBd speeds even for short line lengths. Avago Technologies' 20 mA current loop transmitters and receivers are capable of 20 kBd at 400 meters.

In the industrial control industry, current loops are used when there is a need to communicate digital information. Because of the proliferation of the microprocessor and advances in digital circuitry and software, digital control of industrial processes

is becoming widely accepted. Micro, mini, and mainframe computers are distributed throughout the factory and need to exchange information. The same considerations apply where distributed data processing equipment is used in a factory environment for inventory control or workflow monitoring. Avago Technologies' 20 mA current loops are a natural choice for noisy environments.

For these applications, 20 mA current loops are desirable because they are resistant to errors caused by noise, eliminate ground loops, can be used in communications links up to 10 km long, are low cost, and can be easily installed. No other common communications system offers all these features.

Avago Technologies' Current Loop Optocouplers

General Design Considerations with Optocouplers

When ordinary optocouplers are used as the interface between logic systems and a current loop, and vice versa, special care must be taken in certain aspects of the design. The light emitting diode (LED) in a current loop receiver must be protected from current overstress. A threshold needs to be established with hysteresis in order to define the MARK and SPACE conditions and to avoid possible noise effects. The threshold circuit should be located prior to the optical isolation to prevent the current transfer ratio (CTR) changes within an optocoupler over time from influencing established threshold levels. This input protection/threshold circuit should be powered solely by the current loop to maintain isolation and reduce power supply requirements.

The receiver output circuit should be simple to interface to TTL or CMOS systems. The total current

loop receiver circuit needs to occupy minimal board space within the loop station equipment. Of course, the design must satisfy ever increasing speed requirements.

Similar considerations exist for current loop transmitter design. The transmitter operates from either a TTL or CMOS input data signal. The output of the transmitter should be protected and buffered to handle the loop current and compliance voltage level of the current source. Output protection needs to be provided to prevent a miswired connection of the current loop to the transmitter terminals. The output circuit must be powered by the current loop source. If a power failure occurs to the transmitter, the transmitter must remain ON in order to prevent obstruction of data on the current loop. Other subtle effects, such as the type of current source and termination used, also influence the speed performance of the loop.

These design considerations have been incorporated into the HCPL-4100 and HCPL-4200 to simplify the circuit designer's task.

Features Common to the HCPL-4100 (Transmitter) and the HCPL-4200 (Receiver)

The Avago Technologies' current loop optocoupler product family consists of two devices: a current loop transmitter (HCPL-4100) and a current loop receiver (HCPL-4200). Their unique characteristics are explained by first discussing the features common to both devices and then addressing the particular characteristics of each device.

Optical isolation is provided within each device to permit electrical independence of the logic systems

from the current loop system. Electrical independence specifically means two things—signal isolation capability between the two systems and insulation capability between the two systems. Signal isolation is the ability of the device to reject common mode signal interference. The common mode rejection capability of both the HCPL-4100 and the HCPL-4200 is typically 10 kV/ μ s with a specified minimum of 1000 V/ μ s. The device insulation capability is the ability to withstand a transient potential difference stress between the two systems. The Withstand Test Voltage is 3 kV DC for five seconds.

The speed performance of each device has a typical propagation delay of 0.2–0.3 μ s with a specified maximum of 1.6 μ s over 0°C to 70°C, excluding transmission line delay. Depending upon the location of the current source within a loop, data rates of 1.5 MBd for 250 meters loop length is achieved with the HCPL-4200 receiver. Up to 75 kBd for 100 meters of loop length with the HCPL-4100 transmitter is also achieved.

The transmitter input and receiver output are compatible with TTL, LSTTL, and CMOS logic levels. Passive current loop switching or monitoring is performed by integrated circuits (ICs) within each device which are powered from an external 20 mA current source. No additional design for power supplies or buffer circuitry is needed for either unit. Current protection of up to ± 30 mA is provided in each optocoupler. Specific, simple current sources which can be used are explained in a subsequent section.

The HCPL-4100 20 mA current loop transmitter and HCPL-4200 20 mA current loop receiver incorporate these features in eight pin dual-in-line plastic packages. The eight pin dual-in-line package allows for automatic insertion capability and conserves printed circuit board space.

Features of the HCPL-4100 Transmitter

The output integrated circuit of the HCPL-4100 transmitter directly controls a recommended 20 mA loop current. The minimum breakdown voltage of this IC which determines the upper compliance voltage limit of the current source is 27 V DC. At a recommended loop current of 20 mA, the MARK state voltage drop across the output terminals is typically 2.35 V DC. The SPACE state current level is typically 1.1 mA (maximum 2 mA) which powers the output integrated circuit. Should power fail to the input IC of the HCPL-4100 transmitter, the output IC remains in the MARK state. This important feature is needed in multidrop current loop applications.

A minimum capacitive loading of 1000 pF is required for the output IC (loop side) of the transmitter. This guarantees stability of the IC under all possible load conditions. In general, an external 1000 pF capacitor can be omitted for twisted wire cable lengths greater than 30 meters (100 ft.). If there is any possibility of using a wire loop length less than 30 meters, the 1000 pF capacitor must be connected. Good engineering practice is to use a bypassing capacitor (0.1 μ F) from V_{CC} to ground for the input IC of the transmitter. Data from directly connected TTL, LSTTL or CMOS units to the input of the HCPL-4100 transmitter properly

operates this device. A block diagram of the HCPL-4100 is given in Figure 1 and transfer characteristics are illustrated in Figure 2.

Features of the HCPL-4200 Receiver

The HCPL-4200 receiver input IC directly monitors the 20 mA loop current. Power for this IC is supplied by the current loop from the external current source. Loop current level detection is performed prior to the optical isolation.

Specified current thresholds are a minimum of 12 mA for the MARK state and a maximum of 3 mA for the SPACE state. The typical threshold for the MARK state is 6.8 mA with 0.8 mA hysteresis. A guaranteed switching threshold level for the loop current provides additional common mode and differential mode noise immunity and prevents possible current transfer ratio (CTR) changes from affecting loop current threshold levels. At the recommended loop current of 20 mA, the MARK state voltage drop across the input terminals is typically 2.52 V DC.

The output integrated circuit of the HCPL-4200 receiver can have a voltage output (V_O) greater than the power supply voltage (V_{CC}). The absolute maximum voltage level for V_O and V_{CC} is 20 V DC. A third state (high impedance) output enable feature is available for use with bus interface applications or special inhibit functions. The output remains at a high impedance level (third state) if V_{CC} is zero volts. A block diagram of the HCPL-4200 is given in Figure 3 and the transfer characteristic is illustrated in Figure 4. Conventional TTL and LSTTL logic devices can be directly connected to the output of the HCPL-4200 unit. A standard CMOS interface for the HCPL-4200 receiver is given in Figure 5.

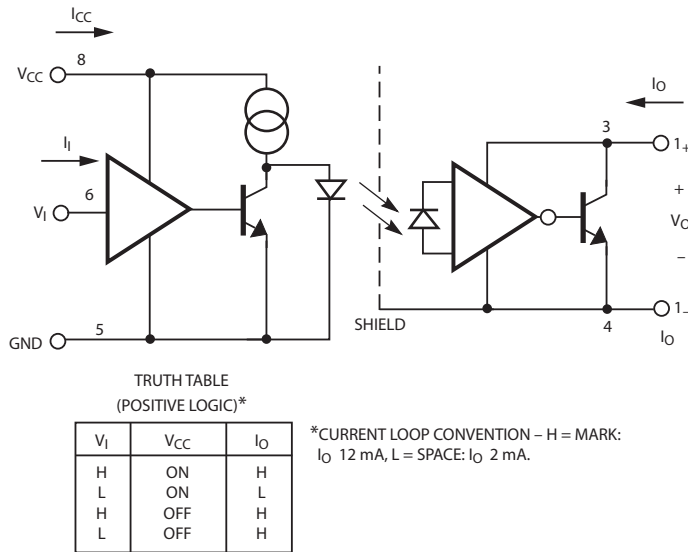

Figure 1. Block Diagram and Truth Table for HCPL-4100 Optocoupler.

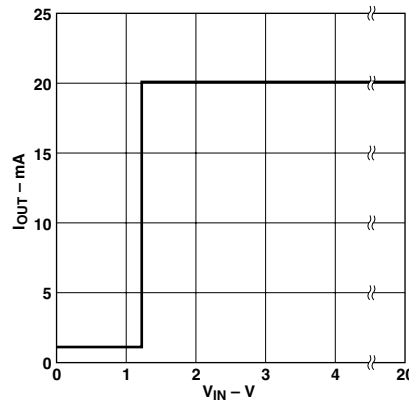

Figure 2. HCPL-4100 Typical Transfer Characteristics. Output Loop Current vs. Input Voltage. MARK State Loop Current is Provided by External Current Source.

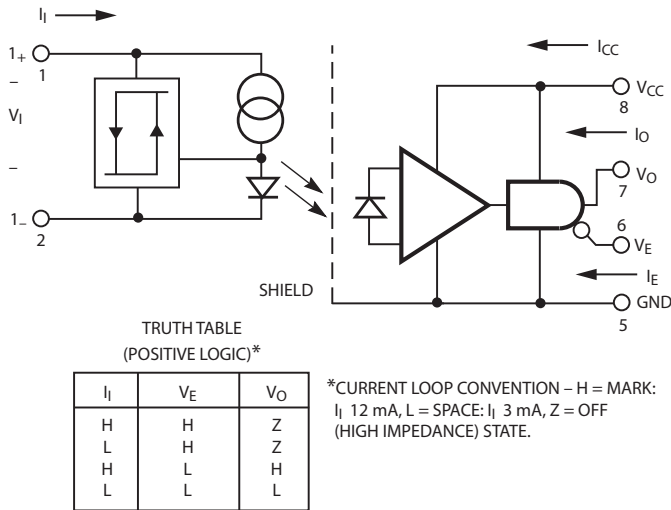

Figure 3. Block Diagram and Truth Table for HCPL-4200 Optocoupler.

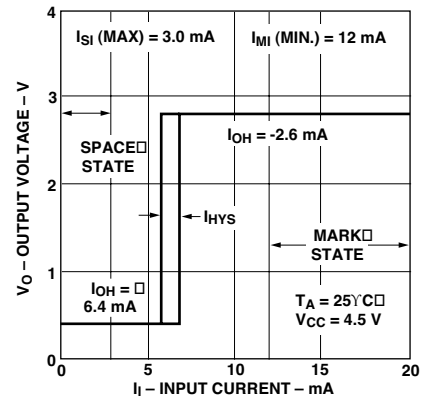

Figure 4. HCPL-4200 Typical Transfer Characteristic. Output Voltage vs. Input Loop Current.

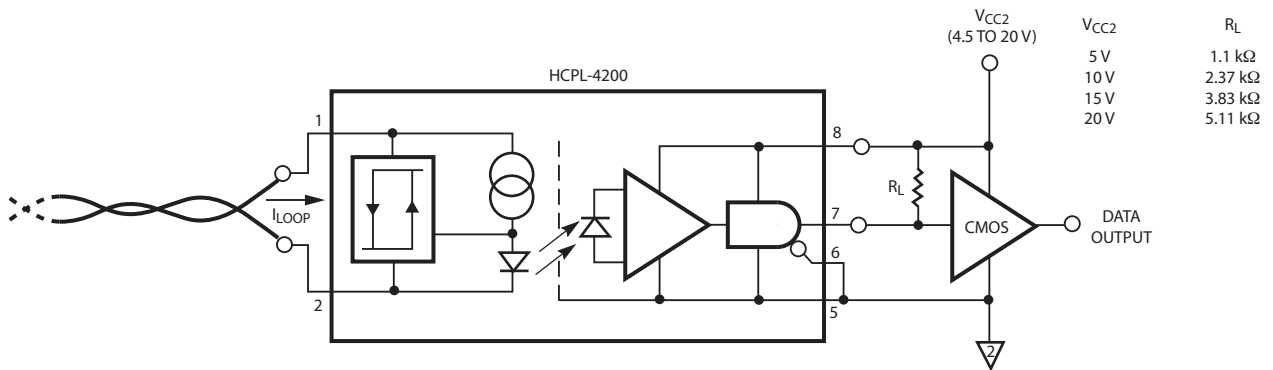

Figure 5. Recommended Interface from HCPL-4200 Receiver to CMOS Circuit.

Current Loop Configurations

Current loop configurations can be arranged in three basic ways: simplex, half duplex, and full duplex. Two variations within each configuration can exist, i.e., point-to-point or multidrop connections. Definitions for these terms, recommended interface circuits, performance trade-offs, and measured performance data are discussed and illustrated within this section.

Simplex

The most fundamental loop configuration is simplex point-to-point. The data flows in only one direction from the transmitter over the current loop to the remote receiver. This configuration is shown in Figures 6a and 6b.

Figure 6a illustrates a non-isolated, active current loop transmitter used with an isolated HCPL-4200 receiver. Figure 6b shows an isolated HCPL-4100 current loop transmitter used with a non-isolated, active receiver. A possible point-to-point application is to use a 20 mA current loop for communication between a computer and remote printer. The simplex topology can be expanded from point-to-point to multidrop. In a multidrop system, a number of receivers are in series on the loop containing only one transmitter as illustrated in Figure 6c. A configuration with multiple transmitters and one receiver is possible as well. However, the priority of the operating transmitter must then be established.

Undesired ground loops are eliminated and common mode rejection is increased by providing electrical isolation of the current loop. This isolation can be provided at either the receiver or transmitter end of the loop as illustrated in Figures 6a and 6b, respectively. The opposite end need not be isolated. The non-isolated unit supplies the current (active) for this simplex configuration. A circuit diagram of a non-isolated, active transmitter connected to the HCPL-4200 receiver (Figure 6a) is given in Figure 7. The data rate performance versus the length of the current loop for this circuit is given in Figure 8.

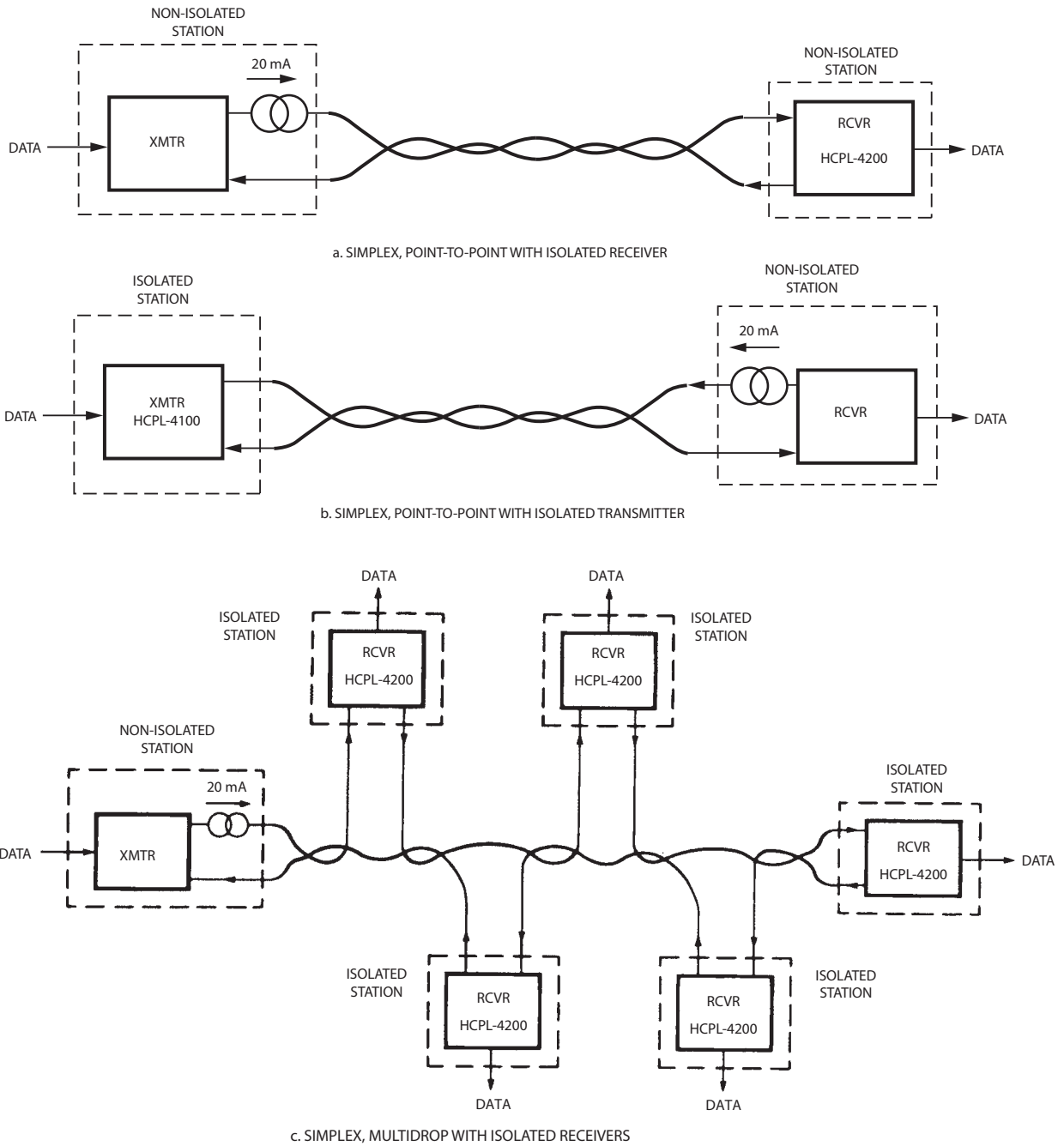

Figure 6. Simplex Current Loop Configurations: Point-to-Point with Current Source Located at: a. Transmitter, b. Receiver, c. Multidrop.

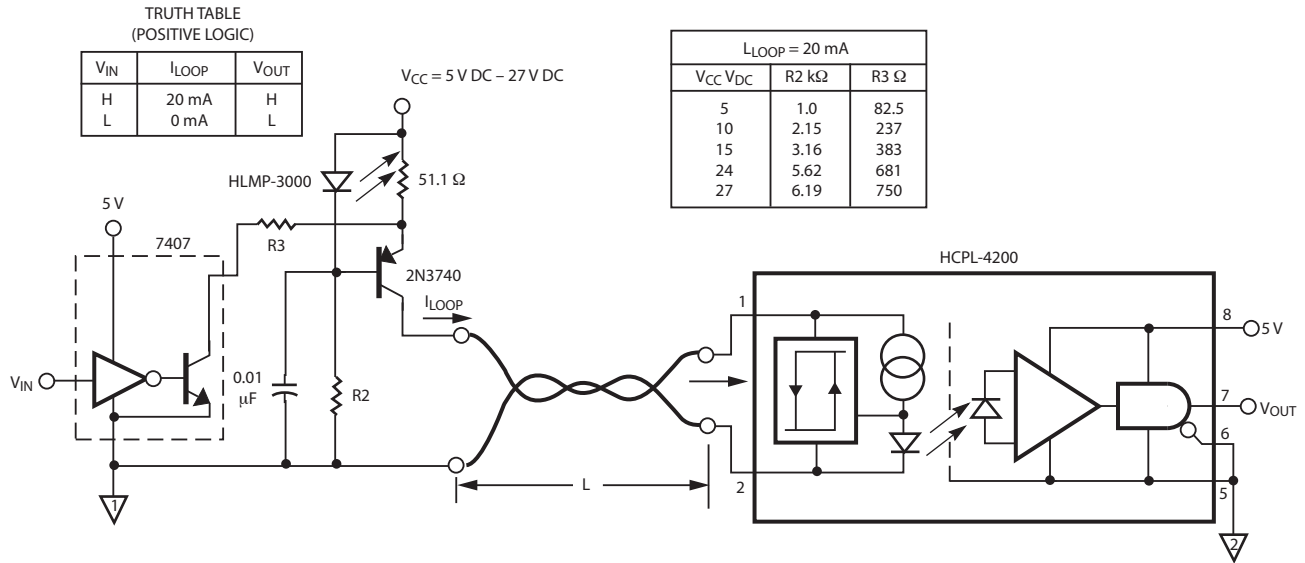

Figure 7. Recommended Non-Isolated Active Transmitter with HCPL-4200 Isolated Receiver for Simplex Point-to-Point 20 mA Current Loop.

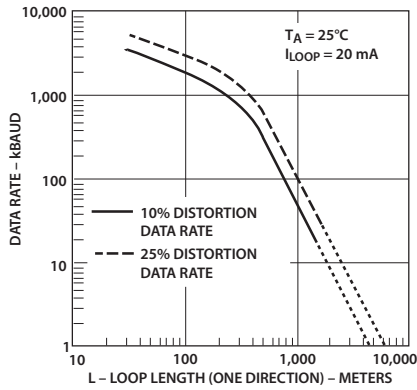

Figure 8. Typical Data Rate vs. Distance for Circuit of Figure 7.

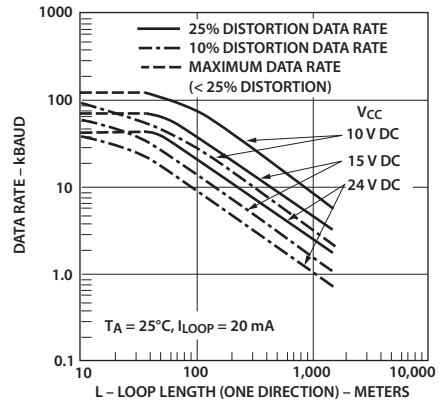

Figure 10. Typical Data Rate vs. Distance and Supply Voltage for Circuit of Figure 9.

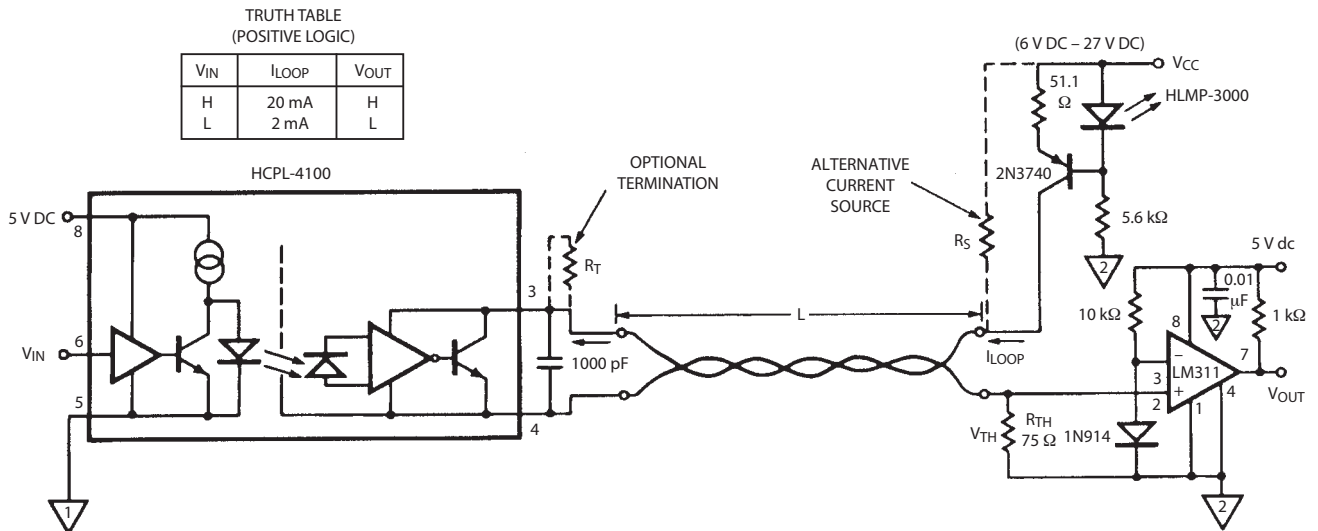

Figure 9. Recommended Non-Isolated Active Receiver with HCPL-4100 Isolated Transmitter for Simplex Point-to-Point 20 mA Current Loop.

The circuit for the alternate simplex arrangement of a non-isolated, active receiver connected to the HCPL-4100 transmitter is given in Figure 9. The trade-off of data rate versus loop length and compliance voltage is illustrated in Figure 10.

Comparing the data rate performance for each circuit shows that the active, non-isolated transmitter configuration is faster by a factor of 11 at 1000 meters (3281 ft.) of loop distance.

The design and location of the current source determine loop length and data rate performance. In both simplex configurations, the current source compliance voltage can be much lower than the HCPL-4100 device maximum of 27 V. However, limitation on the length of the loop (DC resistance) and data rate capability would dictate a minimum V_{CC} which can be used for the current source. With a $24\text{ V} \pm 10\%$ power supply, multidrop applications for very long loop lengths ($>3\text{ km}$) can be done. Device performance as a function of current source design is covered in a later section.

DC Performance

By summing the MARK state voltage drops around the current loop, a basic equation is derived for DC performance for the loop. This is expressed as the maximum distance over which a current loop can be operated.

$$L = \frac{V_{\text{COMP}} - \Sigma V_{\text{RCVR}} - \Sigma V_{\text{XMTR}}}{2 I_{\text{LOOP}} R_{\text{LINE}}} \quad (1)$$

Where

L = Length of wire in one direction

V_{COMP} = Compliance voltage of current source = $(V_{\text{CC}} - V_{\text{SAT}})$ ^[1]

(2)

V_{CC} = Supply voltage for current source

V_{SAT} = Saturation voltage of current source

I_{LOOP} = Operating loop current

R_{LINE} = DC resistance of wire per length

$\Sigma V_{\text{XMTR}}^{\text{MARK}}$ = Summation of voltage drops across each non-isolated and isolated transmitter current loop terminals when MARK state current flows.^[2]

$\Sigma V_{\text{RCVR}}^{\text{MARK}}$ = Summation of voltage drops across each non-isolated and isolated receiver current loop terminals when MARK state current flows.^[2]

Notes:

1. V_{COMP} must be less than the breakdown voltage rating of the transmitter unit in SPACE state.
2. The non-isolated unit supplies loop current. If two or more non-isolated units are used, then only one of these units needs to supply loop current.

This equation can be solved for any particular parameter of interest if the other remaining parameters are known. For example, Equations (1) and (2) can be solved for minimum power supply voltage, V_{CC} , which can be used for current source of Figure 7 for the following conditions.

Where,

$$V_{\text{COMP}} = \Sigma V_{\text{RCVR}}^{\text{MARK}} + \Sigma V_{\text{XMTR}}^{\text{MARK}} + 2L I_{\text{LOOP}} R_{\text{LINE}} \quad (3)$$

$\Sigma V_{\text{RCVR}}^{\text{MARK}} = 2.76\text{ V}$ (One isolated receiver)

$\Sigma V_{\text{XMTR}}^{\text{MARK}} = 0\text{ V}$ (Non-isolated transmitter voltage drop is incorporated in V_{COMP})

$I_{\text{LOOP}} = 22\text{ mA}$ (20 mA + 10%)

$R_{\text{LINE}} = 0.053\ \Omega/\text{m}$ (AWG No. 22)

$L = 305\text{ m}$

$$V_{\text{COMP}} = 2.76\text{ V} + 0\text{ V} + 2(305\text{ m})(0.022\text{ A})(0.053\ \Omega/\text{m}) = 3.47\text{ V}$$

and using equation (2)

$$V_{\text{CC}} = V_{\text{COMP}} + V_{\text{SAT}} \\ \text{where } V_{\text{SAT}} = 1.5\text{ V} \\ = 3.47\text{ V} + 1.5\text{ V}$$

$$V_{\text{CC}} = 4.97\text{ V}$$

For the listed conditions, these calculations are for the worst case temperature and unit to unit variations.

To address device voltage breakdown concerns, the current source compliance level for the current loop and the SPACE state current need to be known. The SPACE state current is determined by the transmitter when it is in the OFF state. The SPACE state current will not be necessarily equal to zero. Hence, when a current loop receiver is designed, the threshold must be set at a proper level to avoid detecting the SPACE state current as well as to provide a noise margin. With the HCPL-4200 receiver, SPACE state current of 3.0 mA or less is allowed. Should a larger noise current margin be desired for SPACE state, the maximum SPACE state current of the HCPL-4200 can be raised effectively by shunting the input with a resistor. Actual device current threshold does not change; only the loop current level required to reach SPACE state threshold increases. Use of a shunting resistor reduces the noise current margin in the MARK state for the HCPL-4200.

Should the HCPL-4100 transmitter be used, the maximum SPACE state current is 2.0 mA. For half duplex applications, a noise margin of 1.0 mA is specified for SPACE state with the combination of the HCPL-4100/4200 units.

AC Performance

The AC performance of a current loop is influenced by many factors. The typical data rate capability for the simplex configurations in Figures 7 and 9 are shown in Figures 8 and 10, respectively. The 10% (25%) distortion data rate is defined as the rate at which 10% (25%) distortion occurs to the output bit interval with respect to the reference input bit interval. This is expressed by equation (4).

$$f_D = \frac{1}{t_{BIT}} \tag{4}$$

Distortion Data Rate: where D = % distortion and t_{BIT} is bit time of the input signal when distortion is present in the output bit interval.

A square wave, as well as a 16-bit data stream, was used to “exercise” the current loop system. In both simplex point-to-point configurations, the input data rate was adjusted to result in a 10% (25%) distortion to the output signal for either an input square wave or a 16-bit pattern.

The 16-bit pattern was used to provide two propagation delay test conditions for the current loop. One part of the 16-bit waveform tests for data rate distortion affected by a long duration in either a MARK or SPACE state prior to state change. The other part of the 16-bit waveform tests for effects on data rate distortion via short durations in either a MARK or SPACE state prior to a state change. In both simplex configurations in Figures 7 and 9, the transition from either a short or a long duration MARK state to a SPACE state affects the data rate distortion the most. The 16-bit exerciser circuit diagram and bit stream waveform are shown in Appendix A.

In the description of the AC performance that follows, an approximation has been made to simplify the analysis. The transmission line is treated as a lumped capacitance. A more complete analysis of AC performance would require rigorous treatment via transmission line theory.

Non-isolated Active Transmitter with the HCPL-4200 Receiver

The typical waveforms for the non-isolated active transmitter used with the HCPL-4200 (Figure 11) are shown in Figures 12 and 13. The loop length is 305 meters (1000 ft.). Figure 12 shows 10% distortion when the input signal is a 16-bit pattern. The total propagation delay shown in Figure 12 for a SPACE to MARK transition is 2.4 μ s. The propagation delay of the transmitter and receiver is 0.3 μ s. Hence, the propagation delay for the transmission line is 2.1 μ s. Current and voltage waveforms for the current loop at the receiver end are shown in Figure 13 for a 10% distortion of data to an input square wave. Notice the loop current waveform delay of 2.4 μ s before V_O follows V_{IN} . The important parameter to observe is loop current. When the loop current level exceeds the HCPL-4200 current threshold, V_O changes state. Loop voltage at the receiver only follows the current level and changes by approximately one volt. This simplex configuration provides the best speed performance.

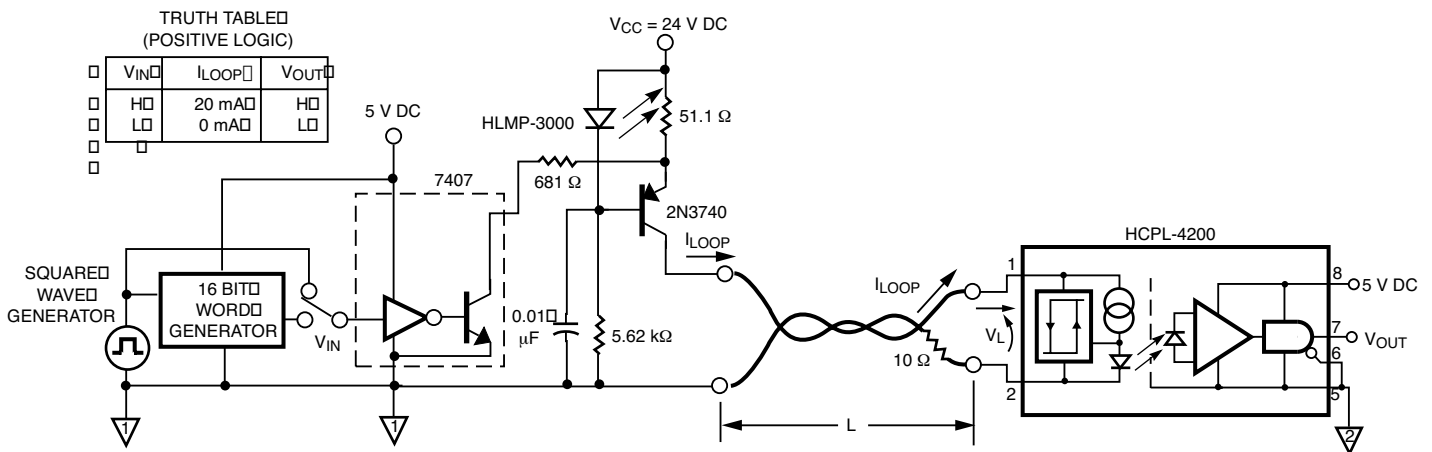

Figure 11. Data Rate Test Circuit for Non-Isolated Active Transmitter to Isolated HCPL-4200 Receiver.

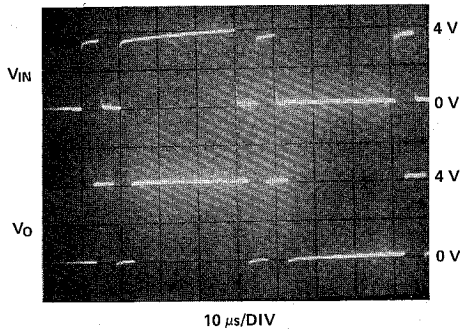

Figure 12. Timing Comparison of Output Signal (V_o) to Input Signal (V_{IN}) using 16-bit Word at 10% Distortion with 305 m (1000 ft.) Loop Distance. Reference Figure 11.

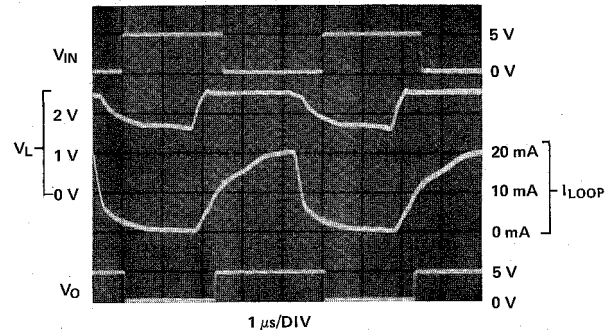

Figure 13. Characteristic Waveform Performance of Circuit in Figure 11 with 305 m (1000 ft.) Loop Distance, Square Wave Input and Output Distortion of 10%. a. Input Voltage (V_{IN}), b. Receiver Load Voltage (V_L), c. Loop Current (I_{LOOP}), d. Output Voltage (V_o).

Non-Isolated Active Receiver with the HCPL-4100 Transmitter

The typical waveforms for the non-isolated active receiver used with the HCPL-4100 (Figure 14) are shown in Figures 15 and 16. The loop length is 305 meters (1000 ft.). Figure 15 shows 10% distortion when the input signal is a 16-bit pattern. Figure 16 illustrates a 10% distortion for an input square wave. Recall that current level, not voltage level, determines the switching point.

At the input low-to-high state change, the loop current changes momentarily to the MARK state short circuit output current level, I_{SC} (typically 85 mA). A current spike appears at the receiver end after the inherent transmission line propagation delay of approximately 2 μ s, as expanded in Figure 17. The spike is caused by a sudden discharge of cable capacitance. However, the loop current rapidly decreases from the I_{SC} level to a 20 mA level when the line discharge is complete. The time duration of I_{SC} can be calculated by referring to the output power dissipation calculations for the HCPL-4100 in Appendix B.

The non-isolated receiver switched states when the loop current crossed approximately at the 10 mA level. Yet, the loop voltage took approximately 10 μ s to change from a current source voltage compliance level of 22.5 V to a MARK state voltage of 2.4 V at 20 mA. This loop voltage characteristic does not limit the turn-on speed performance.

At the input signal high-to-low transition, the HCPL-4100 transmitter turns off after the device propagation delay. However, the loop current at the receiver does not change from 20 mA until approximately 30 μ s later. This is due to the current source charging the line capacitance at a fixed rate of 20 mA from essentially a MARK state voltage level (2.4 V) to the compliance level of the current source. Only after the compliance voltage is reached does the loop current fall below the 10 mA threshold of the receiver. As before, the current level at the receiver determines the switching time. In this example, the compliance voltage of the current source influences the turn-off delay of the loop. This dependence is graphically illustrated in Figure 10.

General Factors Affecting Data Rate

The three factors that limit data rate and their corresponding trade-offs are loop length, current source, and device performance.

1. Loop length: The length of the line limits the speed performance of a current loop. This results mainly from the total capacitive loading effect of the cable upon the transmitter and receiver. The data rate versus length of line for the two simplex point-to-point configurations are illustrated in Figures 8 and 10. Shielded cable provides more noise immunity but, in general, the capacitance per unit length is larger than unshielded cable. The characteristics of the cable, such as wire size, twist, insulation material, etc., all influence the maximum data rate. (The characteristics of the cable used in the text applications are listed in Appendix C.)

2. Current source: The location, type, and compliance voltage of the current source used within a current loop can affect the system data rate. The primary limitation on data rate is the location of the current source

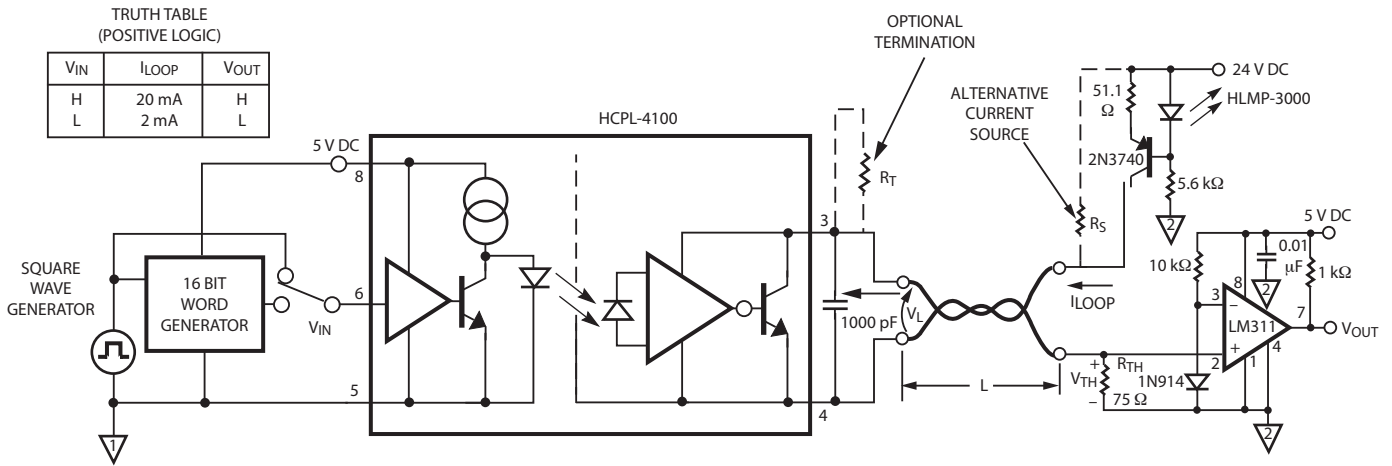

Figure 14. Data Rate Test Circuit for Isolated HCPL-4100 Transmitter to Non-Isolated Active Receiver.

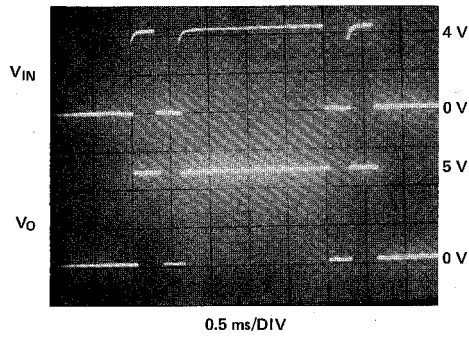

Figure 15. Timing Comparison of Output Signal (V_o) to Input Signal (V_{in}) Using 16-bit Word at 10% Distortion with 305 m (1000 ft.) Loop Distance. Reference Figure 14.

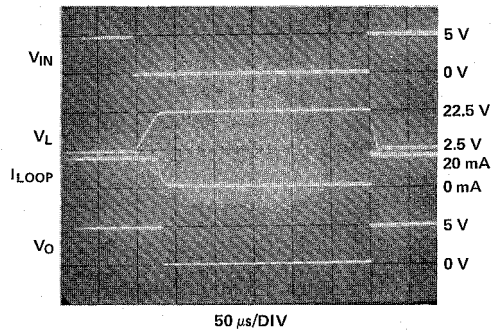

Figure 16. Characteristic Waveform Performance of Circuit in Figure 14 with 305 m (1000 ft.) Loop Distance, Square Wave Input and Output Distortion of 10%. a. Input Voltage (V_{in}), b. Transmitter Load Voltage (V_L), c. Loop Current (I_{loop}), d. Output Voltage (V_o).

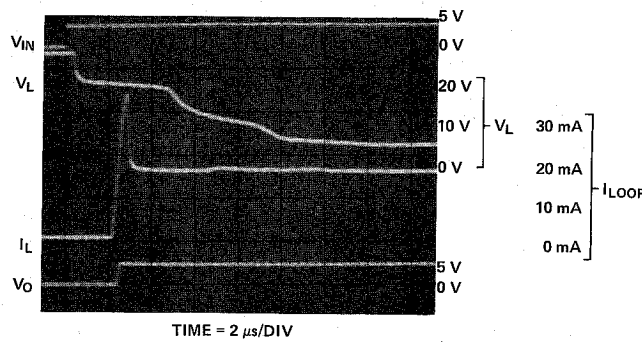

Figure 17. Expanded Waveform Response of Figure 16. Displayed are details of I_{sc} Magnitude and Duration at Receiver as well as Transmitter Output Voltage (V_L).

within the loop. When the current source is located at the transmitter end of the loop rather than at the receiver end, the maximum data rate is much higher for a given loop length. This effect can be seen when comparing data in Figures 8 to 10. The main reason for the lower data rate capability shown in Figure 10 is that the current source must charge the cable capacitance to the compliance voltage of the current source. The speed achieved in Figure 8 is the result of small cable voltage changes between the MARK and SPACE states. Practical applications of the HCPL-4100 and HCPL-4200 optocouplers generally require the current source to be located at the non-isolated end of the loop. For best speed performance, an active non-isolated transmitter should be used with the HCPL-4200 receiver. However, in full duplex applications (two simplex loops), the non-isolated ends should be at a common location. Hence, overall bidirectional system data rates are limited by the slowest loop, i.e., the one which contains a non-isolated, active receiver. More discussion of full and half duplex applications is found in subsequent sections.

The type of current source can affect speed performance. A simple resistor, when used with a voltage source at the non-isolated loop end, can set the loop current level. Improper source impedance or termination of the loop causes reflections which distort data resulting in a lower data rate capability. Termination of a current loop with an impedance equivalent to the characteristic impedance of the line can improve the data rate capability by approximately 20%. Termination resistance does reduce part of the voltage available for operating station(s) on the loop.

An active element current source can be controlled by current steering which allows for a higher speed of

operation while providing consistently high on and off output impedance. Less variation in current source output impedance can help to reduce multiple signal reflections from occurring. Active element current sources are described in the *Current Sources* section of this application note.

The compliance voltage can influence the speed performance of the non-isolated, active receiver circuit shown in Figure 9. Data rate dependency upon the compliance voltage is shown in Figure 10. Reducing the current source supply voltage from 24 V DC to 10 V DC for a simplex point-to-point current loop configuration increases the data rate by a factor of 3.5 in a 1000 meter (3281 ft.) loop. The reason for the improvement is that less time is required to charge the transmission line to the lower compliance voltage level at a constant charge rate. However, the opposite simplex arrangement of a non-isolated, active transmitter like that in Figure 7 has no data rate dependency on compliance voltage, as illustrated in Figure 8. This is the result of the HCPL-4200 performing current threshold detection, not voltage level detection.

The maximum usable data rate for a given loop length and configuration is usually determined by the propagation delay differences of the current loop and the amount of skew that is allowed in the user's application. Propagation delay skew is $|t_{PLH} - t_{PHL}|$. Factors which contribute to the system propagation delay skew are the current source compliance voltage level, the current source location, the inherent propagation delay skew of the current source, as well as the optocoupler propagation delay skew. Detailed information on factors which affect distortion of data are discussed in the subsequent *Half Duplex* section.

3. Device performance: The propagation delay of the transmitter and the receiver can influence data rates for short loop lengths (<100 meters) in high speed applications (>1 MBd). Generally, current loops are designed to operate over much greater distances than 100 meters. Consequently, the cable capacitance dominates the data rate limitations.

Another device performance consideration is the power dissipated in the HCPL-4100 transmitter. An example of a power dissipation calculation for the HCPL-4100 is given in Appendix B. Derating may be required when operating the unit at a large V_{CC} voltage.

Optional Device Protection Considerations
Specific end-product applications may require additional device protection. A bridge rectifier can be included in order to remove loop polarity connection concerns. Current buffering can be designed for loop currents greater than 30 mA. The possibility of damage due to electrostatic discharge to the cable or interconnection points can be significantly reduced by the use of energy absorbing devices, such as TransZorbs® or metal oxide varistors (MOV).

Full Duplex

A common and useful extension of the simplex configuration is the full duplex configuration. Full duplex communication is defined as the simultaneous, bidirectional transmission of information between local and remote units. The block diagram in Figure 18 shows this point-to-point configuration.

Essentially, a full duplex arrangement is two point-to-point simplex loops (a four wire system) used simultaneously for back and forth data flow. A common current loop application for full duplex configuration is connecting remote terminals to an I/O interface section of a central computer system.

Implementation of optical isolation within a full duplex current loop system should be done at one common end of the loops. Two separate, active, non-isolated units are located at the other end of the loops. Figure 18 illustrates this. Providing isolation at one common end significantly reduces common mode coupling between the two loops. In most cases, the full duplex data rate is limited by the loop containing the HCPL-4100 and the non-isolated active receiver. This limitation can be circumvented by using an isolated current source at the HCPL-4100 end of the loop and a non-isolated passive receiver. The isolated current source increases the cost of the data link, but this increased cost may be justified by the speed improvement obtained. All information described in the *Simplex* section for the performance of a simplex point-to-point current loop configuration applies to full duplex applications as well.

Half Duplex

A half duplex current loop provides non-simultaneous, bidirectional data flow between remote and local equipment. This configuration utilizes a simpler two wire interconnection compared to the four wire arrangement of the full duplex case. The half duplex system can easily be expanded from a point-to-point application to a multi-drop application with multiple transmit and receive stations along the loop. The block diagrams of Figure 19 demonstrate the two cases of point-to-point and multidrop for half duplex.

A characteristic of the half duplex configuration is the need to establish priority of transmitters in the current loop whether the loop is point-to-point or multidrop. Protocol in the information being transferred ensures that only one transmitter is sending data at any given time. Typical usage of a half duplex current loop parallels similar applications for the full duplex case.

DC Performance

As Figure 19 illustrates, isolation of the current loop from logic systems is easily implemented at one end of the loop by the use of the combination of the HCPL-4100 transmitter and the HCPL-4200 receiver. Significant reduction of common mode influences on the current loop, elimination of ground potential differences, and specified loop current noise immunity are achieved by the use of these complementary optocouplers. For this combination of optocouplers, the loop current noise immunity is a minimum of 1 mA in the SPACE state and 8 mA in the MARK state. A non-isolated active transceiver (transmitter and receiver) with one current source operates at the opposite end of the current loop.

The maximum compliance voltage of the current source is limited by the breakdown voltage capability of any transmitter in the half duplex loop. The isolated HCPL-4100 transmitter has a maximum operat-

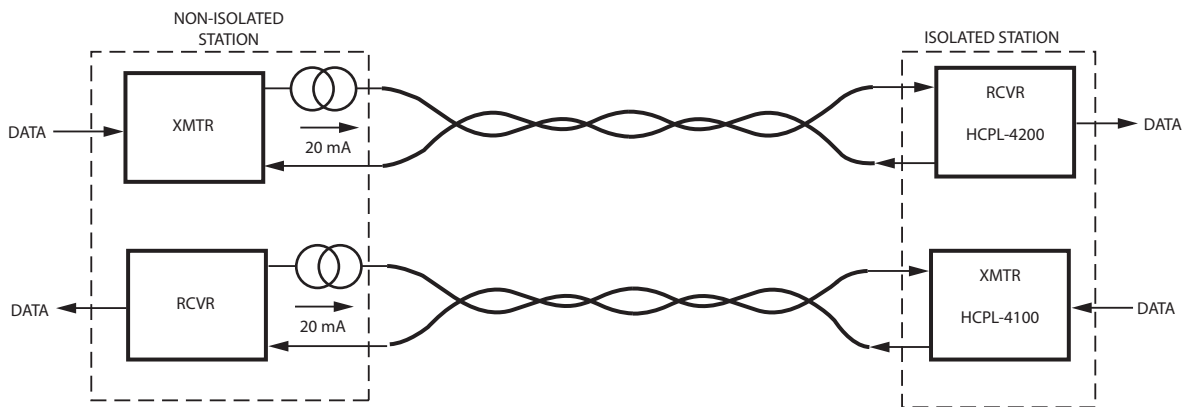

Figure 18. Full Duplex Point-to-Point Current Loop System Configuration.

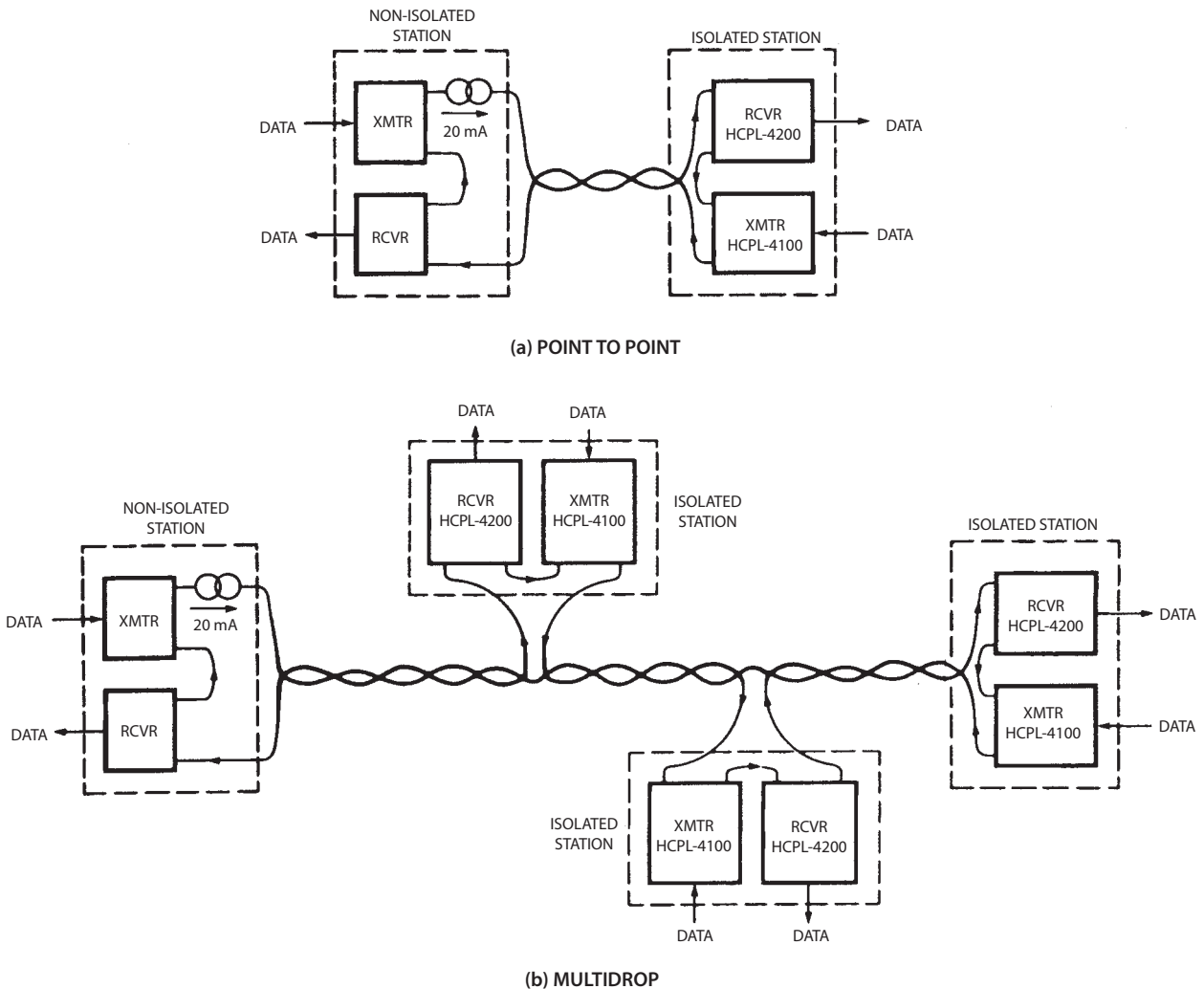

Figure 19. Half Duplex Current Loop System Configurations for Point-to-Point and Multidrop.

ing voltage of 27 V DC. However, in multidrop applications, each isolated HCPL-4200 receiver shares a portion of the compliance voltage during the SPACE state, worst case 0.9 V DC at a minimum SPACE state current of 0.5 mA. Also, each isolated conducting HCPL-4100 transmitter shares a portion of the compliance voltage during SPACE state as well. Worst case, this is 0.95 V DC at 0.5 mA. For example, with four pairs of HCPL-4100 and HCPL-4200 units being used, an additional worst case 6.5 V DC can be added to increase the maximum compliance voltage value from 27 to 33.5 V DC for the

current source. The additional 6.5 V DC is calculated on the basis of one of the HCPL-4100 transmitters interrupting 22 mA loop current at 200 meter station intervals. This increase in the compliance voltage level allows another isolated station to be used. Minimum V_{CC} required for the current source of Figure 20(b) with five isolated stations in the MARK condition with worst case parameters previously used yields 33.2 V DC. A higher compliance voltage can allow longer loop lengths, but the data rate will be slower. Precautions must be taken to prevent the removal of any stations from the

loop in order to avoid an excessive compliance voltage from overstressing any transmitter remaining in the loop. A design compromise has to be determined for the benefits achieved at different compliance voltages. Equation (1) from the *Simplex* section can be used to determine any DC parameter in a half duplex application.

A specific active, non-isolated transceiver which can be used in point-to-point and multidrop applications with the HCPL-4100 and HCPL-4200 current loop optocouplers is shown in Figure 20.

AC Performance

Point-to-Point

The corresponding data rate performance versus loop distance and direction of data is given in Figure 21 for the half duplex point-to-point application. Definitions for 10% and 25% distortion data rates are given in the *Simplex Configuration* section.

Transmission of data from an isolated T/R (transmitter and receiver pair) to an active non-isolated T/R limits the half duplex data rate performance. This limitation is due to the slower speed of a current loop when using

an isolated transmitter. A lower current source compliance voltage improves the data rate of an isolated T/R to a non-isolated T/R as discussed in the *Simplex* section.

Multidrop

The data rate performance for half duplex multidrop applications, as illustrated in Figure 20(b), is summarized in Tables 1 and 2. These tables compare data rate versus the loop distance between stations, total length of loop, direction of data, distortion data rate, and data format. Table 1 illustrates at fixed distortion (10% or 25%) how the data rate

can be different at different stations along the loop. Table 2 shows the pulse width distortion that results when the multidrop loop is operated at several fixed data rates.

Comparison of data rates for point-to-point (half duplex) and multidrop configurations can appear contradictory. Data presented in Figure 21 and Table 1 illustrate this at a 25% distortion on a 915 m (3000 ft.) loop. A comparison shows the influence of multiple stations upon the data rate for a fixed loop length. In the point-to-point case, the data rate is 62.5 kbd from an active, non-isolated

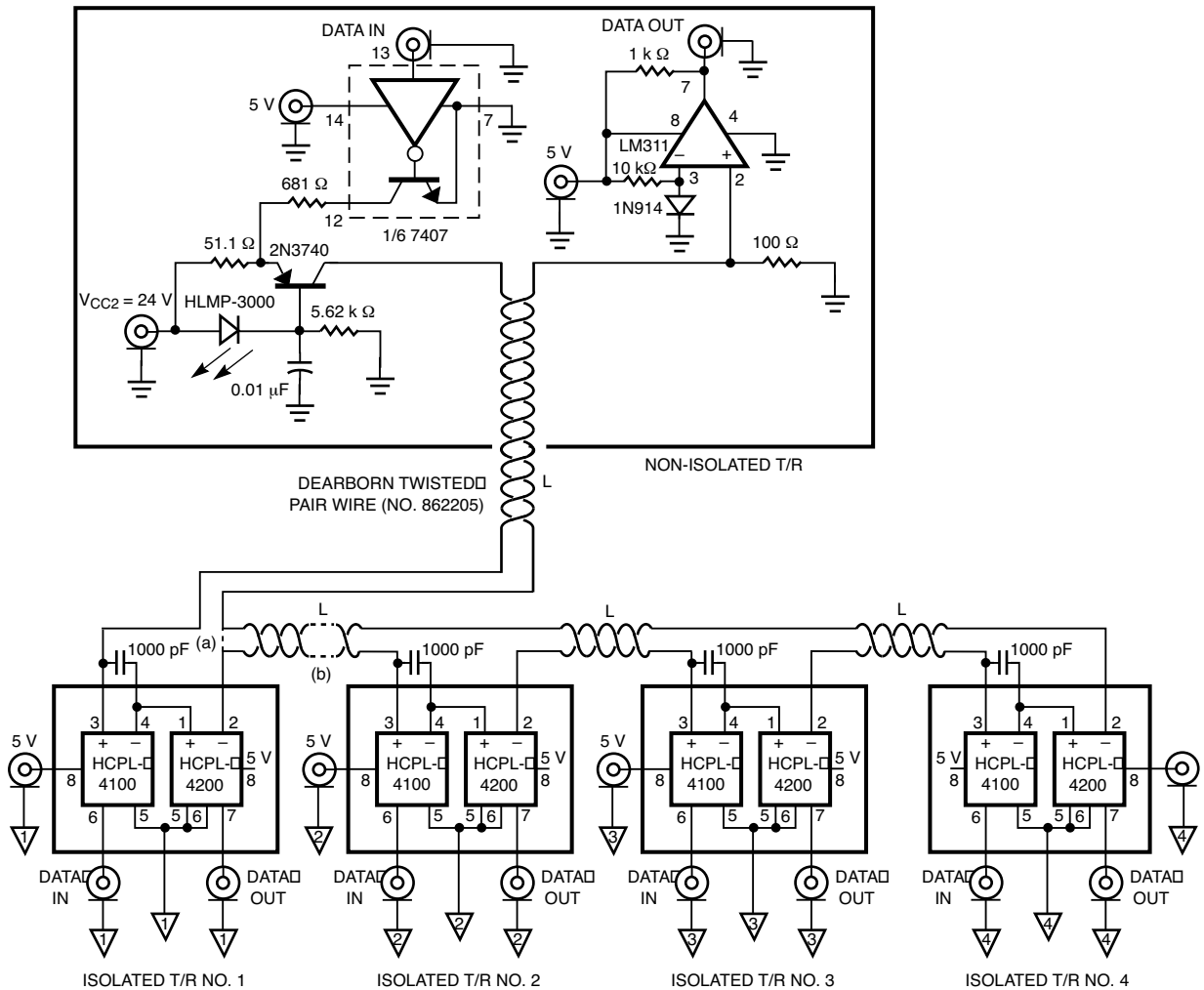

Figure 20. Circuit Schematic of Half Duplex Point-to-Point and Multidrop Configurations.

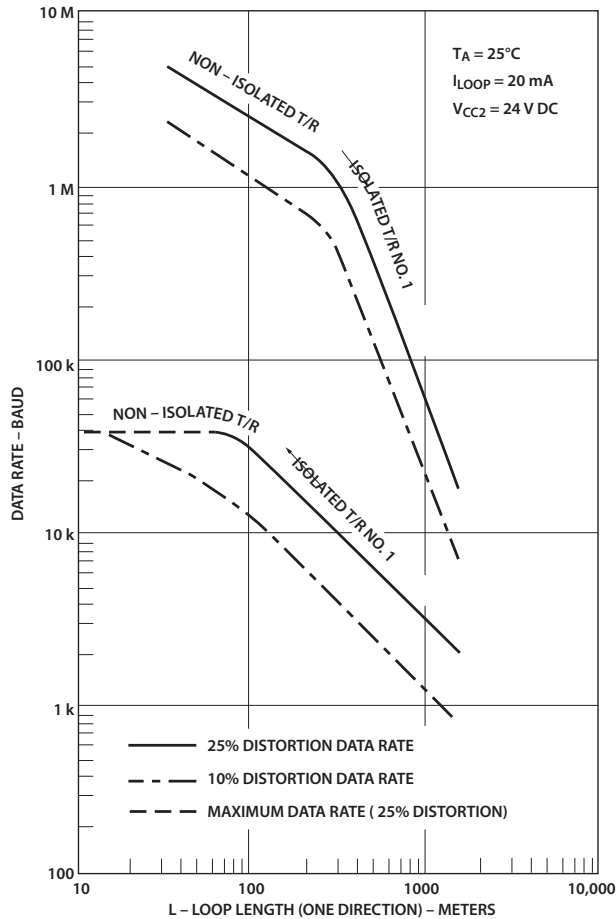

Figure 21. Half Duplex Point-to-Point (Figure 20a) Data Rate vs. Loop Length and Data Direction.

T/R to the isolated T/R No. 1. In the multidrop case, non-isolated T/R to the isolated T/R No. 3, data rate in the same direction is 25 kBd. As expected, the data rate in point-to-point is faster because the current source only needs to charge the line to a lower sum ($\approx 1/2$) of MARK state voltages than in the multiple station case. However, in the opposite direction of isolated T/R No. 1 to active, non-isolated T/R, the point-to-point data rate is 3.33 kBd while the multidrop data rate is 6.25 kBd. In this instance, multidrop is twice as fast as the point-to-point case over the same distance, contrary to “expected” results. The reason for this speed improvement results from the fact that when T/R No. 3 interrupts

the loop current, the current source continues to charge the loop until the compliance voltage is reached causing the current source to shut down. Fortunately, the voltage difference between the sum of all MARK state voltage drops and compliance voltage is small due to the total of four stations in the loop. Hence, a small voltage excursion requires considerably less charging time than if this charging occurred over a larger voltage excursion.

In addition, with the usage of multiple stations at a constant data rate, the data distortion can vary from station to station. This distortion varies with respect to the transmitting station. As an illustration from Table 2,

the 915 m (3000 ft.) example with three remote stations [i.e., the isolated T/R No. 3 transmitting at 6.25 kBd to successive 305 m (1000 ft.) stations of T/R No. 2, T/R No. 1, and an active non-isolated transceiver] yields distortion levels of 19%, 31%, and 25%, respectively. Larger distortion at an interim station than at a station located at the end of a loop is due to different thresholds for each station. Identical current threshold levels at each station provide progressively increasing distortion levels at each station along the loop. Also, reflection of signals between stations can account for inconsistent distortion levels at various stations on a loop system. The designer is limited to a data rate that results in an acceptable distortion for each station.

In general, data rate limitations in multidrop applications for data which flows from active non-isolated station to isolated stations is caused by the propagation delay time of the line and the charging or discharging time for the total line capacitance. Charging and discharging the line occurs over a voltage level which is equal to the difference between the sum of all MARK state voltages and the sum of all SPACE state voltages which are presented at the active non-isolated loop connection points. Data rate limitations in the opposite direction (isolated units to an active, non-isolated unit) are limited by the propagation delay time of the line and by the time to charge total line capacitance over a voltage equal to the difference between the sum of the MARK state voltages and the compliance voltage of the current source.

Table 1. Constant % Distortion, Variable Data Rate for Half Duplex Multidrop Configuration.

Data In	Data Out	L Length between Data Input and Data Output Points		L _T Total Loop Length m (ft.)	Data Rate kBd	% Distortion	Comments
		m	ft.				
Active Non-Isolated Transceiver	T/R #4	122	400	122 (400)	250	25%	Input Signal: Square Wave Current Source: 20 mA/24 V DC Half Duplex Current Loop Curcuit Schematic: Figure 20b
	T/R #3	92	300		370		
	T/R #2	61	200		370		
	T/R #1	31	100		250		
	T/R #4	122	400		125	10%	
	T/R #3	92	300		167		
	T/R #2	61	200		167		
	T/R #1	31	100		125		
Isolated T/R #4	Non-Iso. T/R	122	400	122 (400)	62.5	25%	Curcuit Schematic: Figure 20b
	T/R #1	92	300		62.5		
	T/R #2	61	200		82.5		
	T/R #3	31	100		100		
	Non-Iso. T/R	122	400		25	10%	
	T/R #1	92	300		25		
	T/R #2	61	200		33.3		
	T/R #3	31	100		40		
Active Non-Isolated Transceiver	T/R #3	915	3000	915 (3000)	25	25%	
	T/R #2	610	2000		33.3		
	T/R #1	305	1000		25		
	T/R #3	915	3000		12.5	10%	
	T/R #2	610	2000		16.7		
	T/R #1	305	1000		12.5		
Isolated T/R #3	Non-Iso. T/R	915	3000	915 (3000)	6.25	25%	
	T/R #1	610	2000		5.0		
	T/R #2	305	1000		8.25		
	Non-Iso. T/R	915	3000		2.0	10%	
	T/R #1	610	2000		2.0		
	T/R #2	305	1000		3.33		

Table 2. Constant Data Rate, Variable % Distortion for Half Duplex Multidrop Configuration.

Data In	Data Out	L Length between Data Input and Data Output Points		L _T Total Loop Length m (ft.)	Data Rate kBd	% Distortion	Comments
		m	ft.				
Active Non-Isolated Transceiver	T/R #4	122	400	122 (400)	250	25%	Input Signal: Square Wave Current Source: 20 mA/24 V DC Half Duplex Current Loop
	T/R #3	92	300		250	30%	
	T/R #2	61	200		250	15%	
	T/R #1	31	100		250	25%	
	T/R #4	122	400		125	10%	
	T/R #3	92	300		125	6%	
	T/R #2	61	200		125	7.5%	
	T/R #1	31	100		125	12%	
Isolated T/R #4	Non-Iso. T/R	122	400	915 (3000)	62.5	25%	Curcuit Schematic: Figure 20b
	T/R #1	92	300		62.5	25%	
	T/R #2	61	200		62.5	19%	
	T/R #3	31	100		62.5	6%	
	Non-Iso. T/R	122	400		25	10%	
	T/R #1	92	300		25	10%	
	T/R #2	61	200		25	7.5%	
	T/R #3	31	100		25	7.5%	
Active Non-Isolated Transceiver	T/R #3	915	3000	915 (3000)	25	25%	
	T/R #2	610	2000		25	17.5%	
	T/R #1	305	1000		25	25%	
	T/R #3	915	3000		12.5	10%	
	T/R #2	610	2000		12.5	7.5%	
	T/R #1	305	1000		12.5	12%	
Isolated T/R #3	Non-Iso. T/R	915	3000	915 (3000)	6.25	25%	
	T/R #1	610	2000		6.25	31%	
	T/R #2	305	1000		6.25	19%	
	Non-Iso. T/R	915	3000		2.0	10%	
	T/R #1	610	2000		2.0	8%	
	T/R #2	305	1000		2.0	12%	

Current Sources

Resistor

Current sources used for current loop systems can vary in performance, complexity, and cost. The most elementary and inexpensive technique for supplying loop current is to use a series resistor between the non-isolated station power supply and the loop. The resistance value (R_S) to use is a function of the desired loop current (I_{LOOP}), of the type of cable (resistance per length, R_{LINE}), the loop length (L), the number of stations on the loop with their respective MARK state terminal voltages (ΣV_{MARK}) and the power supply voltage (V_{CC}) for the non-isolated station. Equation (5) determines the resistor value. The simplicity of a single resistor yielding a 20 mA loop current is achieved at the expense of requiring that the loop configuration cannot be changed without changing the resistor value.

$$R_S = \frac{V_{CC} - (I_{LOOP}) (R_{LINE})2L - \Sigma V_{MARK}}{I_{LOOP}} \quad (5)$$

Speed performance of a loop system using a current setting resistor is slower than with an active current source. This difference arises from an exponential current response versus a linear current response associated with an active current source. For a given current threshold level, the linear response charges a capacitive line quicker than an exponential response. When a current setting resistor is used, termination resistance can be employed at the isolated stations in order to somewhat reduce the signal reflections along a loop. Up to a 20% speed improvement can be obtained with termination resistance equal to characteristic line impedance. However, with the use of termination resistance, allowance

must be made for the additional MARK state voltage drop of the terminating resistor with respect to the available compliance range of the current loop.

LED/Transistor

The recommended current source is a simple, relatively inexpensive, active constant current source shown in Figure 22. The LED provides a stable voltage reference (V_F) for the transistor base and also helps to compensate the base-emitter junction voltage (V_{BE}) changes with temperature. This current source is fairly independent of the V_{CC} level if the LED bias current (I_F) is set so that the V_F only changes slightly with large variations in I_F (≈ 60 mV/decade of I_F). Regulation of 10% in output current can easily be achieved over a V_{CC} range of 5 – 27 V DC.

When large V_{CC} is used with low MARK state voltage conditions, the use of a transistor with good thermal

conduction to the ambient environment minimizes the variation in the source current because of the variation of V_{BE} with temperature. This state is the large power dissipation condition.

This current source can be easily current steered for fast switching. Current steering is illustrated in Figure 7. For applications of this current source at high data rates over short loop distances, it is important that the difference in propagation delays from on-to-off and off-to-on be made as small as possible. Status indication is conveniently given by the LED.

Specialized Integrated Circuits

More complicated current sources usable in current loops are current mirrors or specialized integrated circuits. The current mirror displayed in Figure 23 requires the use of a matched pair of transistors in order to perform well.

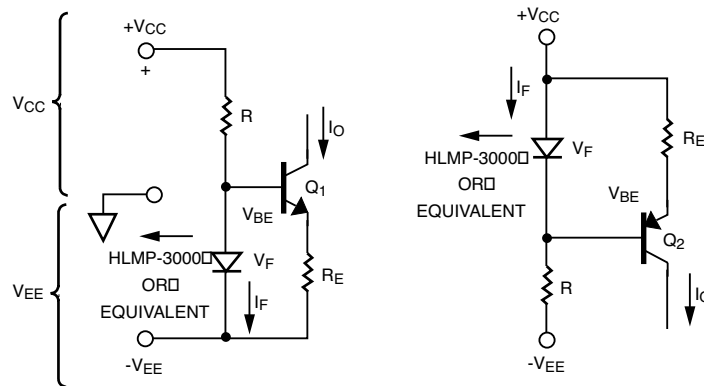

$$R = \frac{V_{CC} + V_{EE} - V_F}{1 \text{ mA}}$$

$$I_O = \frac{V_F - V_{BE}}{R_E}$$

$$V_F = 1.5 \text{ V AT } I_F = 1 \text{ mA}$$

$$P = \text{POWER IN } Q_1 \text{ OR } Q_2 \\ = I_O (V_{CC} - I_O R_E - \Sigma V_{MARK})$$

Figure 22. Recommended Constant Current Source.

In general, commercially available matched pairs are not designed for output collector currents greater than 10 mA. Additional components which are needed to obtain 20 mA results in greater complexity and higher cost with less reliability. In order to reduce power supply noise influences and improve thermal stability, significant transistor emitter degeneration resistance must be used. This degeneration sacrifices the available voltage range between

the total MARK state voltage and the compliance voltage of the current mirror.

In Figure 23(c), the LM234 integrated circuit current source can be used. More components are required for temperature compensation to provide a proper current level and regulation over a wide temperature range as well as to prevent possible oscillations of this active device. In addition, the switching character-

istics of the LM234 must be considered with regard to the desired loop speed performance. Over all, the current source provides good regulation ($\pm 3\%$) for current loop usage, but the cost of additional components and space in an input-output module may detract from the design convenience of this device.

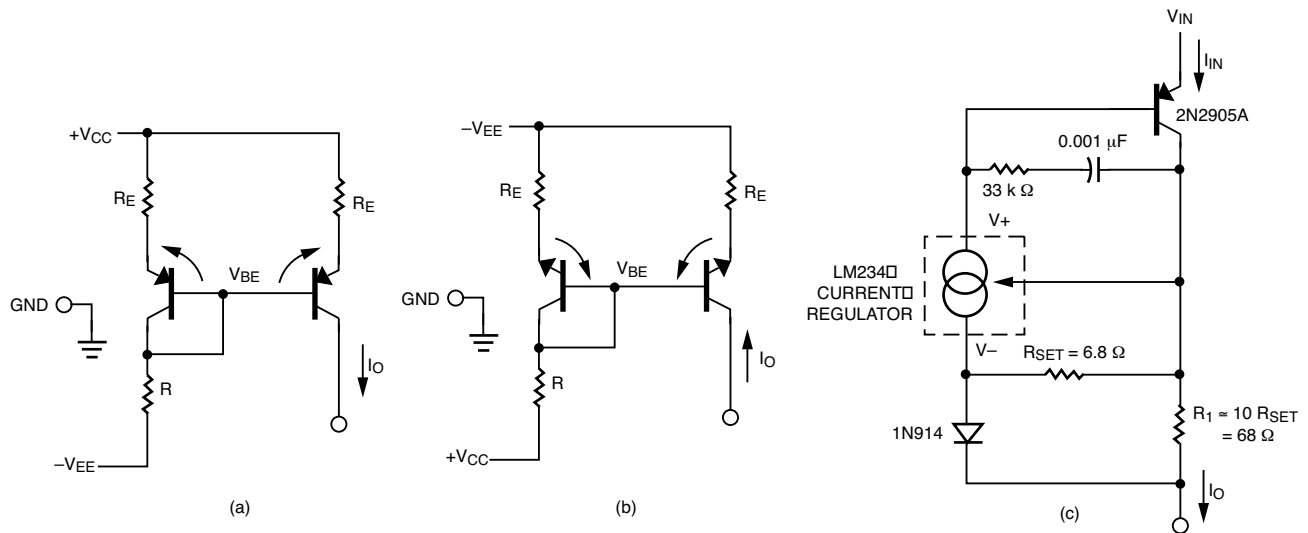

$$R_E = \frac{\Delta T (\Delta V_{BE}/\Delta T)}{\Delta I} ; \begin{cases} \Delta T = \text{TEMPERATURE CHANGE FROM ROOM TEMPERATURE IN } ^\circ\text{C} \\ \Delta I = \text{ACCEPTABLE DEVIATION FROM } I_O \text{ IN mA} \\ \frac{\Delta V_{BE}}{\Delta T} = \frac{\Delta V_{BE2} - \Delta V_{BE1}}{\Delta T} \end{cases}$$

$$I_O = \frac{V_{CC} + V_{EE} - V_{BE}}{R + R_E}$$

Figure 23. Specialized Integrated Circuit Current Sources. Current Mirrors: a. PNP, b. NPN. Current Regulator: c. LM234 plus Components

Appendix A

16-Bit TTL Data Exerciser Circuit

The purpose of this circuit is to provide long (6 bits) and short (1 bit) durations of the logic one and logic zero states in different time sequences. Figure 24 illustrates the 16-bit TTL output waveform (Q_A).

Appendix B

HCPL-4100 Power Dissipation Calculations

The power dissipation calculation for the HCPL-4100 transmitter is made using the standard method for determining the input power dissipation. Calculation of the output power dissipation must take into account power consumed in three different operating conditions. These conditions are: power dissipated during transition from SPACE to MARK state, power dissipated in MARK state, and power dissipated in SPACE state. The worst case average power dissipated over two bit

intervals should be calculated. The average output power dissipation is calculated from the following formula:

$$P_O = \frac{P_{SM}t_{SM} + P_Mt_M + P_S t_S}{2 t_{BIT}} \quad (6)$$

$$= \frac{I_{SC} (V_{COMP} + V_{MO})}{2} \quad (7)$$

where

P_O = Average output power dissipated during a worst case time interval

P_{SM} = Power dissipated during SPACE to MARK transition

I_{SC} = MARK state short circuit output current

V_{COMP} = Compliance voltage of current source

V_{MO} = MARK state output voltage

P_M = Power dissipated during MARK state

$$= V_{MO} I_{LOOP} \quad (8)$$

I_{LOOP} = Loop Current

P_S = Power dissipated during SPACE state

$$= V_{COMP} I_{SO} \quad (9)$$

I_{SO} = SPACE state output current

t_{SM} = Duration time of power dissipated during SPACE to MARK transition

C_L = Total load capacitance

t_M = Duration time of MARK state

t_S = Duration time of SPACE state

t_{BIT} = Time of bit interval

$$= \frac{C_L (V_{COMP} - V_{MO})}{I_{SC}} \quad (10)$$

These formulas are based upon an assumption of a linear discharge of a capacitive load.

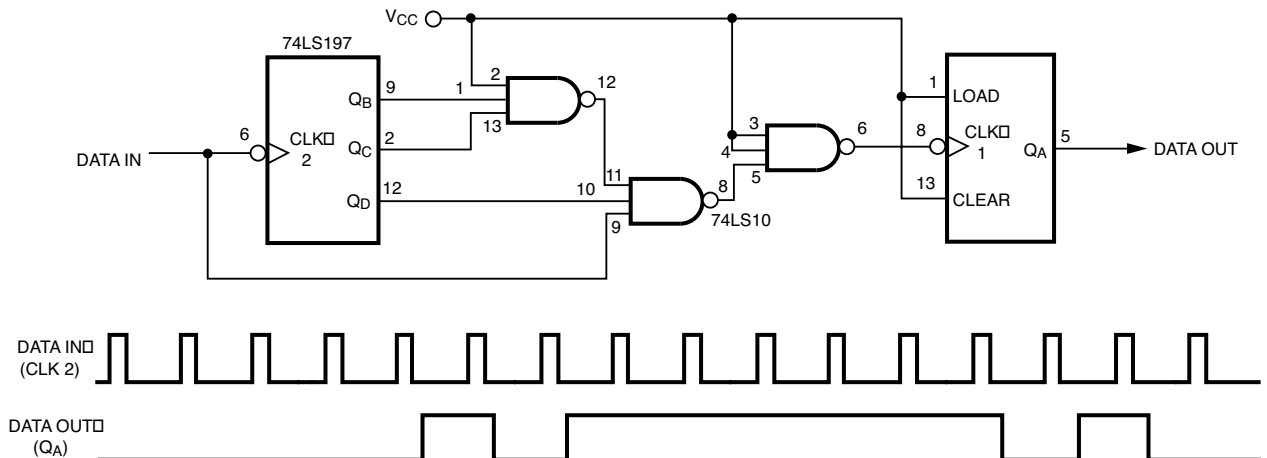

Figure 24. 16-bit TTL Data Exerciser Circuit and Corresponding Waveforms

Using equations (6) through (10), the worst case output power dissipated in the HCPL-4100 transmitter can be calculated for the following operating conditions.

$$L = 200 \text{ meters (656 ft.)}$$

$$C_L = 36,000 \text{ pF (180 pF/m)}$$

$$V_{\text{COMP}} = 23.5 \text{ V DC (} V_{\text{CC}} = 24 \text{ V DC)}$$

$$I_{\text{LOOP}} = 22 \text{ mA (20 mA + 10\%)}$$

$$I_{\text{SC}} = 85 \text{ mA}$$

$$T_A = 70^\circ\text{C}$$

CMOS LOGIC (15 V \pm 5%)

HCPL-4100 Power Dissipation Limits at 70°C

$$P_{\text{IN}} = 208 \text{ mW,}$$

$$P_{\text{TOTAL}} = 283.5 \text{ mW}$$

$$V_{\text{MO}} = 2.75 \text{ V at 22 mA}$$

$$I_{\text{SO}} = 2 \text{ mA}$$

$$t_{\text{BIT}} = 104.1 \text{ } \mu\text{s}$$

(9600 Baud, NRZ* alternating MARK and SPACE states. Reference Figure 25.)

*Non Return to Zero data format.

$$D = 25\% \text{ Distortion}$$

Calculation of maximum input power to the HCPL-4100 is based upon linear interpolation of maximum I_{CC} and I_{IH} .

$$\begin{aligned} P_{\text{IN}} &= V_{\text{CC}}I_{\text{CC}} + V_{\text{IH}}I_{\text{IH}} & (11) \\ &= (15.8 \text{ V})(12.6 \text{ mA}) + \\ &\quad (15.8 \text{ V})(0.206 \text{ mA}) \\ &= 202.3 \text{ mW.} < 208 \text{ mW max} \end{aligned}$$

Consequently, maximum derated output power is

$$\begin{aligned} P_{\text{O}} &= P_{\text{TOTAL}} - P_{\text{IN}} & (12) \\ &= 81.2 \text{ mW} \end{aligned}$$

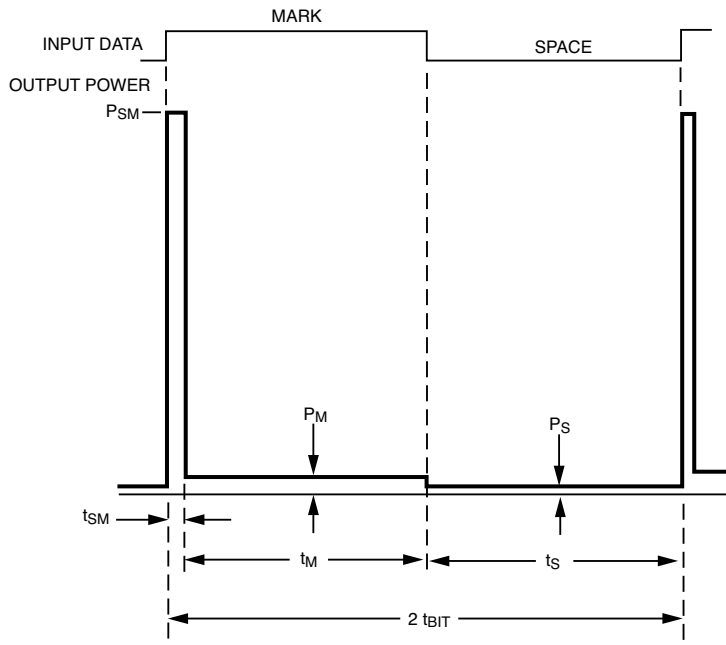

Figure 25. Output Power Dissipation over Two Bit Intervals in HCPL-4100 Transmitter.

Applying given values to equations (7), (8), (9), and (10) results in

$$P_{\text{SM}} = 1115.6 \text{ mW}$$

$$P_{\text{M}} = 60.5 \text{ mW}$$

$$P_{\text{S}} = 47 \text{ mW}$$

$$t_{\text{SM}} = 8.8 \text{ } \mu\text{s}$$

Equation (6) yields average output power per bit interval of

$$P_{\text{O}} = 98.4 \text{ mW} > 81.2 \text{ mW max}$$

To circumvent this excess output power dissipation condition, V_{CC} of the current source can be reduced from 24 V DC to 15 V DC. Recalculation with $V_{\text{CC}} = 15 \text{ V DC}$ yields

$$P_{\text{SM}} = 733.1 \text{ mW}$$

$$P_{\text{M}} = 60.5 \text{ mW}$$

$$P_{\text{S}} = 29 \text{ mW}$$

$$t_{\text{SM}} = 5.0 \text{ } \mu\text{s}$$

$$P_{\text{O}} = 60.9 \text{ mW} < 81.2 \text{ mW max}$$

The major compromises to reducing V_{CC} are that the maximum loop length is reduced by one half, and less capability exists for multidrop applications. However, the data rate can be doubled to 20 kBd at $V_{\text{CC}} = 15 \text{ V DC}$ over 200 meters.

Appendix C

Cable Data

The cable used throughout this application note contained five pairs of unshielded, twisted, 22 AWG wire (Dearborn No. 862205). The typical measured properties of this cable are listed below. Other manufacturers provide cable with similar characteristics, e.g., Belden No. 9745. Consult cable manufacturer catalogs for detailed information.

Z_O = 75 Ω , Characteristic Impedance—line to line
 R_{LINE} = 52.91 Ω /1000 m, DC Resistance—single conductor
 C = 174 pF/m, Capacitance—line to line
 t_{DELAY} = 5.9 nsec/m

Appendix D

List of Parameters

C_L = Total load capacitance
 f_D = Data rate at which D% output pulse distortion occurs
 I_{LOOP} = Operating loop current
 I_{SC} = MARK state short circuit output current
 I_{SO} = SPACE state output current
 L = Length of wire in one direction
 P_S = Power dissipated during SPACE state
 P_O = Average output power dissipated over a time interval
 P_{SM} = Power dissipated during SPACE to MARK transition
 P_M = Power dissipated during MARK state

R_{LINE} = DC resistance of wire per length
 R_S = Current setting resistor from non-isolated power supply
 t_{BIT} = Time of bit interval
 t_S = Duration time of SPACE state
 t_M = Duration time of MARK state
 t_{SM} = Duration time of SPACE to MARK transition
 V_{CC} = Power supply voltage
 V_{COMP} = Compliance voltage of current source
 V_{MO} = MARK state output voltage
 V_{RCVR_MARK} = Voltage across current loop receiver terminals when MARK state current flows
 V_{SAT} = Saturation voltage of current source
 V_{XMTR_MARK} = Voltage across current loop transmitter terminals when MARK state current flows

Appendix E

References

1. *Optoelectronics/Fiber Optics Application Manual*, Avago Technologies, Second Edition, McGraw-Hill, New York, 1981, pp. 3.1-3.77, 10.1-10.8.
2. True, Kenneth M., *The Interface Handbook—Line Drivers and Receivers*, Fairchild Semiconductor Components Group, Mountain View, CA, 1975, pp. 1-1 – 5-12.
3. McNamara, John E., *Technical Aspects of Data Communications*, Second Edition, Digital Equipment Corporation, Bedford, MA, 1982, pp. 13-21, 233-242.
4. Larsen, David G., Ronz, Peter R., Titus, Jonathan A., "INWAS: Interfacing with Asynchronous Serial Mode," *IEEE Transactions on Industrial Electronics and Control Instrumentation*, Vol. IECI-24, No. 1, February 1977, pp. 2-10.
5. *Avago 13266A Current Loop Converter User's Manual*, Avago Technologies, Palo Alto, CA, 1979.

For product information and a complete list of distributors, please go to our web site: www.avagotech.com