

SPECIFICATION

CONTACT RESISTANCE : 30m MAX
 INSULATION RESISTANCE: 50M MIN/100V DC
 BREAKDOWN VOLTAGE: 250V AC/1 MINUTE

回路構成
CIRCUIT

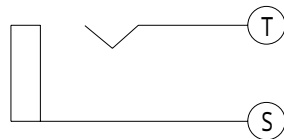

取付穴参考寸法
MOUNTING HOLE

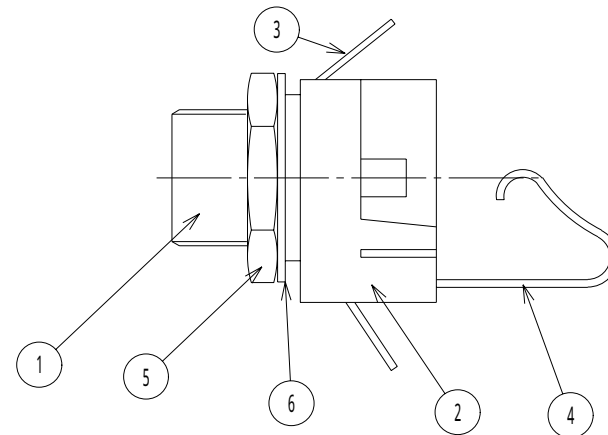
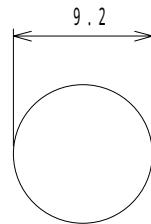

仕様	
耐電圧	AC 500V 1分間
絶縁抵抗	DC 500Vにて100M 以上
接触抵抗	50m 以下
挿抜力	5 ~ 40N

					TOLERANCE	SCALE	DATE	DESING	DRAW	INSPE	APRO
					±0.3	2/1		M.K	N.I		
6	平ワッシャー WASHER	ST	1	Ni			QTY	PART NAME	No.MJ-159M		
5	六角ナット NUT	ST	1	Ni	MODEL 型式						
4	チップパネ SPRING	PBS t=0.5	1	Ni	MATERIAL 材質		DRAW.NO 図番		MJ159M		
3	スリーブ端子 TERMINAL	BSR t=0.4	1	Ni	FINISH 処理		EST MARUSHIN ELECTRIC MFG.CO.,LTD.				
2	本体 BODY	ホリカーホネート PC	1								
1	スリーブメタル SLEEVE	BSBM	1	Ni							
LET	PART NAME	MATERIAL	QTY	FINISH	NOTE						