

1. General Description

With 16 built-in reverb and multi-effects, the V1000 Digital Multi-Effects DSP delivers outstanding audio performance in a rapid time-to-market solution at a very affordable price. Since the V1000 incorporates its own RAM and on-board effects, a complete reverb system can be designed with only the V1000, a low-cost ADC and DAC, and a simple 4-bit controller such as a rotary encoder etc.

2. Features

- **16 internal ROM programs consisting of effects such as multiple reverbs, echo, phaser, chorus, flanger, etc.**
- **Serially programmable SRAM (Writeable Control Store - WCS) for program development or dynamically changing programs**
- **Programs run at 128 instructions per word clock. (6 MIPS @ 48 khz sampling frequency)**
- **32k location Static Ram provides over 0.68 sec of delay at 48 kHz sampling frequency**
- **Package outline: SOIC-16/300**
- **ROHS compliant (PB-free)**

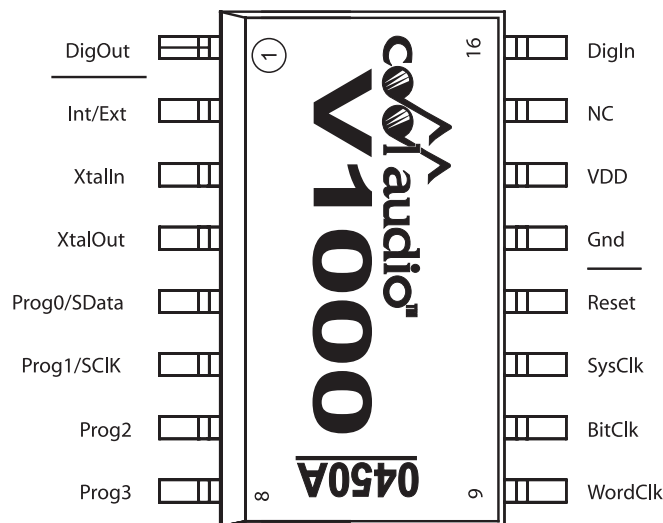

16 pin SOIC
300mils wide

Information furnished by COOLAUDIO is believed to be accurate and reliable. However, no responsibility is assumed by COOLAUDIO for its use, nor for any infringements of patents or other rights of third parties which may result from its use. No license is granted by implication or otherwise under any patent or patent rights of COOLAUDIO.

Rev. 1.0

3. Electrical Characteristics and Operating Conditions

| Parameter | Description | Condition | Min | Typ | Max | Units |
|-----------------|----------------|-----------|-----|-----|-----|-------|
| VDD | Supply Voltage | | 3.0 | 3.3 | 3.6 | V |
| I _{dd} | Supply Current | | | 24 | | mA |
| Gnd | Ground | | | 0.0 | | V |
| F _s | Sample Rate | | 20 | 48 | | kHz |

4. Outputs (DigOut, SysClk, BitClk, WordClk)

| Parameter | Description | Condition | Min | Typ | Max | Units |
|-----------------|--------------------------|-----------|-----|-----|-----|-------|
| V _{OH} | Logic "1" output voltage | Unloaded | 2.9 | – | – | V |
| V _{OL} | Logic "0" output voltage | Unloaded | – | 0 | 0.6 | V |

5. Inputs (DigIn, Int/Ext_, Prog0/Sdata, Prog1/SClk, Prog2, Prog3, Reset_)

| Parameter | Description | Condition | Min | Typ | Max | Units |
|-----------------|-------------------------|-----------|-----|-----|---------------------|-------|
| V _{IH} | Logic "1" input voltage | | 2.0 | – | 5.0 | V |
| V _{IL} | Logic "0" input voltage | | 0.0 | – | 0.3*V _{dd} | V |

6. Pin Descriptions V1000

| Pin# | Name | PinType | Description |
|------|-------------|---------|--|
| 1 | DigOut | Output | Digital serial output for stereo DAC |
| 2 | Int/Ext_ | Input | Internal/external program selection |
| 3 | XtalIn | Input | 12.288 MHz crystal input |
| 4 | XtalOut | Output | 12.288 MHz crystal output |
| 5 | Prog0/SData | Input | Internal program select0/serial interface data line |
| 6 | Prog1/SClk | Input | Internal program select1/serial interface clock line |
| 7 | Prog2 | Input | Internal program select2 |
| 8 | Prog3 | Input | Internal program select3 |
| 9 | WordClk | Output | Word clock output |
| 10 | BitClk | Output | Bit clock output |
| 11 | SysClk | Output | System clock output |
| 12 | Reset_ | Input | Active low reset |
| 13 | Gnd | Ground | Ground connection |
| 14 | Vdd | Power | Vdd power pin |
| 15 | NC | | |
| 16 | DigIn | Input | Digital serial input for stereo ADC |

Note:

Int/Ext_, prog0, prog1, prog2 and prog3 are pulled up to Vdd via nominal internal 30k resistor.

7. Block Diagram

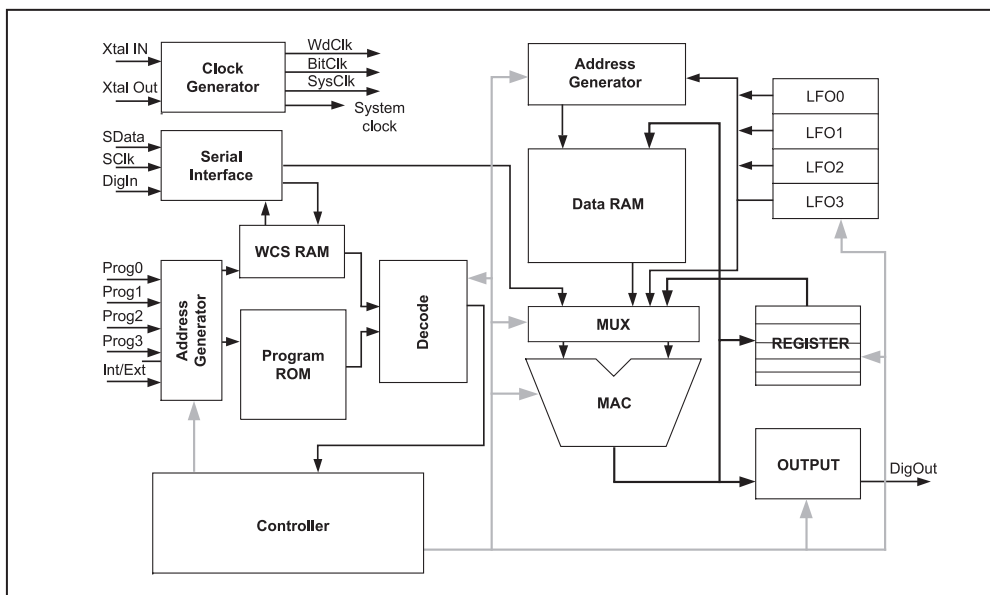

8. Internal Programs

The SCR comes with 16 internal ROM programs ready to go. By setting the chip to internal mode, the four program pins may be used to select between the different algorithms.

| Prog[3:0] | Name | Description |
|-----------|----------|-------------------------------|
| 0000 | Medium | Reverb, Small hall (1.5 sec.) |
| 0001 | Chambr7b | Reverb, Big hall (2.8 sec.) |
| 0010 | Room3b | Reverb, Room (1.8 sec.) |
| 0011 | Chamber2 | Reverb, Church (7 sec.) |
| 0100 | Revers3b | Reverb Reverse (1.2 sec.) |
| 0101 | Gated4b | Reverb Gated (0.8 sec.) |
| 0110 | Room2a | Reverb Chapel (3 sec.) |
| 0111 | Spring3b | Reverb Spring (2 sec.) |
| 1000 | Phaser1 | Phaser |
| 1001 | Flanger2 | Flanger |
| 1010 | Delay7 | Echo |
| 1011 | Chorus4 | Chorus |
| 1100 | Earlref4 | Early Reflection |
| 1101 | Amb4 | Big Ambience |
| 1110 | Delay3 | Stereo Delay |
| 1111 | Delay1 | Slap-back Delay |

9. Programming the RAM

Alongside the 16 internal programs is an externally programmable SRAM that is easily accessible through the serial clock and data pins, by setting the chip to external mode, the SClk and SData pins become available for serial communication. Except for its external programmability, there is no functional difference between the SRAM and the internal ROMs.

10. Memory Map

| Addr | | Name | |
|-------|------------------|-------|------------------|
| 0.127 | WCS RAM | Addr | Name |
| | | 0:3 | LFO Coefficients |
| | | 4:127 | MAC Instructions |
| 128 | Control/Status 0 | | |

11. LFO Coefficient Word

| Bit# | Description | | |
|-------|--|--------|-------|
| 31 | P: Pitch shift mode select (S must be set). | | |
| 30 | S: sine/triangle select. 1:Triangle; 0: Sine. | | |
| 29:28 | X[1:0]: Cross fade Coefficient select. Value indicates the fraction of a half sawtooth period used in cross fading | X[1:0] | Xfade |
| | | 11 | 1/16 |
| | | 10 | 1/8 |
| | | 01 | 1/2 |
| 00 | 1 | | |
| 27:25 | F[12:0]: Frequency coefficient, unsigned. | | |
| 14:0 | A[14:0]: Amplitude coefficient, unsigned. | | |

Note:

If set, the output wave form is a sawtooth with double the triangle wave's frequency.

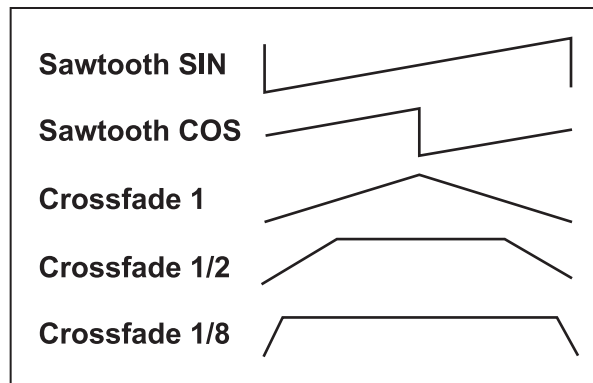

Notes:

1. Crossfade only used in saw tooth wave.
2. The sinusoid generated by the LFOs is or the formula $A\sin(nF / M)$ or $A\cos(nF / M)$, where n is the time index, $F/M - 2 \pi f/Fs$, M is the maximum internal value, fit the selected frequency, and Fs is the sampling frequency.

Thus the frequency limits are:

$$f = (F/M) Fs / (2\pi)$$

For triangle waves, its frequency limits are

$$f = Fs / (4 \text{ Max / Increment})$$

$$= Fs / (4 \cdot 0x7fffff / 222 * F/M)$$

12. MAC Instruction Word

| Bit# | Description | | | |
|-------|--|---|---------------------------|------------------|
| 31 | S: Sign bit for multiplier coefficient. | | | |
| 30:23 | C[7:1]: Multiplier coefficient, 2's complement. | | | |
| | C[7:0] Chorus instruction. Only the 7 MSBs are used as multiplier coefficients. The LSB is used in chorus mode. If I[15] is set, C[7:0] is : | | | |
| | C Description | | | |
| | 7 | Chorus/Xfade select | | |
| | | 1: Pass LFO address to address generator & select chorus coefficient | | |
| | | 0: Mask LFO address to address generator & select cross fade coefficient. | | |
| | 6 | 1's complement the LFO address sign bit. | | |
| | 5 | 1's complement the LFO address sign bit. | | |
| | 4 | 1's complement the LFO address. | | |
| | 3 | LFO latch. 1: Latch in new LFO data; 0: Hold last LFO data | | |
| 2:1 | LFO select. | | | |
| 0 | LFO sine / cosine select. | | | |
| | 1: Cos; 0: Sin. | | | |
| 22 | W: Write select. | | | |
| 21:16 | I[5:0]: Instruction field | | | |
| | I Description | | | |
| | 5 | Chorus select (When set, MAC coefficient is LFO block output, LFO address offset added to SRAM address) | | |
| | 4 | Clock register C. | | |
| | 3 | Clock register B. | | |
| 2 | Reserved – set to zero. | | | |
| 21:16 | 1 : 0 | MAC product instruction | I[1:0] Instruction | |
| | | | 11 | Acc = Prod + Acc |
| | | | 10 | Acc = Prod + C |
| | | | 01 | Acc = Prod + B |
| | | | 00 | Acc = Prod + O |
| 15:0 | A[15:0]: Multiplicand address. (Currently only lower 15 bits used; reserve MSB for future expansion.) Address 0x0000 = LeftIn / Out; Address 0x0001 = RightIn / Out. | | | |

Notes:

1. This complement is only for the MSB, and sign-extension bits are not affected.
2. The LeftOut, RightOut, and C registers are in parallel with the accumulator, and will contain the same value as the accumulator if clocked at the end of the tick. Thus, a write to LeftOut or RightOut will store the current tick's results.
3. A write to SRAM stores the last tick's results into address A. During writes, the multiplicand is set to be the Acc, since A[15:0] is used for the excursion address. Writes to LeftOut or RightOut can use the Acc = Product + Acc instruction with the multiplier coefficient set to 0 to pass all bits unaltered.
4. Register B, if clocked at the end of the tick, will store the value of the current tick's multiplicand. When a read is executed, B latches LeftIn, RightIn, or SRAM. When a write is executed, B latches the accumulator from the last tick.
5. The accumulator contains the result from the last instruction tick, and is updated at the end of the current instruction tick.
6. The internal SRAM address offset automatically decrements by 1 every word clock period.
7. Because addresses 0x0000 and 0x0001 are being used to access the left and right channels, those SRAM memory locations may not be directly written to or read from.

13. Control / Status Word 0

| Bit # | Description |
|-------|---|
| 31:8 | Reserved. Set to zero. |
| 7 | M: DigOut mute in external mode. Resets to 1. |
| 6 | Z: SRAM zero. Initiates zeroing cycles until de-asserted. Resets to 0. |
| 5 | Reserved. Set to zero. |
| 4 | L: LFO reset pulse. Resets LFO internal status registers and clears overflow flag. Self clearing. Resets to 0. |
| 3 | I: Instruction RAM direct mode. Resets to 1. 1: Instructions are written / read as soon as received; 0: Instructions are written / read when the address counter rolls around to matching address. |
| 2:0 | Reserved. Set to zero. |

14. Instruction Set

LFO Declarations

The LFOs must be set up with operating parameters if you want to use them. These include amplitude and frequency coefficients, and waveform selection. The setup information for the four LFOs occupy the first four ticks in the program RAM, but the LFO setup declarations may be anywhere in the input file.

LFO_n=[wav] AMP=[amp] FREQ=[freq] XFAD=[xfad]

n: LFO selection. LFOs 0 through 3 are available.

[wav]: Waveform selection. SIN: sinusoid. TRI: triangle. SAW: saw tooth.

[amp]: Waveform amplitude coefficient. ±[amp]/8 samples. 15-bit value.

[freq]: Waveform frequency coefficient. 13-bit value.

[xfad]: Cross fade coefficient selection. Choices are: 1, 1/2, 1/8, 1/16. Used for SAW waveform only.

MAC mnemonic

READ INSTRUCTIONS

RZP Read, Acc = Zero + Product
RAP Read, Acc = Acc + Product
RBP Read, Acc = B Register + Product
RCP Read, Acc = C Register + Product
RZPB Read, Acc = Zero + Product, Load B register
RAPB Read, Acc = Acc + Product, Load B register
RBPB Read, Acc = B Register + Product, Load B register
RCPB Read, Acc = C Register + Product, Load B register
RZPC Read, Acc = Zero + Product, Load C register
RAPC Read, Acc = Acc + Product, Load C register
RBPC Read, Acc = B Register + Product, Load C register
RCPC Read, Acc = C Register + Product, Load C register
RZPBC Read, Acc = Zero + Product, Load B and C registers
RAPBC Read, Acc = Acc + Product, Load B and C registers
RBPBC Read, Acc = B Register + Product, Load B and C registers
RCPBC Read, Acc = C Register + Product, Load B and C registers

WRITE INSTRUCTIONS

WZP Write, Acc = Zero + Product
WAP Write, Acc = Acc + Product
WBP Write, Acc = B Register + Product
WCP Write, Acc = C Register + Product
WZPB Write, Acc = Zero + Product, Load B register
WAPB Write, Acc = Acc + Product, Load B register
WBPB Write, Acc = B Register + Product, Load B register
WCPB Write, Acc = C Register + Product, Load B register
WZPC Write, Acc = Zero + Product, Load C register
WAPC Write, Acc = Acc + Product, Load C register
WBPC Write, Acc = B Register + Product, Load C register
WCPC Write, Acc = C Register + Product, Load C register
WZPBC Write, Acc = Zero + Product, Load B and C registers
WAPBC Write, Acc = Acc + Product, Load B and C registers
WBPBC Write, Acc = B Register + Product, Load B and C registers
WCPBC Write, Acc = C Register + Product, Load B and C registers

CHORUS mnemonic

CHRn [MAC mnemonic] [label] [chorus controls] [optional statements]

The first three statements are required in the order given. The chorus controls and optional statements may then follow in any order, although for readability the above convention should be followed.

DATA Memory Access

The MEM instruction creates a block of memory from the free memory stack. The ABS instruction specifies one particular address, useful for buffers that only require one memory location.

One sample of delay requires 2 memory locations, 10 samples of delay requires 11 memory locations, etc. Memory is allocated from the free memory stack as it is requested

Examples:

MEM delay 1024; 1024 location delay block.

MEM buff3 0x0400; 1024 location buffer.

ABS store 2; Storage location at address 2.

ABS temp2 0x7FFF; Temporary storage at address 32767.

15. Serial Interface Format

The basic format for the micro serial interface is:

Attn Sel R/W A7 A6 A5 A4 A3 A2 A1 A0 DN DN-1 DN-2 ... D2 D1 D0 Attn Desel

Attn : A 0-1-0 is used to signal attention / start.

Sel / Desel : 0: Select; 1: Deselect.

A7 – A0 : Address.

R /W : 0: Read; 1: Write.

DN – D0 : Data

Attn Desel : Write mode only.

Notes:

1. As long as data is being send during a write, the address will be automatically incremented. Therefore only a start address need be sent.
2. The phase of the clock is unimportant.

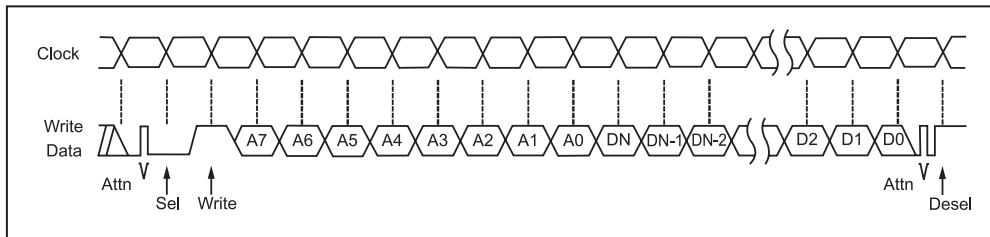

Write Timing ($T_{cyc} = 1/F_{masterClk}$)

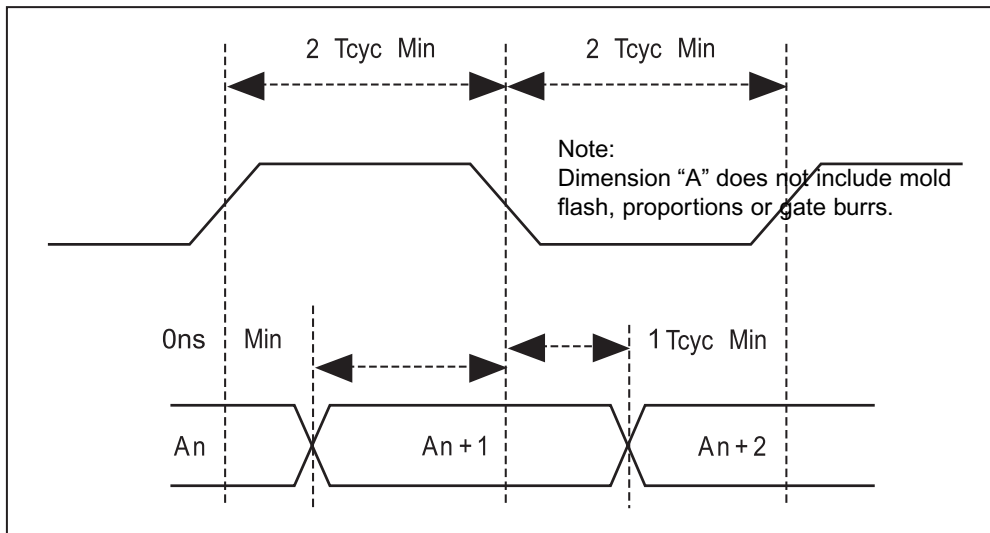

DigIn / DigOut Interface Format

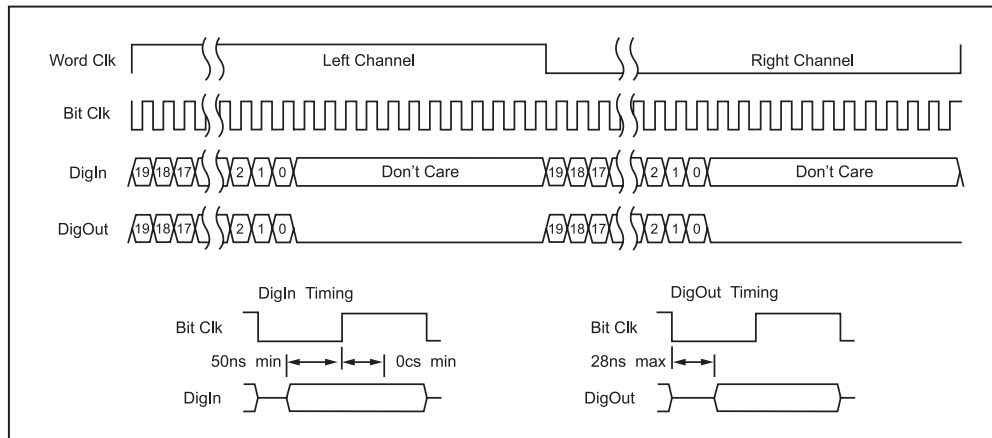

16. Mechanical Specification

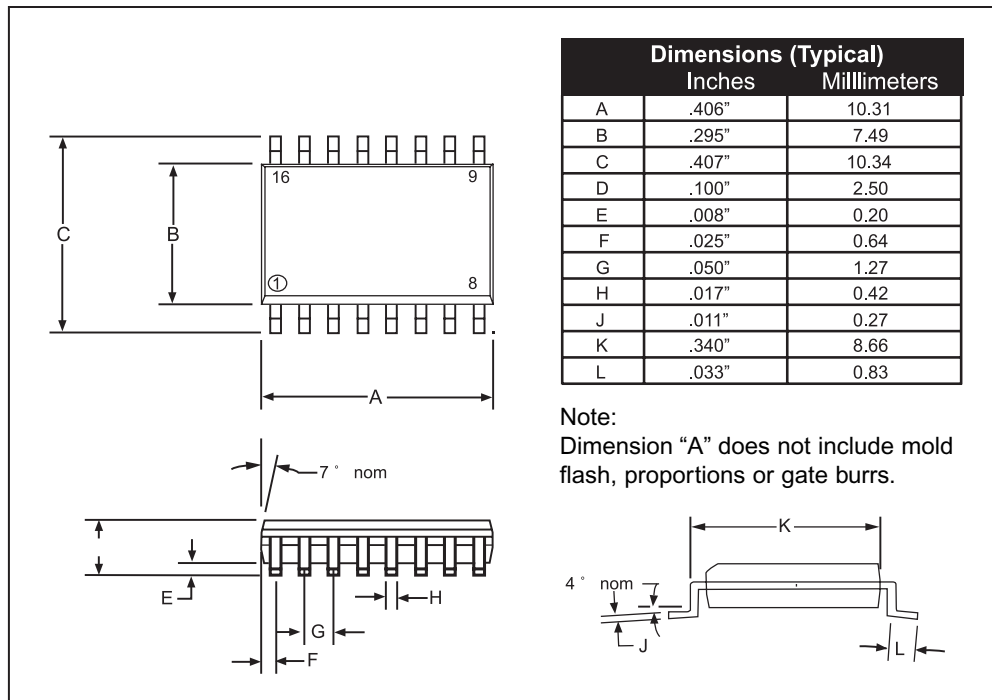

17. Schematic Diagrams

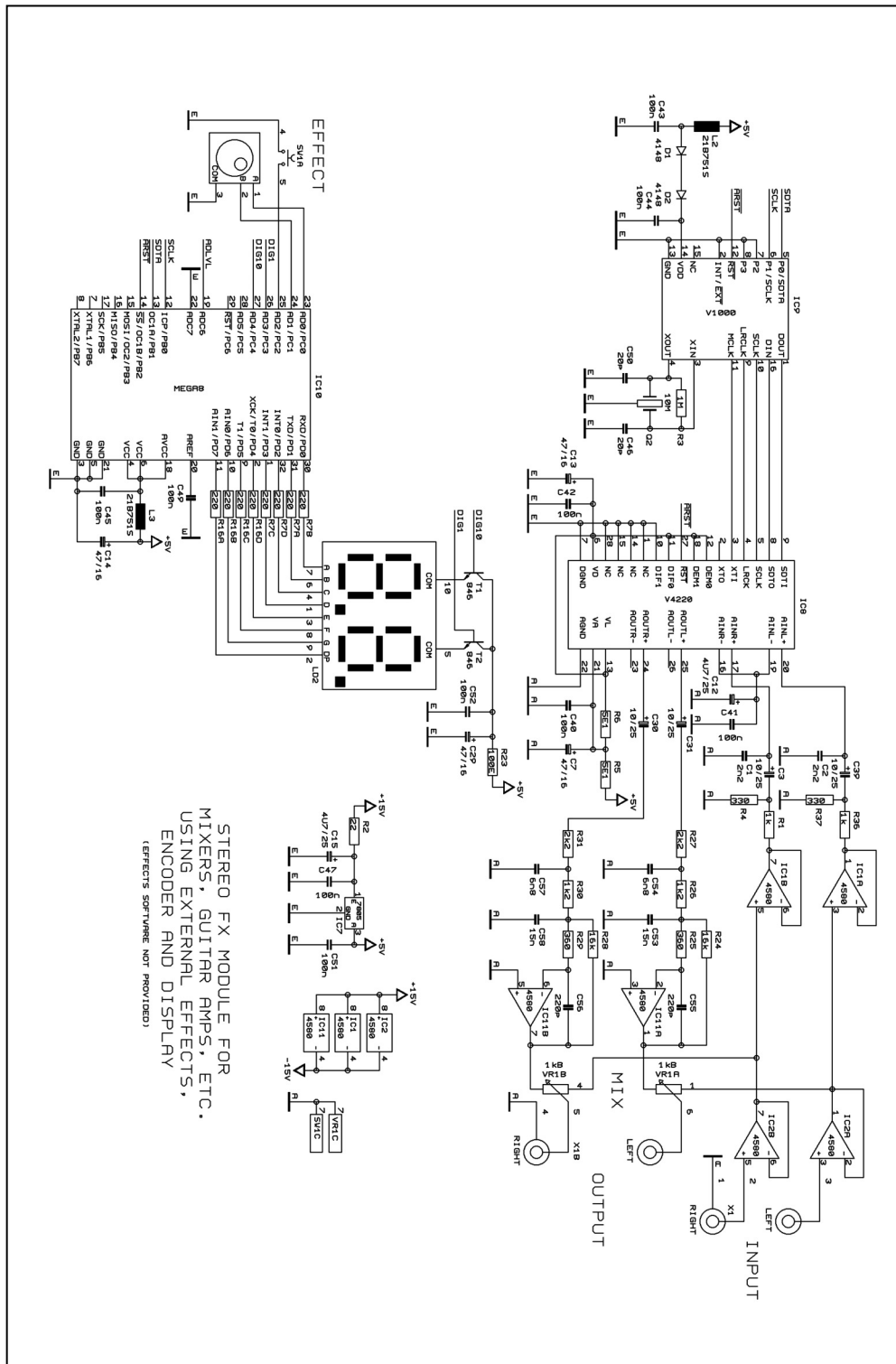

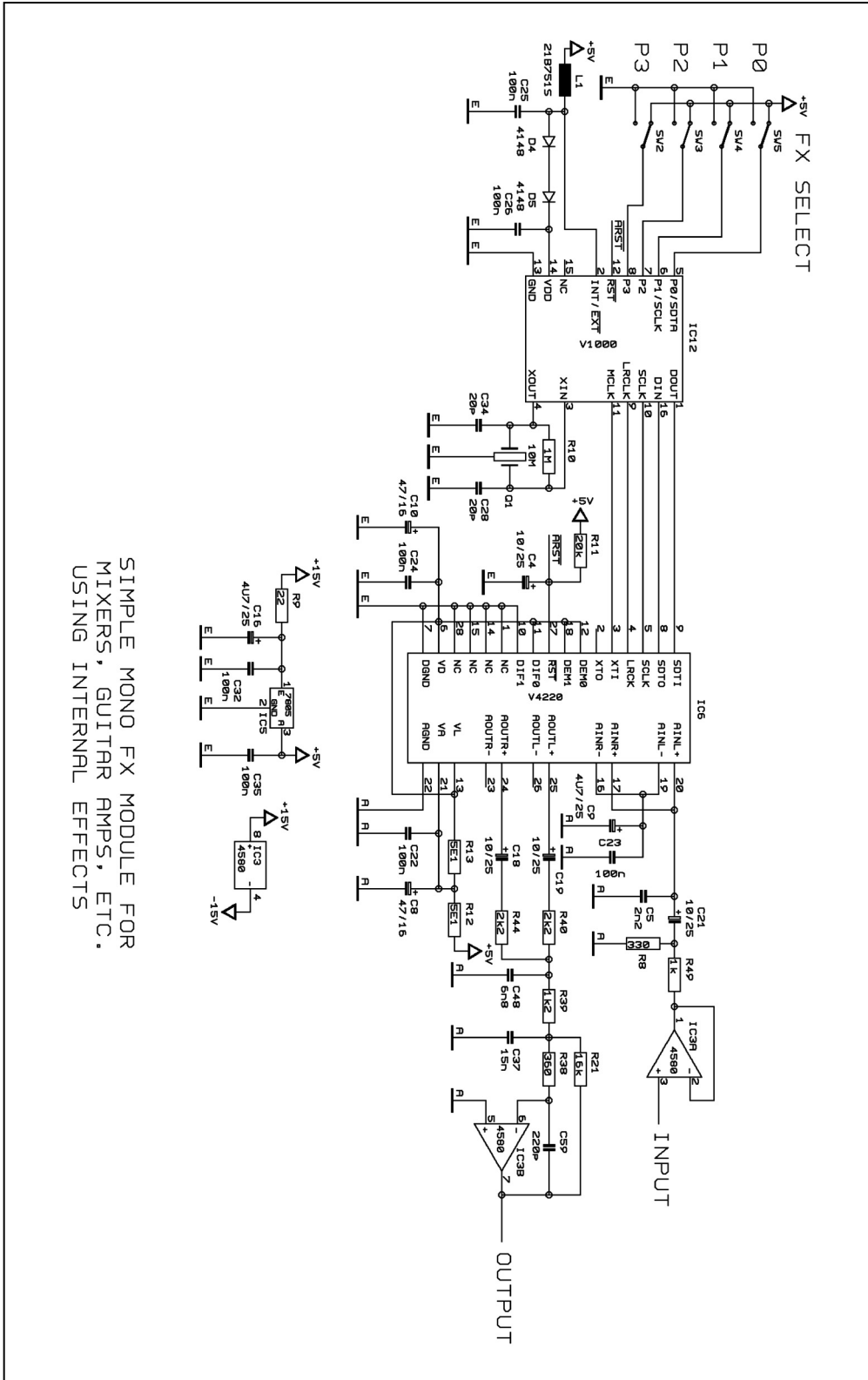

SIMPLE MONO FX MODULE FOR MIXERS, GUITAR AMPS, ETC. USING INTERNAL EFFECTS