

1. Description

The V3102 is a universal CMOS LSI to generate a two-phase clock signal of low output impedance, perfectly suitable to drive BBDs up to 4096 stages, such as V3207, V3208, V3205, etc.

2. Features

- Direct driving capability of up to 4096-stage BBD's
- Self-oscillation or separate excitation possible
- Two phase clock output (duty: 1/2)
- Incorporates a diode to protect the IGBT gate at power on
- Package outline: DIL-8 (V3102D)
- ROHS compliant (PB-free)

3. Pin Configuration

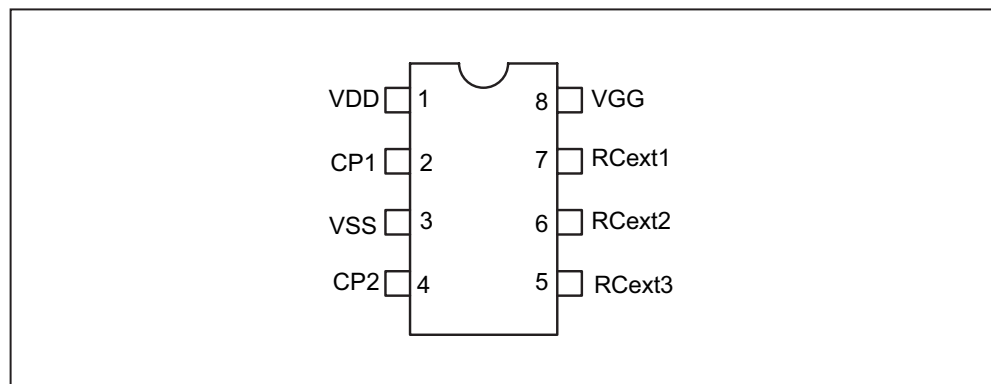

Information furnished by COOLAUDIO is believed to be accurate and reliable. However, no responsibility is assumed by COOLAUDIO for its use, nor for any infringements of patents or other rights of third parties which may result from its use. No license is granted by implication or otherwise under any patent or patent rights of COOLAUDIO.

Rev. 1.0

4. Absolute Maximum Ratings (Tamb=25°C)

Parameter	Symbol	Min	Max	Unit
Collector Supply Voltage	V _{CC}	-0.3	12	V
Input Voltage	V _I , V _O	-0.3	V _{CC} +0.3	V
Power Dissipation	P _D		200	mW
Operating Temperature	T _{amb}	-10	70	°C
Storage Temperature	T _{stg}	-30	125	°C

5. Electrical Characteristics (T_a=25°C, V_{CC}=20V, Unless otherwise specified)

Parameter	Symbol	Test Condition	Min	Typ.	Max	Unit
Drain Supply Current	I _{CC}	R _L =∞, F ₀ =40KHZ		0.5		mA
Total Power Dissipation	P _{tot}			2.5		mW
Input Current "H" Level	V _{IH}	V _{CC} =5V, 10V	V _{CC} -1		V _{CC}	V
Input Current "L" Level	V _{IL}	V _{CC} =5V, 10V	0		1	V
Input High Leakage Current	I _{IH} (L)	V _I =10V			30	μA
Input Low Leakage Current	I _{IL} (L)	V _I =10V			30	μA
Output Current "H" Level	I _{OH} (1)	V _{CC} =5V, V _O =4V	0.5			mA
Output Current "L" Level	I _{OL} (1)	V _{CC} =5V, V _O =1V	0.4			mA
Output Leakage Current "H" Level	I _{OH} (L1)	V _{CC} =10V, V _O =V _{CC}			30	μA
Output Leakage Current "L" Level	I _{OL} (L1)	V _{CC} =10V, V _O =V _{SS}			30	μA
Output Current "H" Level	I _{OH} (L2)	V _{CC} =5V, V _O =4V	0.7			mA
Output Current "L" Level	I _{OL} (L2)	V _{CC} =5V, V _O =1V	1			mA
Output Leakage Current "H" Level	I _{OH} (L2)	V _{CC} =10V, V _O =V _{CC}			30	μA
Output Leakage Current "L" Level	I _{OL} (L2)	V _{CC} =10V, V _O =V _{SS}			30	μA
Output Current "H" Level	I _{OH} (3)	V _{CC} =5V, V _O =4V	5			mA
Output Current "L" Level	I _{OL} (3)	V _{CC} =5V, V _O =1V	5			mA
Output Leakage Current "H" Level	I _{OH} (L3)	V _{CC} =10V, V _O =V _{CC}			30	μA
Output Leakage Current "L" Level	I _{OL} (L3)	V _{CC} =10V, V _O =V _{SS}			30	μA

6. Application Circuit

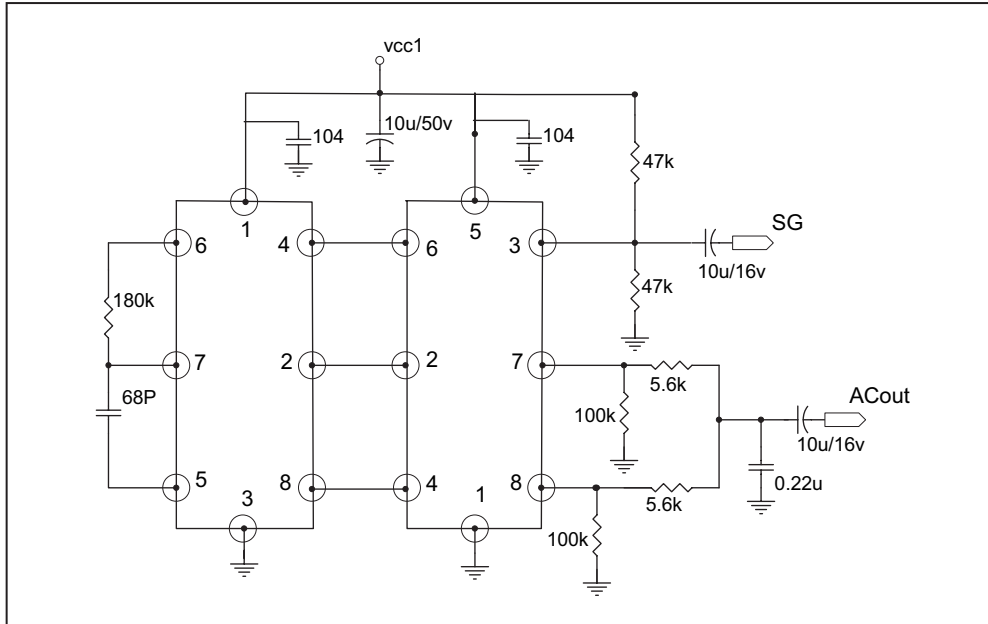

7. Mechanical Drawing

