

FOR RoHS

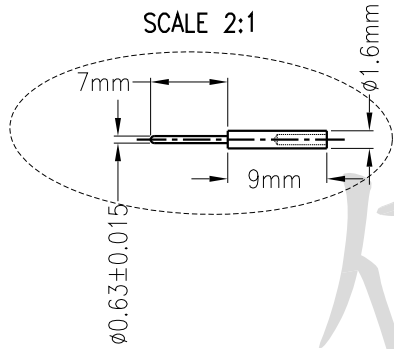

CABLE: UL1007 24AWG
 CN1/CN2: MACHINE PIN 0.63mm (BRASS)
 HEAT SHRINK TUBE (BLACK)
 PACKING: PE BAG, CARD (10pcs/bag)

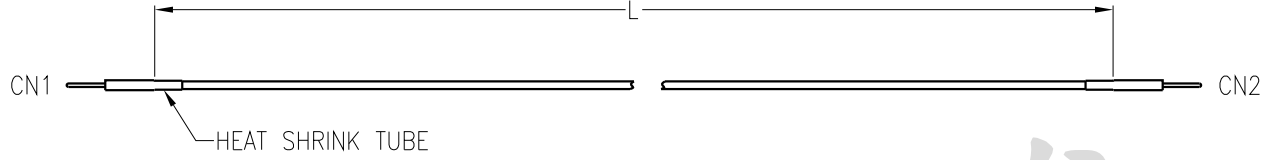
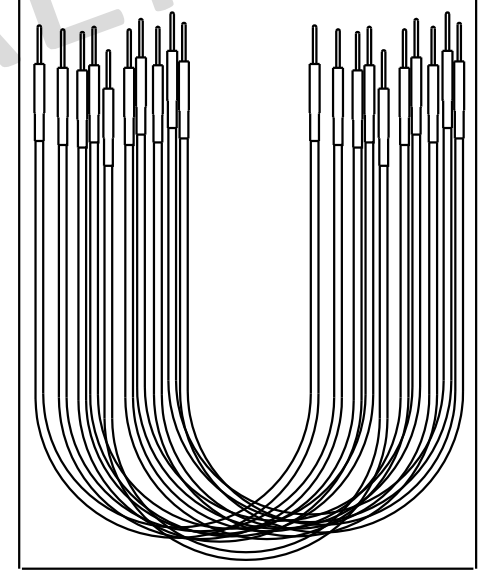
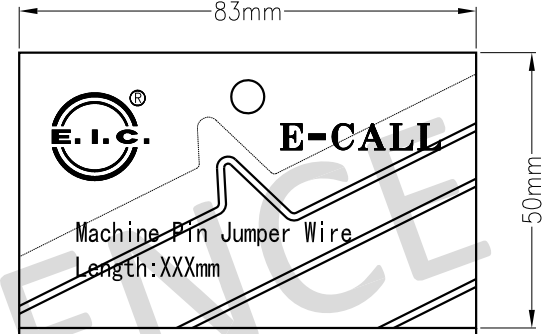

10 PCS

0116-719-XX-0XX

SERIES NO. L (LENGTH)

MALE TO MALE TYPE COLOR CODE

005: 50mm REF.
 007: 70mm REF.
 010: 100mm REF.
 015: 150mm REF.
 020: 200mm REF.

01: RED
 02: BLUE
 03: YELLOW
 04: GREEN
 05: BLACK
 06: BROWN
 07: ORANGE
 08: GRAY
 09: WHITE
 11: PURPLE

All materials can be replaced with equivalent by any suppliers

E.I.C. E-CALL ENTERPRISE CO.,LTD.

TITLE: JUMPER WIRE

PART NO: 0116-719-XX-0XX

DWG NO: 022300-C1502

TOLERANCE			
X.	±	REVISE	Oct.12..20'
.X	±	NEW RELEASE	Feb.23.09'
.XX	±	DESCRIPTION	DATE
.XXX	±		

APPD:	MAT'L:
CHKD: Chun.Ter.Chlu	BODY:
DRWN: Wen.Kai	CLIENT: ALL

UNITS	SCALE	SHEET
	mm	1:1