

# UM-1

## High Stability Quartz Crystal Unit

### Feature

- Resistance weld completely sealed.
- Wide frequency range.
- Excellent aging characteristics.
- Tight stability over Extended Temperature.
- Excellent shock resistance.

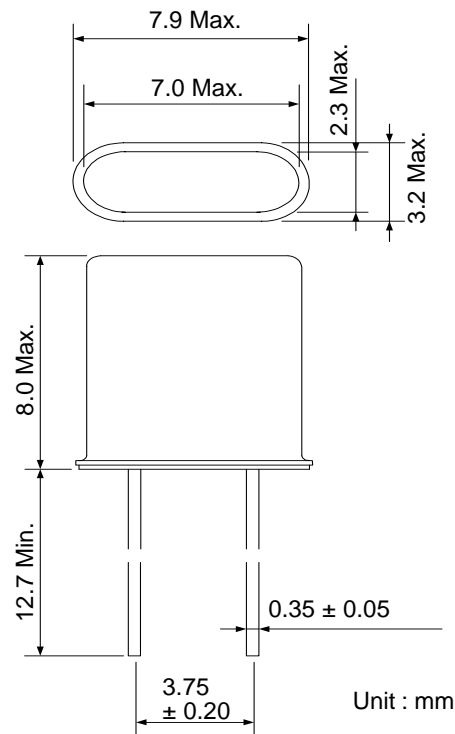

Specification	
Mode of Vibration	Fundamental,3rd ,5th,7th Overtone
FQ. Range	6.4 ~ 185 MHz
Drive Level	10 micro watt ~ 1m watt
ESR	60 ohms max.
Lode Capacitance	8pF ~ 32pF or Series Resonance
Frequency Tolerance(25DEG C)	± 3 ppm ~
Frequency Tolerance Over The Oper. Temp.Range	± 2.5 ppm ~
Operating Temp.Range	-30 ~ +85 (DEG C)
Shunt Capacitance	7.0pF max.
Machanical Performance	
Gross Leak	The crystal units shall be immersed in 90(DEG C) Hot water for a specified time There shall be on leakage as determined by repetitive bubbles emerging from the crystal units.
Slow Leak	The crystal units shall be immersed in Leak detector for a specified period time there shall be on leakage as determined by repetitive $1 \times 10^{-3}$ pa cc/s from the crystal units.
Shock	The crystal units shall be capable of with standing "free fall"from a hight of 750mm onto hard wooden plate for 3 times; Fs=±3.0ppm max. ESR=±2.0 ohms or 15% whichever is Larger
Vibration	The crystal units shall be capable of with standing each one hour in 3 directions 10~55Hz amplitude 1.5mm; Fs=±3.0ppm max. ESR:±2.0 ohms or 15% whichever is Larger
Humidity	96Hours at 40±2(DEG C) and 90~95%,Respectively Fs=±3.0ppm max. ESR=±2.0 ohms or 15% whichevere is Larger Insulation Resistance :500M ohms min.DC100V

Crystal Units