

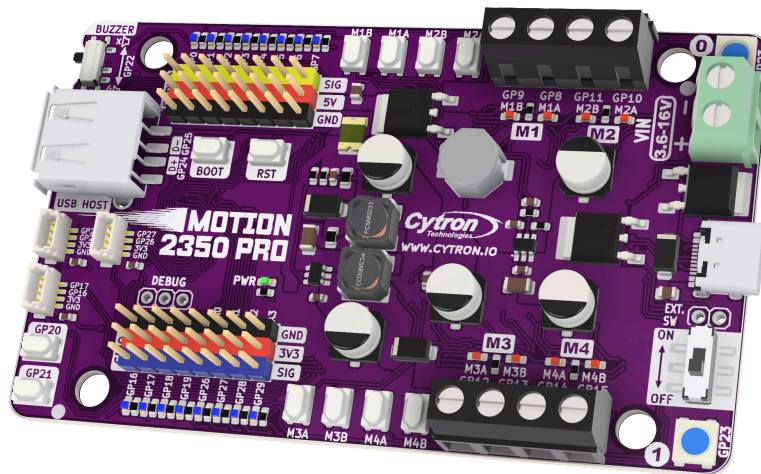

MOTION 2350 Pro

An Advanced Robotics Controller for Beginners



Datasheet

Rev 1.0
July 2024

Information in this publication regarding device applications and the like is intended through suggestion only and may be superseded by updates. It is your responsibility to ensure that your application meets with your specifications. No representation or warranty is given and no liability is assumed by Cytron Technologies Incorporated with respect to the accuracy or use of such information or infringement of patents or other intellectual property rights arising from such use or otherwise. Use of Cytron Technologies's products as critical components in life support systems is not authorized except with express written approval by Cytron Technologies. No licenses are conveyed, implicitly or otherwise, under any intellectual property rights.

1. BOARD LAYOUT & FUNCTION

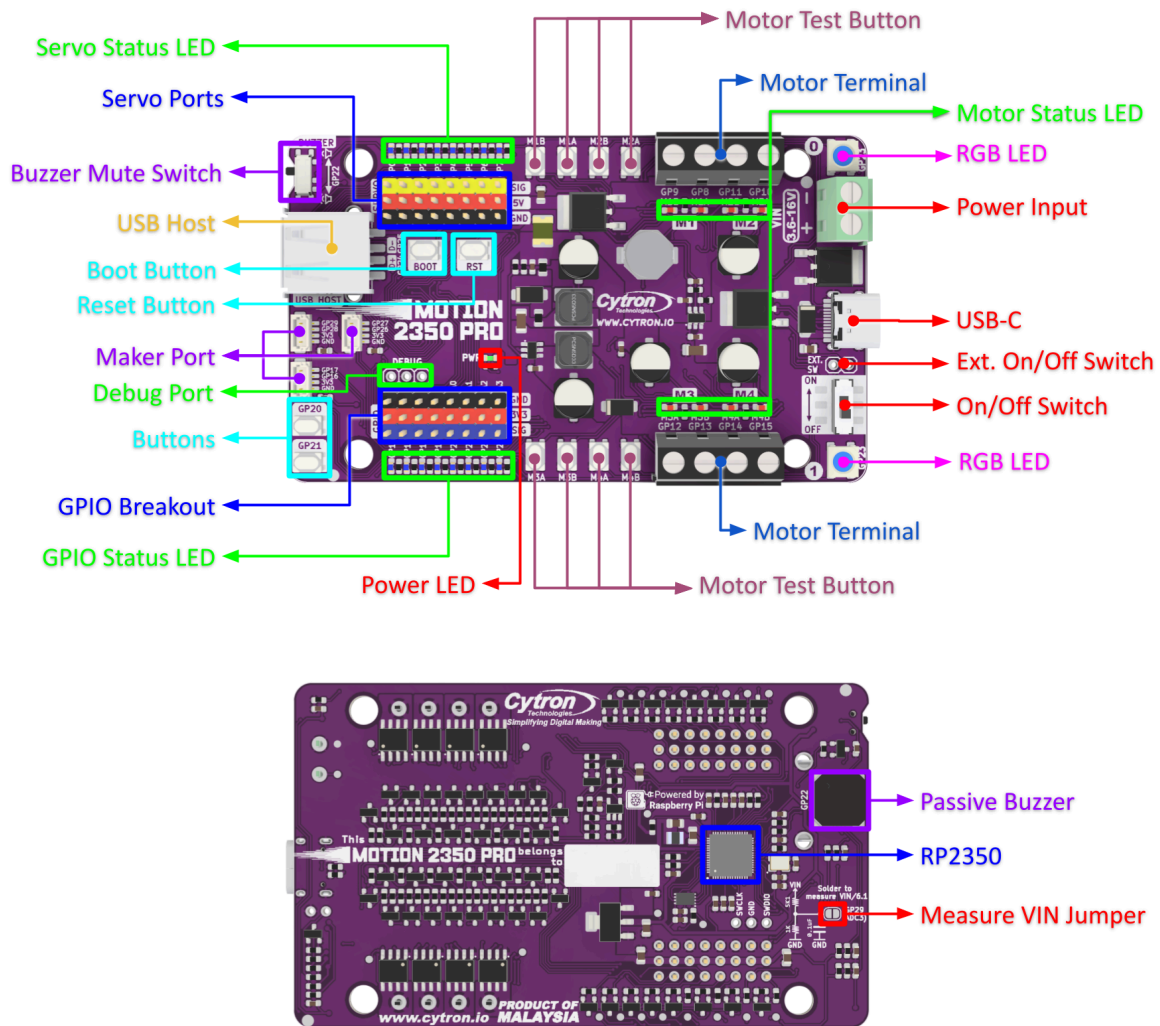

Figure 1: MOTION 2350 Pro Board Functions

Function	Description	
Power Input	Terminal for external 3.6V - 16V DC power input. Can be powered up with external LiPo or 4x AA batteries.	
On/Off Switch	Turn On/Off the power.	
Ext. On/Off Switch	Header for external On/Off switch. The onboard switch must be in Off position to use the external switch.	
5V Supply	Power output for external servos. Controlled by an automatic voltage selector, the output of 5V supply depends on the input from the VIN.	
	VIN	5V Supply output
	VIN > 5.8V	It will step down the VIN voltage to 5V.
	VIN < 5.5V	It will follow the VIN voltage.

USB-C	Used for upload programs from PC. Used to power up the board.																																																						
GPIO/Servo Status LEDs	LED indicator for digital IO. Turn on when the IO state is high.																																																						
GPIOs Breakout	Arranged in color-coded GVS format. With 3.3V power output for each GPIO.																																																						
	<table border="1" style="width: 100%; border-collapse: collapse; text-align: center;"> <thead> <tr style="background-color: #0056b3; color: white;"> <th>GPIO</th> <th>PWM</th> <th>SPI</th> <th>I2C</th> <th>UART</th> <th>Analog</th> </tr> </thead> <tbody> <tr> <td>16</td> <td>PWM0-A</td> <td>SPI0 SDI</td> <td>I2C0 SDA</td> <td>UART0 TX</td> <td>-</td> </tr> <tr> <td>17</td> <td>PWM0-B</td> <td>SPI0 CSn</td> <td>I2C0 SCL</td> <td>UART0 RX</td> <td>-</td> </tr> <tr> <td>18</td> <td>PWM1-A</td> <td>SPI0 SCK</td> <td>I2C1 SDA</td> <td>UART0 CTS</td> <td>-</td> </tr> <tr> <td>19</td> <td>PWM1-B</td> <td>SPI0 SDO</td> <td>I2C1 SCL</td> <td>UART0 RTS</td> <td>-</td> </tr> <tr> <td>26</td> <td>PWM5-A</td> <td>SPI1 SCK</td> <td>I2C1 SDA</td> <td>UART1 CTS</td> <td>ADC0</td> </tr> <tr> <td>27</td> <td>PWM5-B</td> <td>SPI1 SDO</td> <td>I2C1 SCL</td> <td>UART1 RTS</td> <td>ADC1</td> </tr> <tr> <td>28</td> <td>PWM6-A</td> <td>SPI1 SDI</td> <td>I2C0 SDA</td> <td>UART0 TX</td> <td>ADC2</td> </tr> <tr> <td>29</td> <td>PWM6-B</td> <td>SPI1 CSn</td> <td>I2C0 SCL</td> <td>UART0 RX</td> <td>ADC3</td> </tr> </tbody> </table>	GPIO	PWM	SPI	I2C	UART	Analog	16	PWM0-A	SPI0 SDI	I2C0 SDA	UART0 TX	-	17	PWM0-B	SPI0 CSn	I2C0 SCL	UART0 RX	-	18	PWM1-A	SPI0 SCK	I2C1 SDA	UART0 CTS	-	19	PWM1-B	SPI0 SDO	I2C1 SCL	UART0 RTS	-	26	PWM5-A	SPI1 SCK	I2C1 SDA	UART1 CTS	ADC0	27	PWM5-B	SPI1 SDO	I2C1 SCL	UART1 RTS	ADC1	28	PWM6-A	SPI1 SDI	I2C0 SDA	UART0 TX	ADC2	29	PWM6-B	SPI1 CSn	I2C0 SCL	UART0 RX	ADC3
	GPIO	PWM	SPI	I2C	UART	Analog																																																	
	16	PWM0-A	SPI0 SDI	I2C0 SDA	UART0 TX	-																																																	
	17	PWM0-B	SPI0 CSn	I2C0 SCL	UART0 RX	-																																																	
	18	PWM1-A	SPI0 SCK	I2C1 SDA	UART0 CTS	-																																																	
	19	PWM1-B	SPI0 SDO	I2C1 SCL	UART0 RTS	-																																																	
	26	PWM5-A	SPI1 SCK	I2C1 SDA	UART1 CTS	ADC0																																																	
	27	PWM5-B	SPI1 SDO	I2C1 SCL	UART1 RTS	ADC1																																																	
	28	PWM6-A	SPI1 SDI	I2C0 SDA	UART0 TX	ADC2																																																	
29	PWM6-B	SPI1 CSn	I2C0 SCL	UART0 RX	ADC3																																																		
Servo Ports	Connectors for 8 x RC servo motors. Signal is connected to GP0, GP1, GP2, GP3, GP4, GP5, GP6, and GP7. For 5V, please refer to the 5V Supply section.																																																						
Maker Ports	JST-SH 4-Ways Connector for external modules. Compatible with Qwiic, STEMMA QT and Grove (Via Conversion Cable). These pins are available on Maker Ports: GP16, GP17, GP26, GP27, GP28 and GP29.																																																						
Motor Test Buttons	Press to test the functionality of the motor driver. Motor will run at full speed.																																																						
Motor Terminals	Connect to the motor terminal. Motor voltage at full speed is equal to power source voltage. Motor direction is dependent on the polarity.																																																						
Motor Status LEDs	Turn on when the motor is running.																																																						
USB Host	USB type A port for USB Host. The connected pins to USB data transmission on this port are:																																																						
	<table border="1" style="width: 100%; border-collapse: collapse; text-align: center;"> <thead> <tr style="background-color: #0056b3; color: white;"> <th>USB Pins</th> <th>GPIO</th> </tr> </thead> <tbody> <tr> <td>D+</td> <td>GP24</td> </tr> <tr> <td>D-</td> <td>GP25</td> </tr> </tbody> </table>	USB Pins	GPIO	D+	GP24	D-	GP25																																																
	USB Pins	GPIO																																																					
D+	GP24																																																						
D-	GP25																																																						

RGB LEDs	User programmable WS2812B RGB LEDs, NeoPixel compatible. Connected to GP23.
Piezo Buzzer	Can be used to play tone or melody. Connected to GP22.
Buzzer Mute Switch	Used to mute the piezo buzzer.
Measure VIN Jumper	Solder this jumper to measure VIN on the GP29(ADC3). <i>* Please be aware that the GPIO LED on GP29 will always turn on due to the high input from the VIN measurement.</i>

Table 1: MOTION 2350 Pro Board Functions

2. PINOUT DIAGRAM

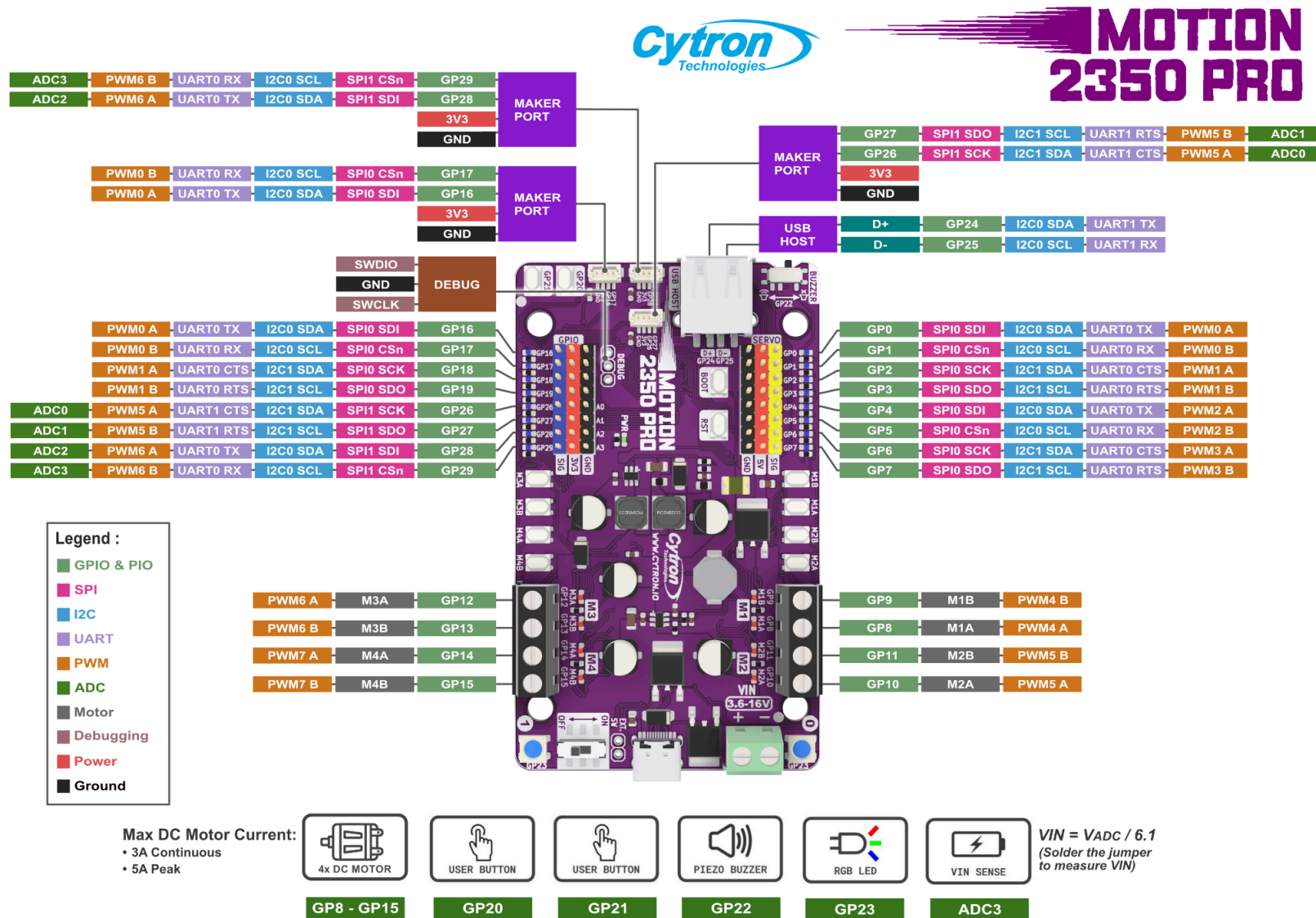

Figure 2: MOTION 2350 Pro Pinout Diagram

3. SPECIFICATIONS

No	Parameters	Min	Max	Unit	
1	Power Input Voltage (USB or VIN) *	3.6	16	V	
2	Digital Input Voltage	Low Level	-0.3	0.8	V
		High Level	2.0	3.6	V
3	Digital Output Voltage	Low Level	0	0.5	V
		High Level	2.6	3.3	V
4	Analog Input Voltage	0	3.3	V	
5	Vmotor (Only USB is connected)	VUSB - 0.4		V	
6	Vmotor (Only VIN is connected)	VIN		V	
7	Vmotor (USB and VIN are connected)	VIN < VUSB	VUSB - 0.4	V	
		VIN > VUSB and VIN - VUSB < 0.6	VIN - 0.4	V	
		VIN - VUSB > 0.6	VIN	V	
8	5V Output Voltage (Servo Ports)	VIN > 5.8V	5	V	
		VIN < 5.5V	VIN	V	
9	USB Host Output Voltage	-	5	V	
10	USB Host Output Current	-	500	mA	
11	Maximum DC Motor Current each Channel	Continuous	-	3	A
		Peak (< 5 seconds)	-	5	A
12	DC Motor Driver PWM Frequency	-	20	kHz	
13	Total +3V3 Output Current (GPIO Breakout & Grove Ports)	-	200	mA	
14	Total +5V Output Current (Servo Ports)	VIN < 5.8V	-	3	A
		VIN > 5.8V	-	2	A
15	Operating Temperature	-20	85	°C	

Table 2: MOTION 2350 Pro Absolute Maximum Ratings

* It's not recommended to connect both USB and VIN at the same time.
 Although it's perfectly safe to do so.

5V Port Automatic Voltage Selector

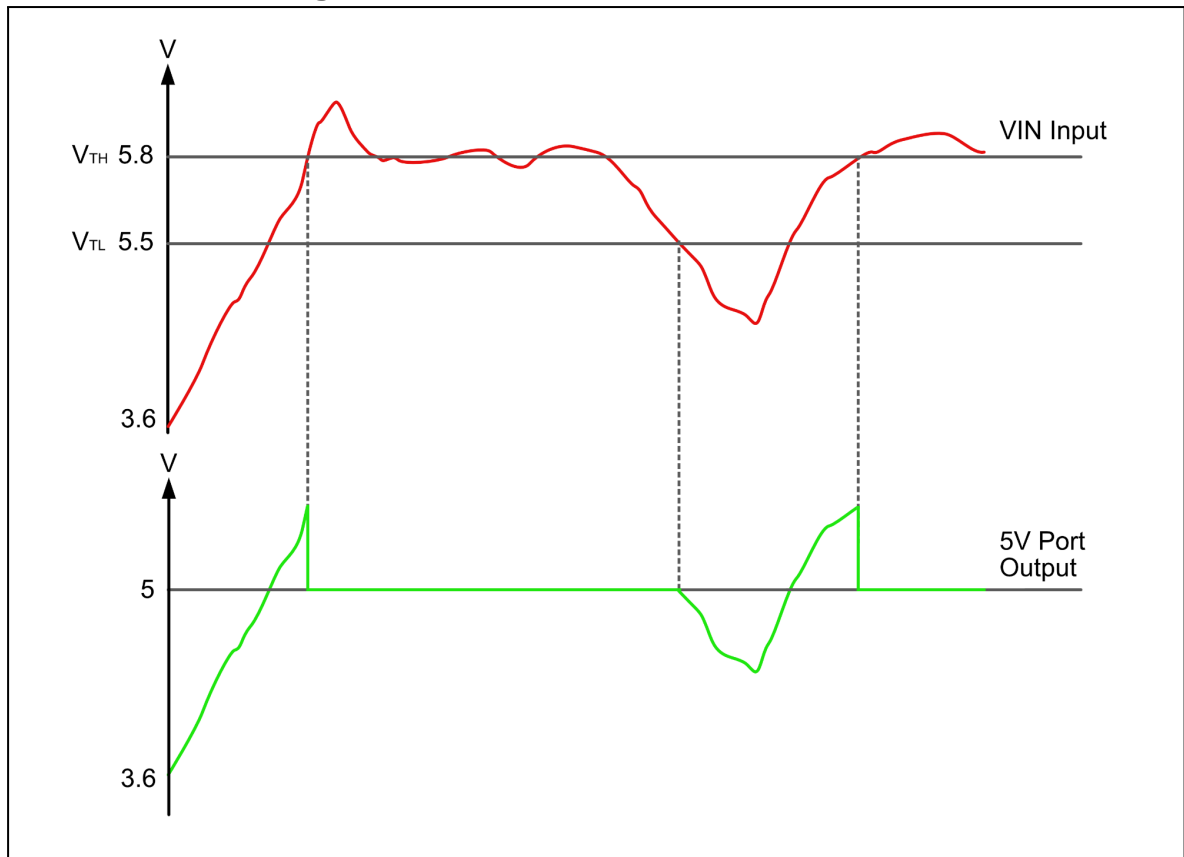

Figure 3: 5V Port Automatic Voltage Selector

The 5V port output is controlled by Schmitt Trigger to automatically control the output voltage on the 5V port output. It is to protect the servo and provide stable output voltage. When the VIN input voltage more than the high threshold voltage V_{TH} 5.8V, it will switch the output to an internal buck converter 5V. Will retain the 5V output until it reaches the low threshold voltage V_{TL} 5.5V.

4. DIMENSION

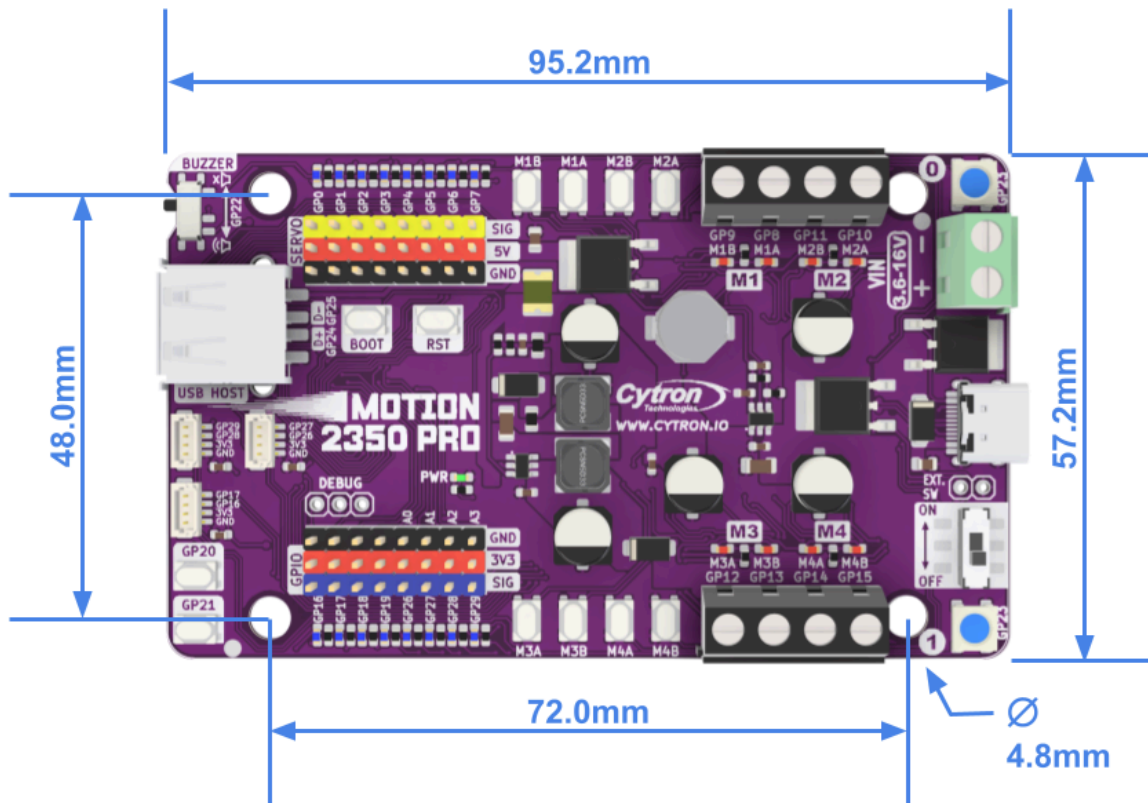

Figure 4: MOTION 2350 Pro Dimension

5. INTERFACE

Motor Driver

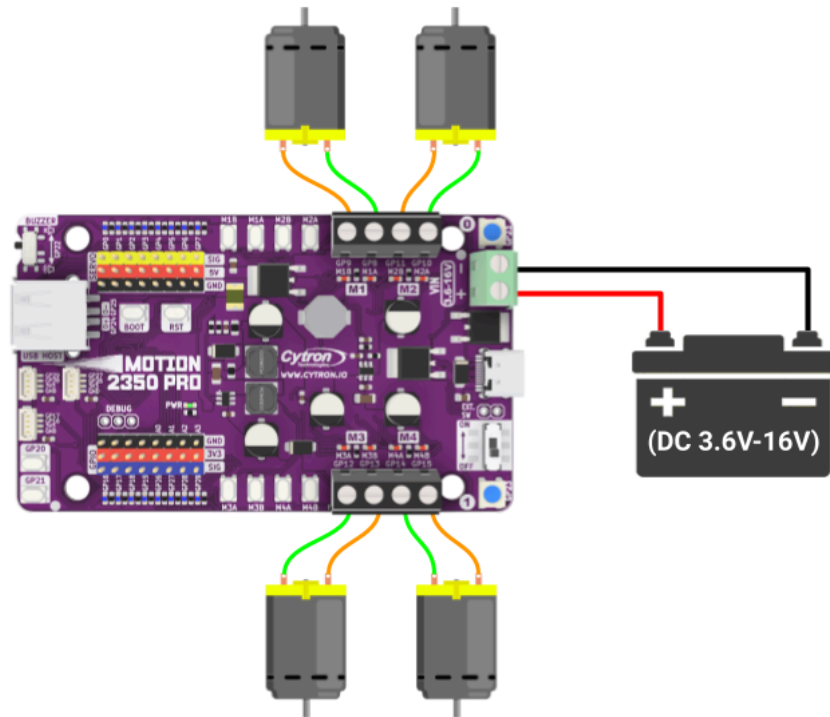

Figure 5: Connection Diagram for Brushed DC Motor

- * Actual motor direction is depending on the motor connection.
Swapping the connection (MA & MB) will reverse the direction.
- * The motor driver do not have overcurrent protection, please be aware with the max current rating on the motor. Overdraw the current can damage the motor driver.

Input Voltage Measurement

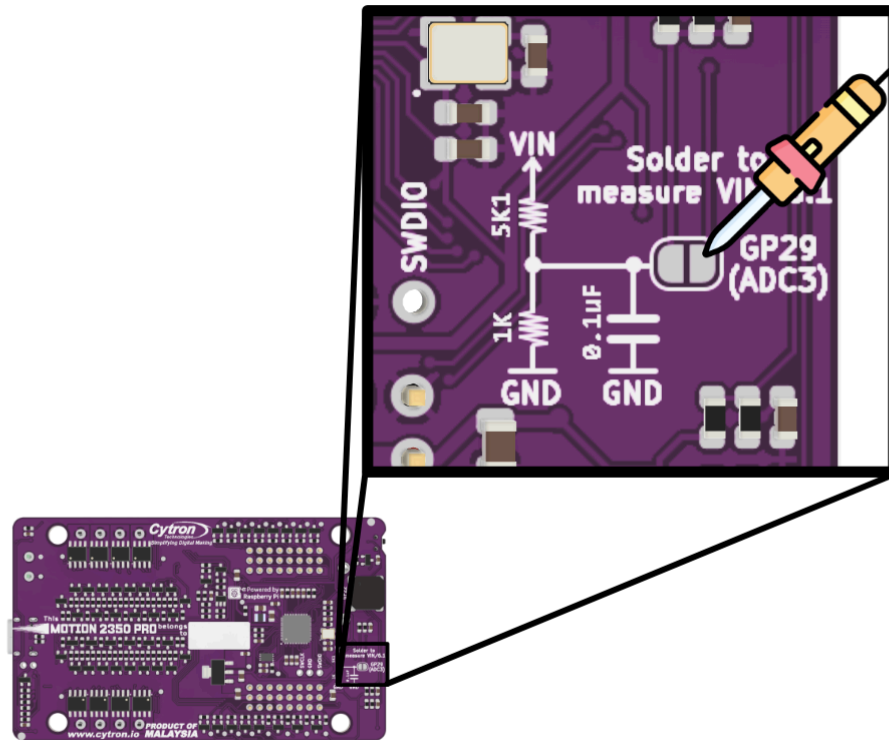

Figure 6: Solder to measure the VIN

Calculate the VIN on the GP29(ADC3) using this formula:

$$V_{IN} = V_{ADC} / 6.1$$

Where:

V_{IN} = VIN input terminal or VUSB input voltage (whichever is higher).

V_{ADC} = The ADC input voltage after converted from raw input data.

6. IMPORTANT NOTES

RP2350 GPIO Pull-Down Issue (Errata E9)

The RP2350 IC has a known hardware issue (Errata E9) affecting its General-Purpose Input/Output (GPIO) pins. When a GPIO pin is configured as an input with the internal pull-down resistor enabled, it exhibits a bus-hold-like behavior. After receiving a high input, the pin fails to properly pull down to 0V and instead retains a voltage of approximately 2.15V. It also happens even if the internal pull-down is disabled and an external pull-down is used (if the resistor value is too high).

To mitigate this issue, implement external pull-down resistors with a value less than 8k Ohms for each used pin.

Caution: This equipment is not intended for use in residential environments and might not provide adequate protection to radio reception in such environments.

Prepared by:

Cytron Technologies Sdn Bhd

www.cytron.io

No. 1, Lorong Industri Impian 1,
Taman Industri Impian,
14000 Bukit Mertajam,
Penang, Malaysia.

Tel: +604 - 548 0668

Fax: +604 - 548 0669

Email:

support@cytron.io

sales@cytron.io