

**■Features**

- High Radiant Power LEDs
- 5mm Round Standard Directivity
- UV Resistant Epoxy
- Pale red brown Color Transparent Type

**■Applications**

- IrDA
- Encoder
- Data Communication

**■Outline Dimension**

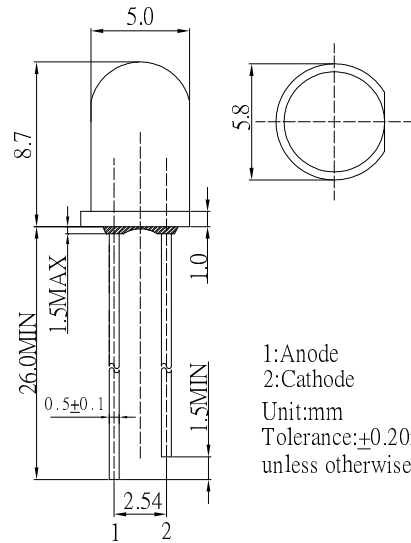

1: Anode  
2: Cathode  
Unit: mm  
Tolerance:  $\pm 0.20$  mm  
unless otherwise noted

**■Absolute Maximum Rating**

( $T_a=25^\circ\text{C}$ )

Item	Symbol	Value	Unit
DC Forward Current	$I_F$	100	mA
Pulse Forward Current#	$I_{FP}$	1000	mA
Reverse Voltage	$V_R$	5	V
Power Dissipation	$P_D$	180	mW
Operating Temperature	$T_{opr}$	-30 ~ +85	$^\circ\text{C}$
Storage Temperature	$T_{stg}$	-40 ~ +100	$^\circ\text{C}$
Lead Soldering Temperature	$T_{sol}$	260 $^\circ\text{C}$ /5sec	-

# Pulse Width  $\leq 100\mu\text{s}$ , Duty  $\leq 1/100$

**■Directivity**

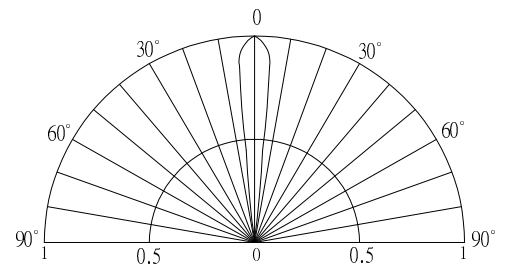

**■Electrical -Optical Characteristics**

( $T_a=25^\circ\text{C}$ )

Item	Symbol	Condition	Min.	Typ.	Max.	Unit
DC Forward Voltage*1	$V_F$	$I_F=100\text{mA}$	-	1.35	1.6	V
DC Reverse Current	$I_R$	$V_R=5\text{V}$	-	-	10	$\mu\text{A}$
Peak Wavelength*2	$\lambda_p$	$I_F=50\text{mA}$	-	940	-	nm
Radiant Power*3	$P_o$	$I_F=50\text{mA}$	-	12	-	mW
Radiant Intensity*4	$I_e$	$I_F=50\text{mA}$	35	55	-	mW/Sr
50% Power Angle	$2\theta_{1/2}$	$I_F=50\text{mA}$	-	15	-	deg

\*1 Tolerance of measurements of forward voltage is  $\pm 0.1\text{V}$

\*2 Tolerance of measurements of peak wavelength is  $\pm 1\text{nm}$

\*3 Tolerance of measurements of Radiant Power is  $\pm 15\%$

\*4 Tolerance of measurements of Radiant Intensity is  $\pm 15\%$

**AlGaAs LED**

**TYPICAL ELECTRICAL/OPTICAL CHARACTERISTIC CURVES**

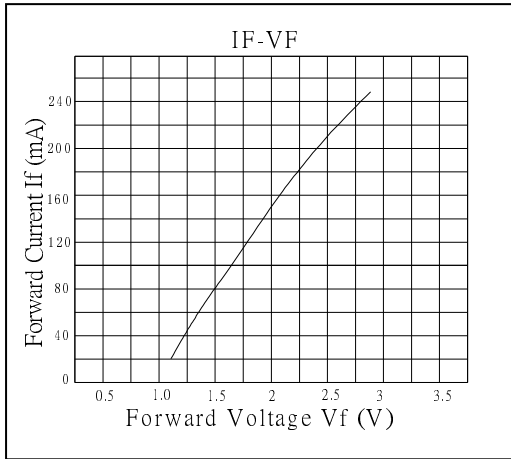

vs. Forward DC Current

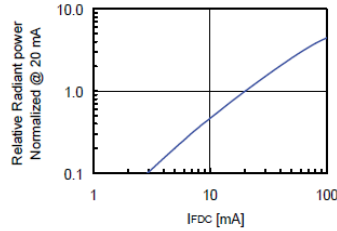

Vs. Forward Peak Current

