



SPL (HONG KONG) LIMITED

香港九龍觀塘鴻圖道57號南洋廣場17樓1703B室
Room 1703B, 17/F., Nanyang Plaza, No.57 Hung To Road, Kwun Tong, Kowloon, HK.
Tel: 852-2342 6857 / 2342 6867 Fax: 852-2342 6847 Email: sales@spl-hk.com.hk
Website: www.buzzer.com.hk ; www.transducer.com.hk ; www.connector.com.hk



ISO 9001:2008
Management
System
ID 9105074689

External Drive Piezo Transducer SPT15 series

DIMENSIONS

Date : 02 Jun.,2020

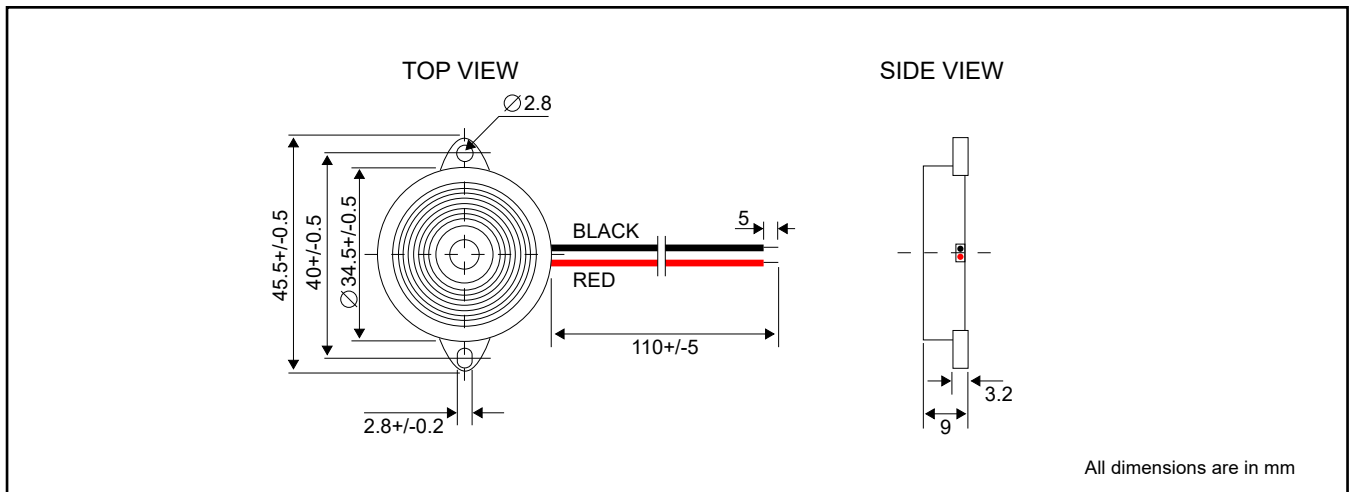

Ref. no. : P123078-R2



ELECTRICAL SPECIFICATIONS

Model No.	PT15-350912SAWR
Sound Pressure Level	85 dBA min. [9 Vp-p square wave, 10cm, 1200Hz]
Capacitance	50000 pF +/- 30% at 120Hz
Max. Input Voltage	30 Vp-p
Operating Temperature [°C]	-20 ~ +70
Storage Temperature [°C]	-20 ~ +70
Terminal	Wire - UL1007 AWG#28
Housing Material	ABS
Housing Colour	Black
Weight [gm]	5