



SK1816M

LINEAR INTEGRATED CIRCUIT

BIPOLAR LATCH TYPE HALL EFFECT FOR HIGH-TEMPERATURE OPERATION

DESCRIPTION

The UTC **SK1816M** is a semiconductor integrated circuit utilizing the Hall effect. It designed to operate in the alternating magnetic field especially at low supply voltage and operation over extended temperature ranges to +125°C.

This Hall IC is suitable for application to various kinds of sensors, contact-less switches, such as Speed sensor, Position sensor, Rotation sensor, Contact-less sensor, and Motor control.

FEATURES

- * Wide Temperature Operation Range of -30°C ~ +125°C
- * Alternating Magnetic Field Operation
- * TTL and MOS IC are Directly Drivable by the Output
- * The life is Semi Permanent because it Employs Contact-Less Parts
- * SIP-3 and SOT-23 Package are Available.

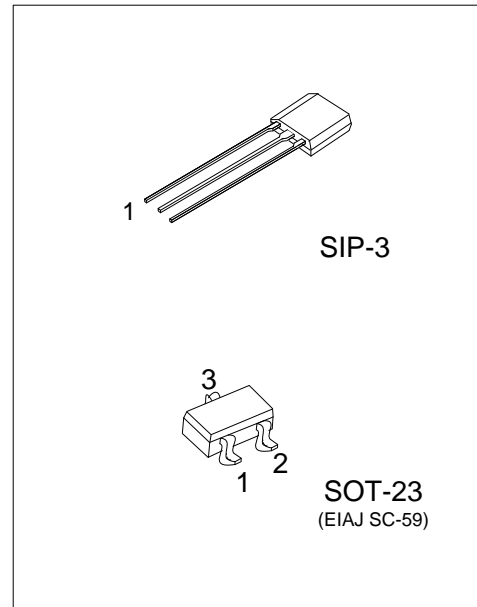

ORDERING INFORMATION

Ordering Number		Package	Pin Assignment			Packing
Lead Free	Halogen Free		1	2	3	
SK1816ML-AE3-R	SK1816MG-AE3-R	SOT-23	I	O	G	Tape Reel
SK1816ML-G03-B	SK1816MG-G03-B	SIP-3	I	G	O	Tape Box
SK1816ML-G03-K	SK1816MG-G03-K	SIP-3	I	G	O	Bulk

Note: Pin Assignment: I: V_{CC} O: V_{OUT} G: GND

<p>SK1816MG-AE3-R</p> <p>(1) Packing Type (2) Package Type (3) Green Package</p>	<p>(1) R: Tape Reel, B: Tape Box, K: Bulk (2) AE3: SOT-23, G03: SIP-3 (3) G: Halogen Free and Lead Free, L: Lead Free</p>
--	---

MARKING

SIP-3	SOT-23
<p>1816M □ □ □ → Date Code</p>	<p>1816M</p>

■ BLOCK DIAGRAM

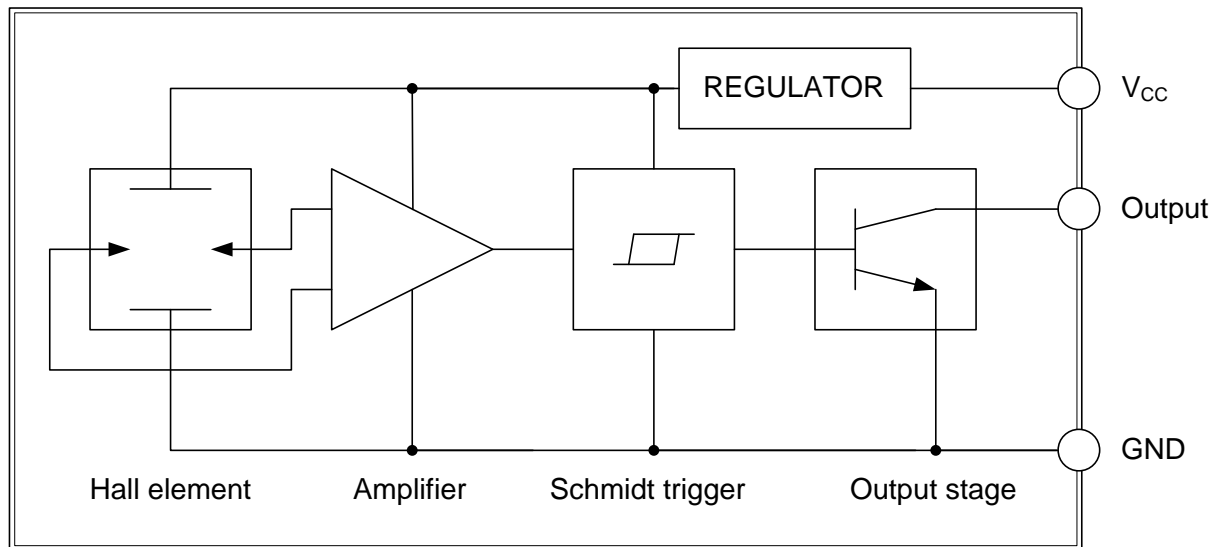

■ **ABSOLUTE MAXIMUM RATINGS** ($T_A=25^\circ\text{C}$, unless otherwise specified)

PARAMETER		SYMBOL	RATINGS	UNIT
Supply Voltage		V_{CC}	3.6 ~ 20	V
Supply Current		I_{CC}	6	mA
Circuit Current		I_o	20	mA
Power Dissipation	SIP-3	P_D	400	mW
	SOT-23		200	mW
Operating Temperature		T_{OPR}	-30 ~ +125	$^\circ\text{C}$
Storage Temperature		T_{STG}	-40 ~ +150	$^\circ\text{C}$

Note: Absolute maximum ratings are those values beyond which the device could be permanently damaged. Absolute maximum ratings are stress ratings only and functional device operation is not implied.

■ **ELECTRICAL CHARACTERISTICS** ($T_A=25^\circ\text{C}$, unless otherwise specified)

PARAMETER	SYMBOL	TEST CONDITIONS	MIN	TYP	MAX	UNIT
Low-Level Output Voltage	V_{OL}	$V_{CC}=16\text{V}$, $I_{OUT}=12\text{mA}$, $B=30\text{mT}$		0.2	0.7	V
		$V_{CC}=3.6\text{V}$, $I_{OUT}=12\text{mA}$, $B=30\text{mT}$		0.3	0.7	V
Output Leakage Current	I_{LEAK}	$V_{CC}=16\text{V}$, $B=-30\text{mT}$		1	10	μA
Supply Current	I_{CC}	$V_{CC}=16\text{V}$		3.5	6	mA
		$V_{CC}=3.6\text{V}$		3	6	mA
Output Switching Time	T_R	$V_{CC}=16\text{V}$, $R_L=10\text{K}\Omega$, $C_L=10\text{pF}$			5	μS
	T_F	$V_{CC}=16\text{V}$, $R_L=10\text{K}\Omega$, $C_L=10\text{pF}$			1	μS
MAGNETIC CHARACTERISTICS						
Operate Point	B_{OP}	At $T_A=25^\circ\text{C}$			5	mT
Release Point	B_{RP}	At $T_A=25^\circ\text{C}$			-5	mT
Hysteresis	B_{HYS}	At $T_A=25^\circ\text{C}$		5.5	10	mT

Notes: 1. B_{OP} =operate point (output turns ON); B_{RP} =release point (output turns OFF); B_{HYS} =hysteresis($B_{OP} - B_{RP}$).

As used here, negative flux densities are defined as less than zero (algebraic convention). Typical values are at $T_A=25^\circ\text{C}$ and $V_{CC}=12\text{V}$.

2. 1mT=10 gauss

PACKAGE INFORMATION

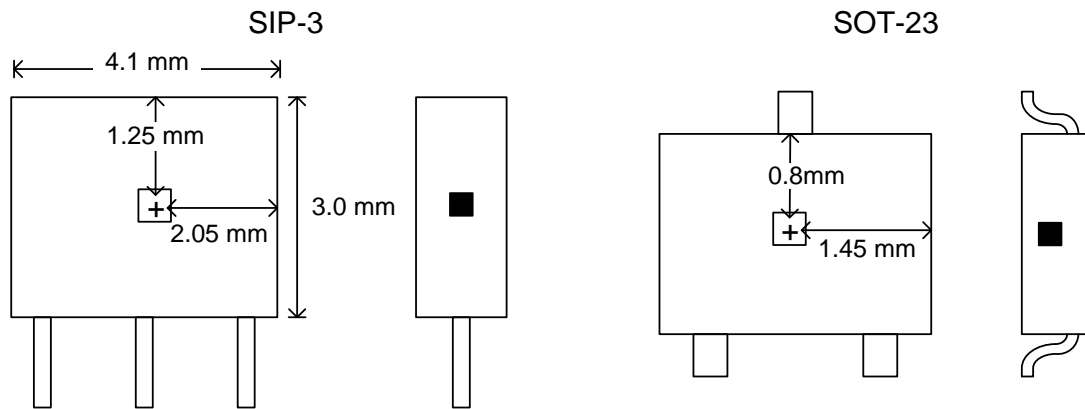

Fig. 1 SENSOR LOCATIONS

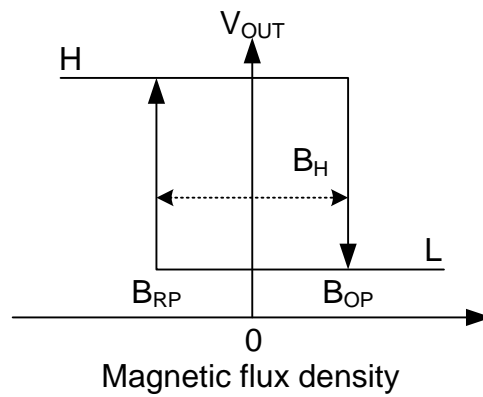
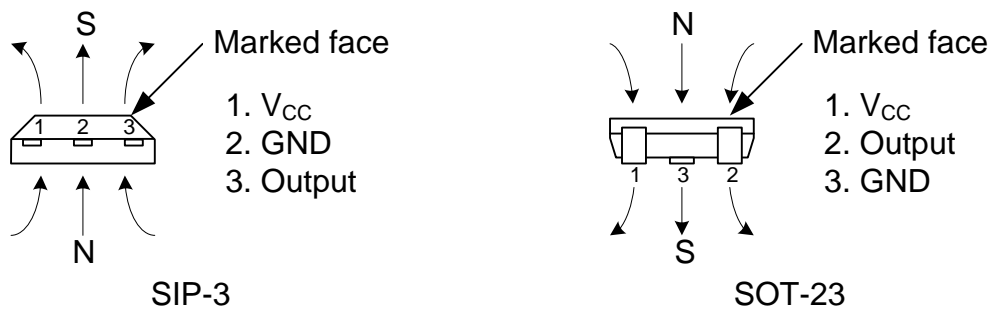
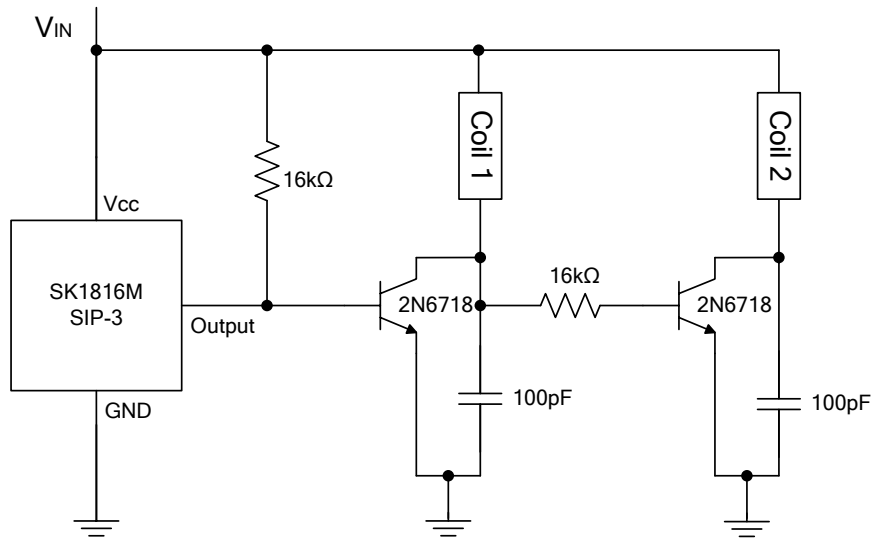
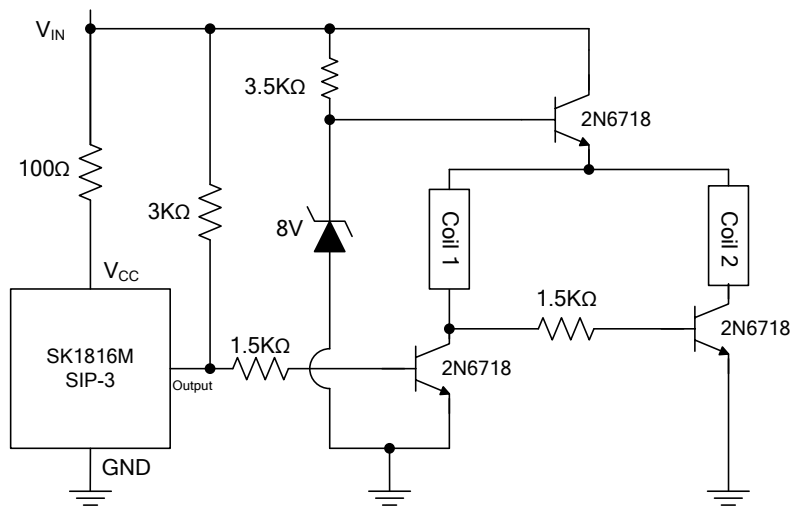

Fig. 2 APPLYING DIRECTION OF MAGNETIC FLUX

■ TYPICAL APPLICATION CIRCUIT



FOR DC FAN 1



FOR DC FAN 2

■ TEST CIRCUIT

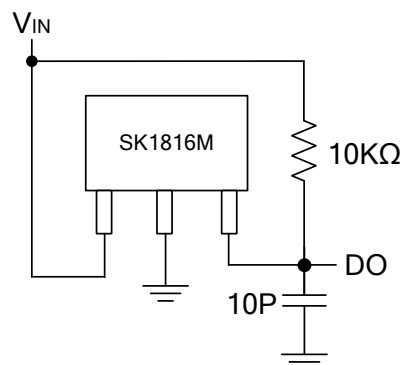

■ TYPICAL CHARACTERISTICS

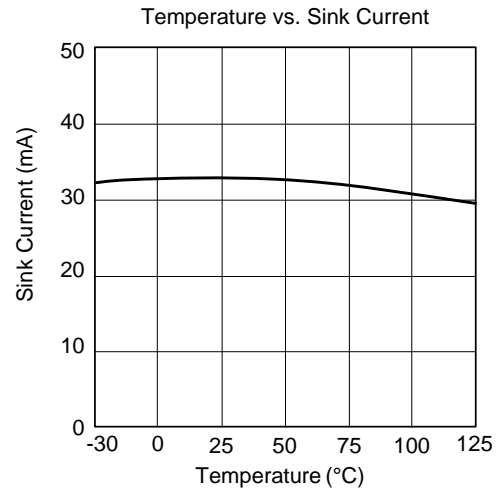
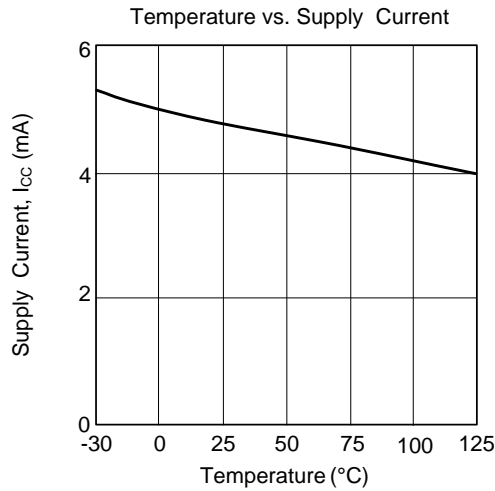

UTC assumes no responsibility for equipment failures that result from using products at values that exceed, even momentarily, rated values (such as maximum ratings, operating condition ranges, or other parameters) listed in products specifications of any and all UTC products described or contained herein. UTC products are not designed for use in life support appliances, devices or systems where malfunction of these products can be reasonably expected to result in personal injury. Reproduction in whole or in part is prohibited without the prior written consent of the copyright owner. UTC reserves the right to make changes to information published in this document, including without limitation specifications and product descriptions, at any time and without notice. This document supersedes and replaces all information supplied prior to the publication hereof.