

1 2 3 4 5 6 7 8 9 10

A
B
C
D
E
F
G

A
B
C
D
E
F
G

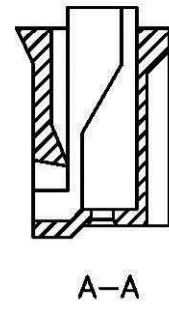
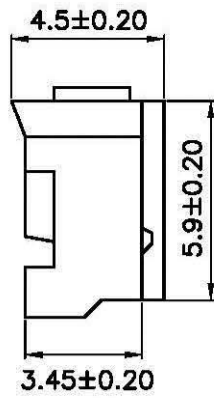
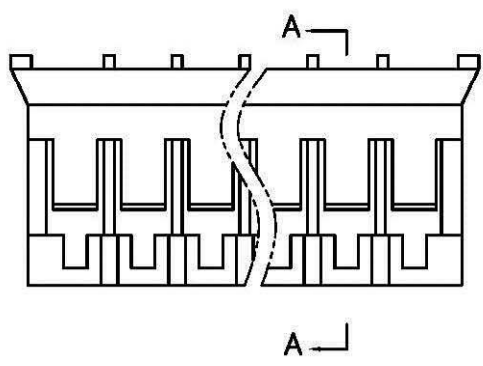
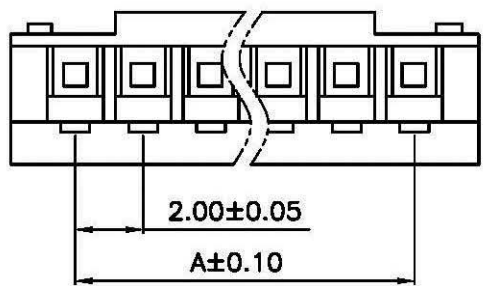
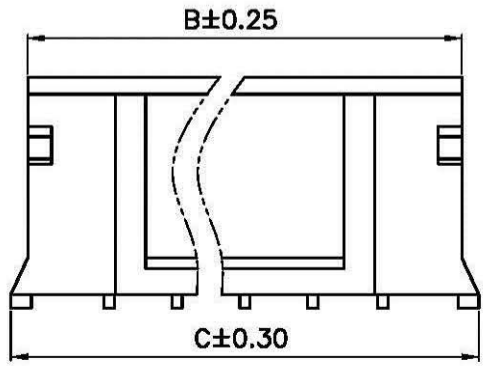

SPECIFICATIONS
 Voltage Rating: 100V AC/DC
 Current Rating: 2A AC/DC
 Withstanding Voltage: 800V AC/minute
 Insulation Resistance: 1,000MΩ min.
 Temperature Range: -25° C - +85° C
 Contact Resistance: 20mΩ max

HOUSING
 Poles: 2-16
 Material: Nylon 66, UL94V-2

| NO | DIMENSION | | |
|-----|-----------|-------|-------|
| | A | B | C |
| .02 | 2.00 | 4.60 | 5.80 |
| .03 | 4.00 | 6.60 | 7.80 |
| .04 | 6.00 | 8.60 | 9.80 |
| .05 | 8.00 | 10.60 | 11.80 |
| .06 | 10.00 | 12.60 | 13.80 |
| .07 | 12.00 | 14.60 | 15.80 |
| .08 | 14.00 | 16.60 | 17.80 |
| .09 | 16.00 | 18.60 | 19.80 |
| .10 | 18.00 | 20.60 | 21.80 |
| .11 | 20.00 | 22.60 | 23.80 |
| .12 | 22.00 | 24.60 | 25.80 |
| .13 | 24.00 | 26.60 | 27.80 |
| .14 | 26.00 | 28.60 | 29.80 |
| .15 | 28.00 | 30.60 | 31.80 |
| .16 | 30.00 | 32.60 | 33.80 |

| | | | | | | | | | | | | |
|-----|------|--------------------------|--------|---------|--|---------------|---------|--|--|-------|-----|-------------------------------------|
| | | | | | | OPERATION | DRAW | | | SCALE | | |
| | | | | | | ~ 10 ±0.15 | DESIGN | | | UNIT | mm | |
| | | | | | | 20 ~ 30 ±0.30 | CHECK | | | SIZE | A4 | PART NO. _____ DRAWING NO. _____ |
| 0 | | NEW | | | | 30 ~ ±0.50 | APPROVE | | | SHEET | 1/1 | |
| REV | DATE | MODIFICATION DESCRIPTION | CHANGE | APPROVE | | Angle ± 2' | | | | PROJ. | ◆ | |
| | | | | | | DIM TOL | | | | | | |

1 2 3 4 5 6 7 8 9 10

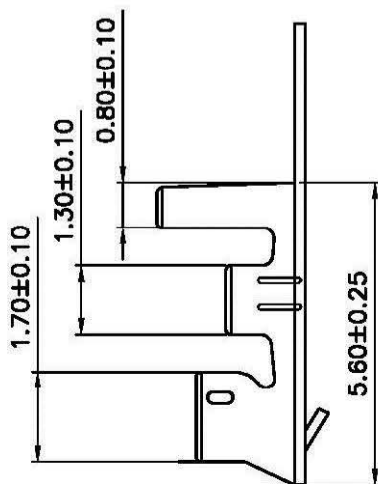
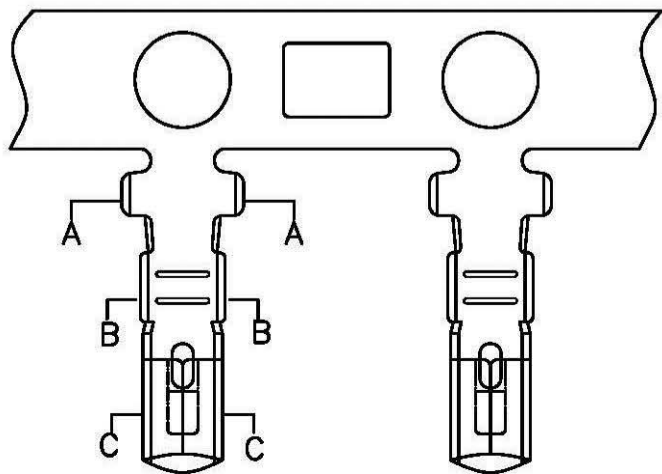

SPECIFICATIONS

Voltage Rating: 100V AC/DC
 Current Rating: 2A AC/DC
 Withstanding Voltage: 800V AC/minute
 Insulation Resistance: 1,000MΩ min.
 Temperature Range: -25° C - +85° C
 Contact Resistance: 20mΩ max

TERMINAL

Wire Range: AWG#22-#28 (OD1.5mm)
 Material: Phos. Bronze
 Finish: Tin Plated
 Thickness: 0.2mm
 Q'TY: 10,000PCS/Reel

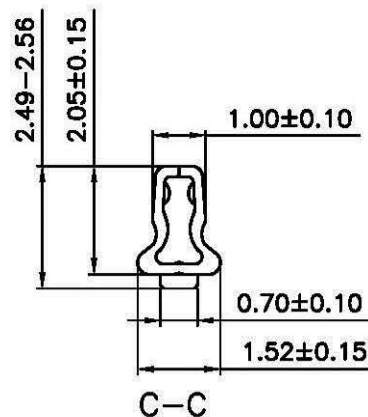
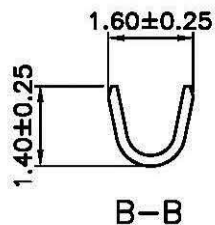
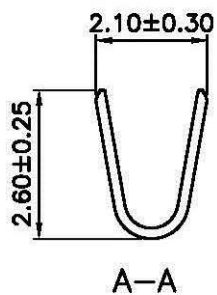

| | | | | | | | | | | | | | |
|-----|------|--------------------------|--|--|--------|---------------|---------|--|--|-------|-----|--------------------------------|----------|
| | | | | | | OPERATION | DRAW | | | SCALE | | Chang Enn Co., Ltd. | |
| | | | | | | ~ 10 ±0.15 | DESIGN | | | UNIT | mm | | |
| | | | | | | 20 ~ 30 ±0.30 | CHECK | | | SIZE | A4 | | |
| | | | | | | 30 ~ ±0.50 | APPROVE | | | SHEET | 1/1 | | PART NO. |
| 0 | | | | | | Angle ± 2' | | | | PROJ. | ↙ | DRAWING NO. | |
| REV | DATE | MODIFICATION DESCRIPTION | | | CHANGE | APPROVE | | | | | | | |

1 2 3 4 5 6 7 8 9 10

A
B
C
D
E
F
G

A
B
C
D
E
F
G

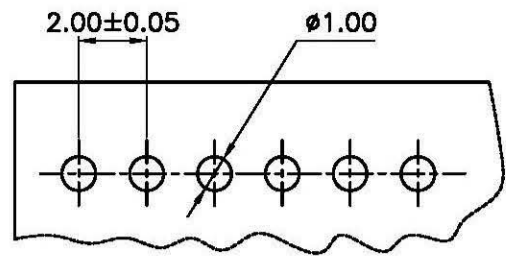
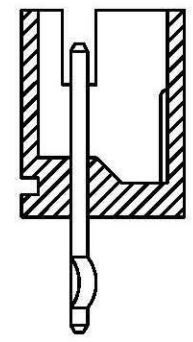
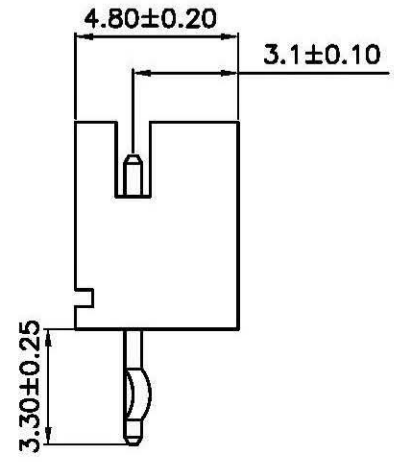
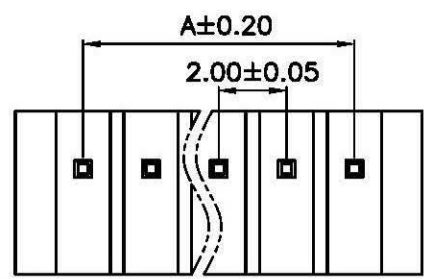
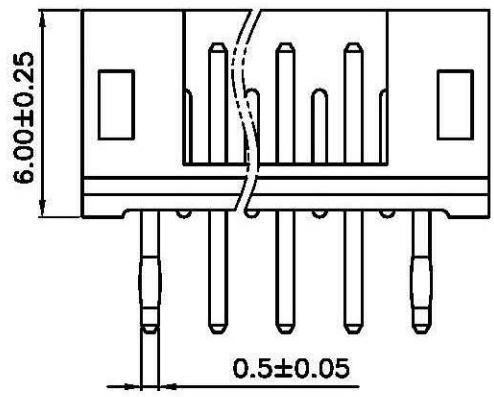
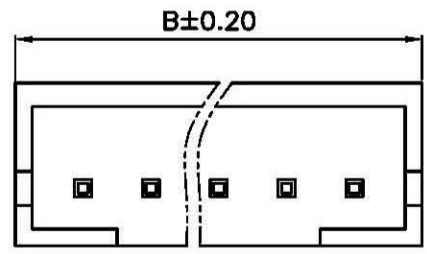

PCB LAYOUT

SPECIFICATIONS

Voltage Rating: 100V AC/DC
 Current Rating: 2A AC/DC
 Withstanding Voltage: 800V AC/minute
 Insulation Resistance: 1,000MΩ min.
 Temperature Range: -25° C - +85° C
 Contact Resistance: 20mΩ max

WAFER

Poles: 2-16
 Material: Nylon 66, UL94V-2
 Contact: Brass, Tin plated

| NO | DIMENSION | |
|----|-----------|-------|
| | A | B |
| 02 | 2.00 | 6.00 |
| 03 | 4.00 | 8.00 |
| 04 | 6.00 | 10.00 |
| 05 | 8.00 | 12.00 |
| 06 | 10.00 | 14.00 |
| 07 | 12.00 | 16.00 |
| 08 | 14.00 | 18.00 |
| 09 | 16.00 | 20.00 |
| 10 | 18.00 | 22.00 |
| 11 | 20.00 | 24.00 |
| 12 | 22.00 | 26.00 |
| 13 | 24.00 | 28.00 |
| 14 | 26.00 | 30.00 |
| 15 | 28.00 | 32.00 |
| 16 | 30.00 | 34.00 |

| | | | | | | | | | | | | | |
|-----|------|--------------------------|--------|---------|--|---------------|---------|--|--|-------|-----|-------------|----------|
| | | | | | | OPERATION | DRAW | | | SCALE | | | |
| | | | | | | ~ 10 ±0.15 | DESIGN | | | UNIT | mm | | |
| | | | | | | 20 ~ 30 ±0.30 | CHECK | | | SIZE | A4 | | |
| 0 | | NEW | | | | 30 ~ ±0.50 | APPROVE | | | SHEET | 1/1 | | PART NO. |
| REV | DATE | MODIFICATION DESCRIPTION | CHANGE | APPROVE | | Angle ± 2' | APPROVE | | | PROJ. | ◆ | DRAWING NO. | |
| | | | | | | Dim TOL | | | | | | | |

1 2 3 4 5 6 7 8 9 10