

STM32G4 Nucleo-32 board (MB1430)

Introduction

The STM32G4 Nucleo-32 board (NUCLEO-G431KB) provides an affordable and flexible way for users to try out new concepts and build prototypes, by choosing from the various combinations of performance, power consumption and features provided by the STM32G4 Series microcontroller. The ARDUINO® Nano V3 connectivity provides easy means of expanding the functionality of the Nucleo open development platform with a wide choice of specialized shields. The STM32G4 Nucleo-32 board does not require any separate probe as it integrates the STLINK-V3E debugger/programmer. The STM32G4 Nucleo-32 board comes with the comprehensive free software libraries and examples available with the STM32CubeG4 MCU Package.

Figure 1. NUCLEO-G431KB top view

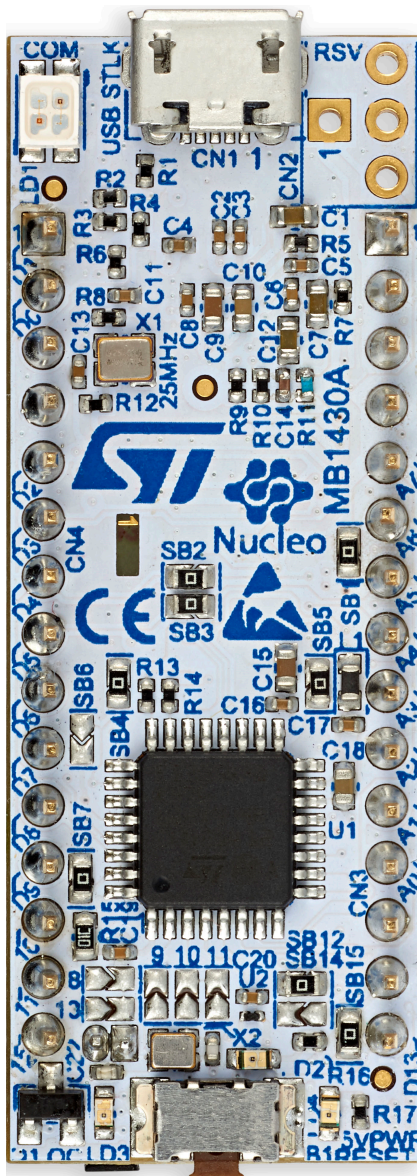
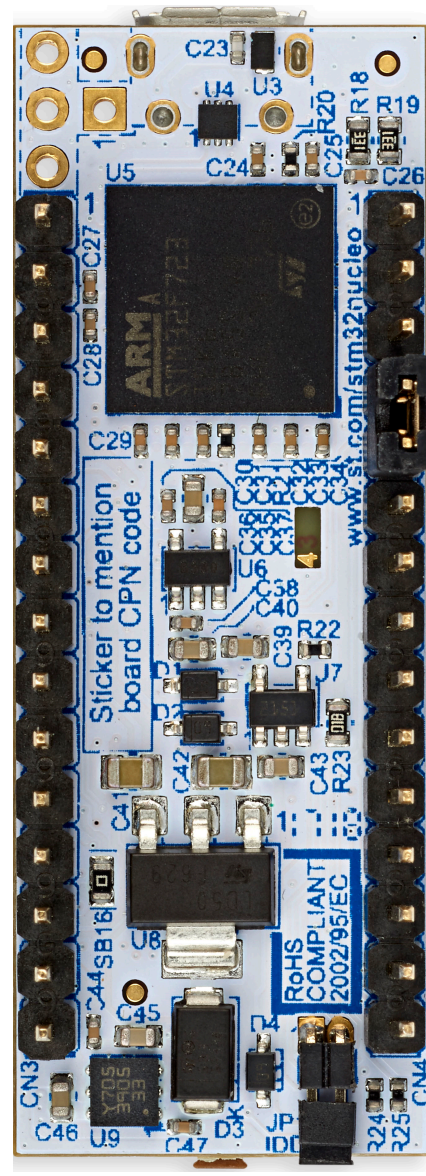

Figure 2. NUCLEO-G431KB bottom view



Pictures are not contractual.

1 Features

- STM32G4 microcontroller (Arm® Cortex®-M4 at 170 MHz) in UFQFPN32 package, featuring 128 Kbytes of Flash memory and 32 Kbytes of SRAM for STM32G431KBT6
- 1 user LED
- 1 RESET push button
- 24 MHz HSE crystal oscillator
- Board connectors:
 - USB with Micro-B
 - ARDUINO® Nano V3 expansion connector
- Flexible power-supply options: ST-LINK USB V_{BUS} or external sources
- On-board STLINK-V3E debugger/programmer with SWD connector:
 - USB re-enumeration capability: virtual COM port, mass storage, debug port
- Comprehensive free software libraries and examples available with the STM32Cube package

Note: Arm is a registered trademark of Arm Limited (or its subsidiaries) in the US and/or elsewhere.



2 Ordering information

To order the STM32G4 Nucleo-32 board, refer to [Table 1](#). Additional information is available from the datasheet and reference manual of the target STM32.

Table 1. Ordering information

Order code	Board reference	Target STM32
NUCLEO-G431KB	MB1430	STM32G431KBT6U

2.1 Product marking

Evaluation tools marked as “ES” or “E” are not yet qualified and therefore not ready to be used as reference design or in production. Any consequences deriving from such usage will not be at ST charge. In no event, ST will be liable for any customer usage of these engineering sample tools as reference design or in production.

“E” or “ES” marking examples of location:

- On the targeted STM32 that is soldered on the board (for illustration of STM32 marking, refer to the STM32 datasheet “Package information” paragraph at the www.st.com website).
- Next to the evaluation tool ordering part number that is stuck or silk-screen printed on the board.

This board features a specific STM32 device version, which allows the operation of any bundled commercial stack/library available. This STM32 device shows a “U” marking option at the end of the standard part number and is not available for sales.

In order to use the same commercial stack in his application, a developer may need to purchase a part number specific to this stack/library. The price of those part numbers includes the stack/library royalties.

2.2 Codification

The meaning of the codification is explained in [Table 2](#).

Table 2. Codification explanation

NUCLEO-XXYYKT	Description	Example: NUCLEO-G431KB
XX	MCU series in STM32 Arm Cortex MCUs	STM32G4 Series
YY	MCU product line in the series	STM32G431
K	STM32 package pin count	32 pins
B	STM32 Flash memory size: • B for 128 Kbytes	128 Kbytes

3 Development environment

3.1 System requirements

- Windows® OS (7, 8 and 10), Linux® 64-bit, or macOS®
- USB Type-A to Micro-B cable

Note: macOS® is a trademark of Apple Inc. registered in the U.S. and other countries.
All other trademarks are the property of their respective owners.

3.2 Development toolchains

- Keil® MDK-ARM (see [note](#))
- IAR™ EWARM (see [note](#))
- GCC-based IDEs

Note: On Windows® only.

3.3 Demonstration software

The demonstration software, included in the STM32Cube MCU Package corresponding to the on-board microcontroller, is preloaded in the STM32 Flash memory for easy demonstration of the device peripherals in standalone mode. The latest versions of the demonstration source code and associated documentation can be downloaded from www.st.com.

4 Conventions

Table 3 provides the conventions used for the ON and OFF settings in the present document.

Table 3. ON/OFF convention

Convention	Definition
Jumper JPx ON	Jumper fitted
Jumper JPx OFF	Jumper not fitted
Jumper JPx [1-2]	Jumper should be fitted between Pin 1 and Pin 2
Solder bridge SBx ON	SBx connections closed by 0 Ω resistor
Solder bridge SBx OFF	SBx connections left open
Resistor Rx ON	Resistor soldered
Resistor Rx OFF	Resistor not soldered

5 Quick start

The STM32G4 Nucleo-32 board is a low-cost and easy-to-use development kit, used to evaluate and start a development quickly with an STM32G4 Series microcontroller in LFQFPN 32-pin package. Before installing and using the product, accept the Evaluation Product License Agreement from the www.st.com/epla webpage. For more information on the STM32G4 Nucleo-32 and for demonstration software, visit the www.st.com/stm32nucleo webpage.

5.1 Getting started

Follow the sequence below to configure the STM32G4 Nucleo-32 board and launch the demonstration application (refer to [Figure 4](#) for component location):

1. Check the jumper position on the board (refer to [Table 4](#)).
2. For the correct identification of the device interfaces from the host PC and before connecting the board, install the Nucleo USB driver available on the www.st.com/stm32nucleo website.
3. To power the board, connect the STM32G4 Nucleo-32 board to a PC with a USB cable (Type-A to Micro-B) through the USB connector CN1 of the board.
4. Then, LED LD1 (COM) and green LED LD4 (5V_PWR) light up, green LED LD2 blinks.
5. Remove the jumper placed between D2 (CN4 pin 5) and GND (CN4 pin 4).
6. Observe how the blinking of the green LED LD2 changes, when the jumper is in place or removed.
7. Download the software demonstration software and several software examples that help to use the STM32 Nucleo features. These are available on the [NUCLEO-G431KB](#) webpage
8. Develop your own application using the available examples

Table 4. Jumper configuration

Jumper	Definition	Position(1)	Comment(1)
JP1	IDD	ON	For STM32G4 current measurements

1. *Default jumper state is in bold.*

6 Hardware layout and configuration

The STM32G4 Nucleo-32 board is designed around the STM32 microcontrollers in a 32-pin UFQFPN package. [Figure 3](#) shows the connections between the STM32 and its peripherals (STLINK-V3E, push button, LEDs, USB and Arduino Nano). [Figure 4](#) and [Figure 5](#) show the location of these features on the STM32G4 Nucleo-32 board. The mechanical dimensions of the board are shown in [Figure 6](#).

Figure 3. Hardware block diagram

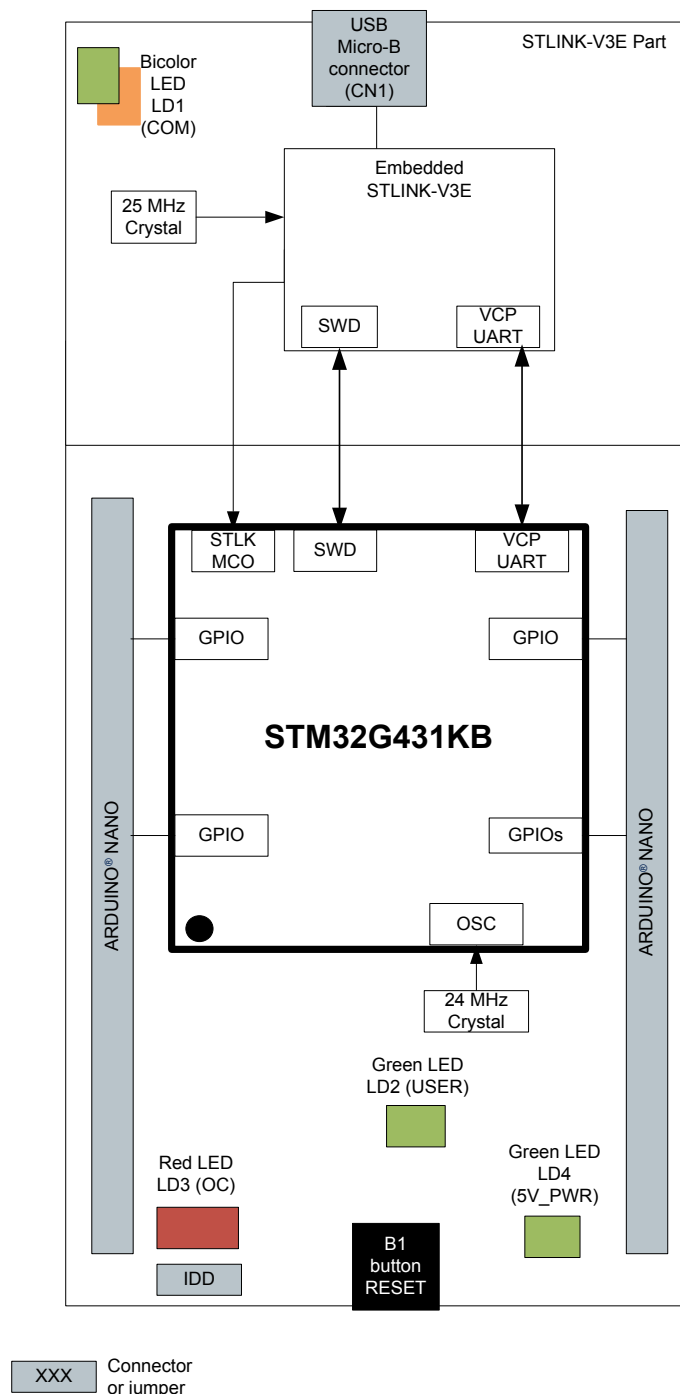

6.1 PCB layout

Figure 4. Top layout

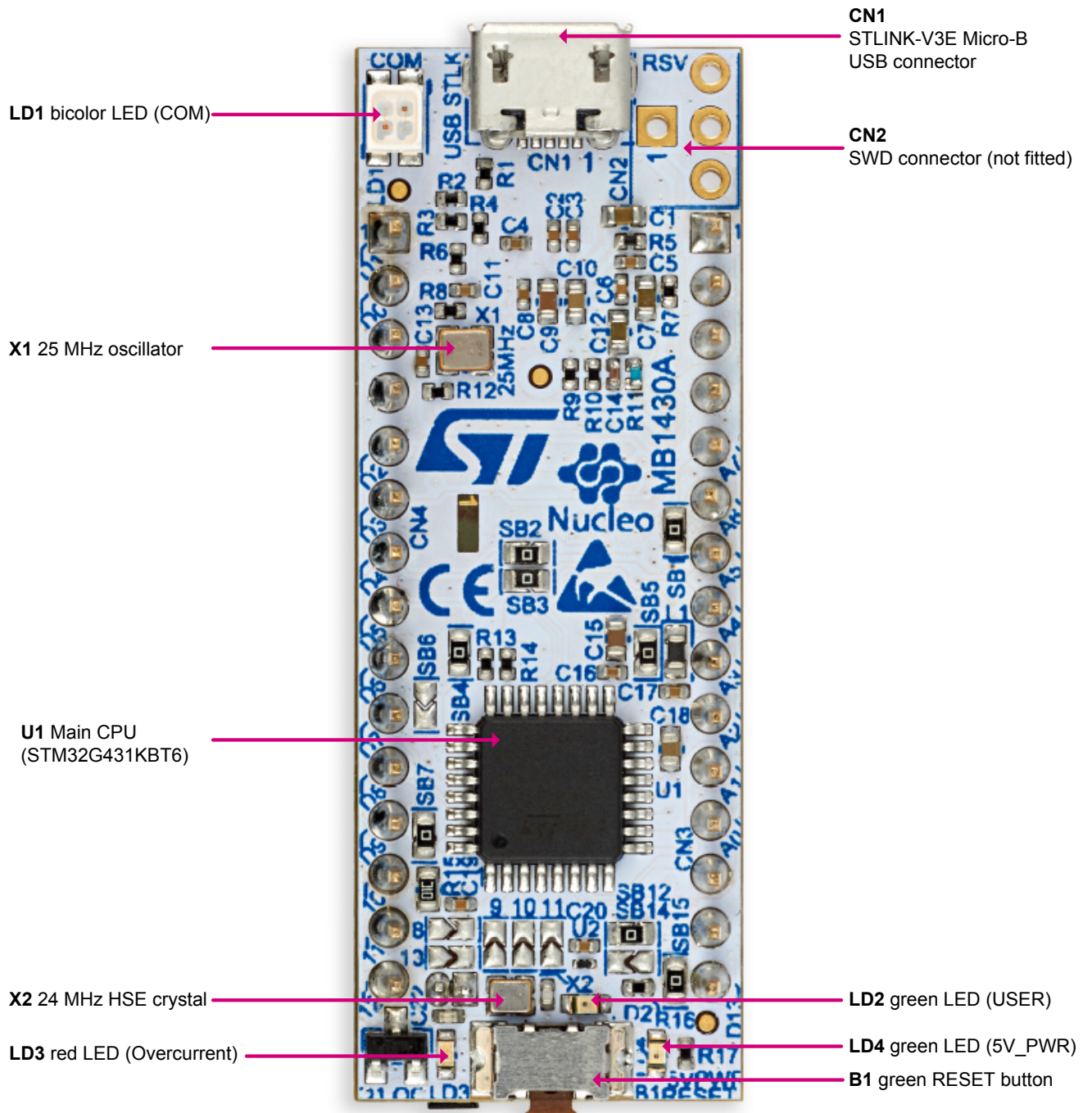
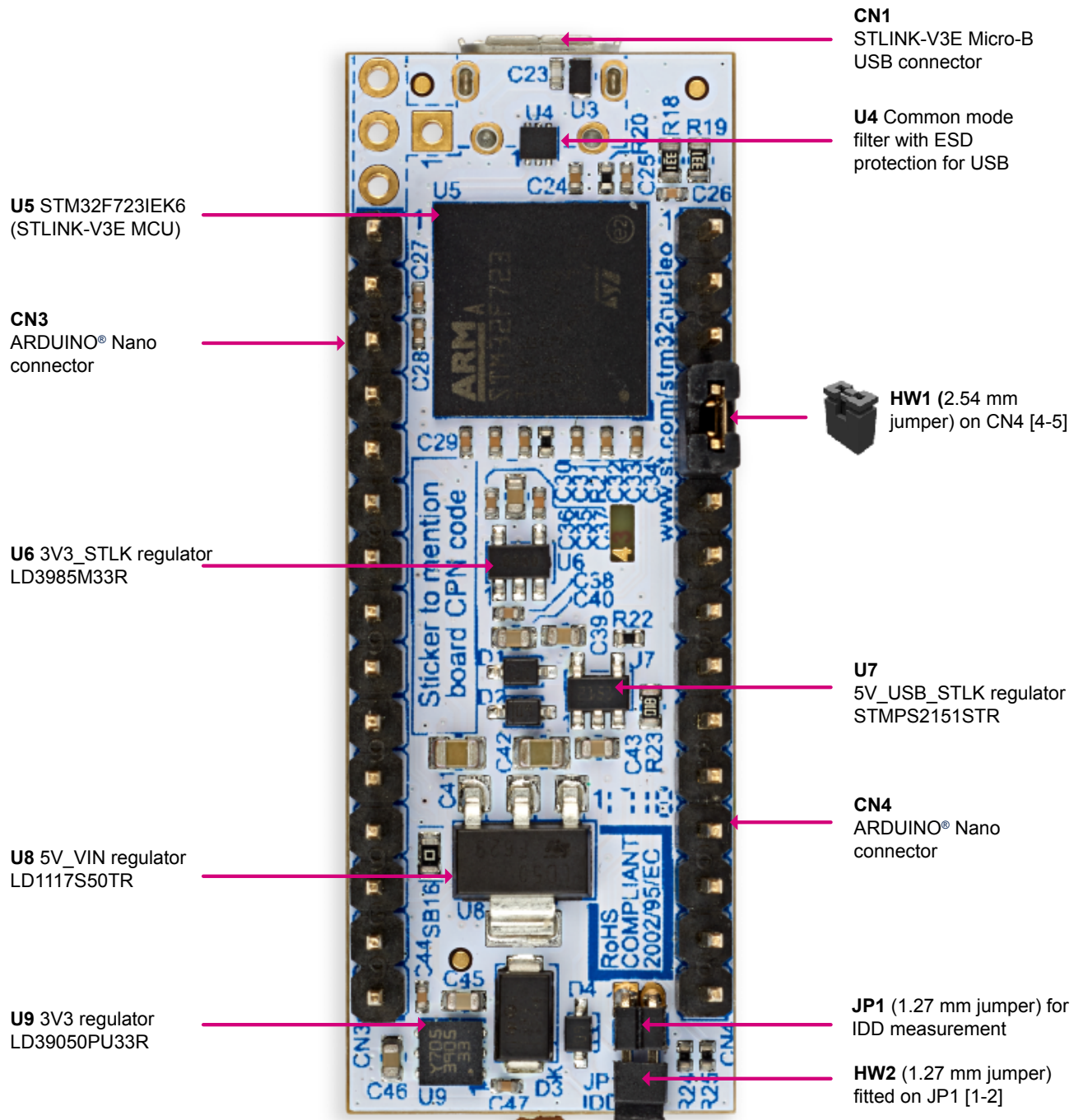
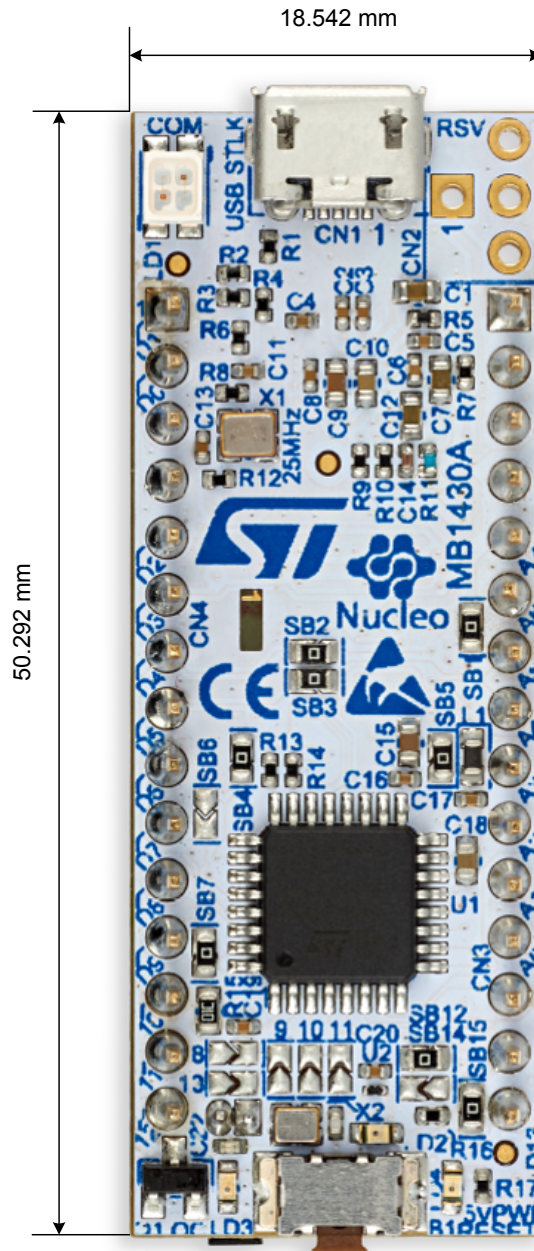

Figure 5. Bottom layout



6.2 Mechanical drawing

Figure 6. STM32G4 Nucleo 32 board mechanical drawing (in millimeter)



6.3 Embedded STLINK-V3E

The way to program and debug the onboard STM32 MCU is by using the embedded STLINK-V3E.

The STM32G4 Nucleo-32 integrates the STLINK-V3E programming and debugging tool.

The embedded STLINK-V3E supports only SWD and VCP for STM32 devices. For information about debugging and programming features, refer to the *STLINK-V3SET debugger/programmer for STM8 and STM32* user manual (UM2448), which describes in details all the STLINK-V3E features.

Features supported on STLINK-V3E:

- 5V power supplied by USB connector (CN1)
- USB 2.0 high-speed-compatible interface
- Serial wire debugging (SWD) specific features:
 - 3 V to 3.6 V application voltage on the SWD interface and 5 V tolerant inputs
 - Serial viewer (SWV) communication
- Status LD1 LED (COM), blinking during communication with the PC
- Fault red LED LD3 (OC), alerting on USB overcurrent request
- 5 V / 300 mA output power supply capability (U4), with current limitation and LED
- 5 V power green LED LD4 (5V_PWR)

6.3.1 Drivers

Before connecting the STM32G4 Nucleo-32 board to a Windows PC via USB, the user must install a driver for the STLINK-V3E (not required for Windows 10). It is available at the www.st.com website.

In case the STM32G4 Nucleo-32 board is connected to the PC before the driver is installed, some STM32G4 Nucleo-32 interfaces may be declared as “Unknown” in the PC device manager. In this case, the user must install the dedicated driver files, and update the driver of the connected device from the device manager as shown in Figure 7.

Note: Prefer using the USB Composite Device handle for a full recovery.

Figure 7. USB composite device

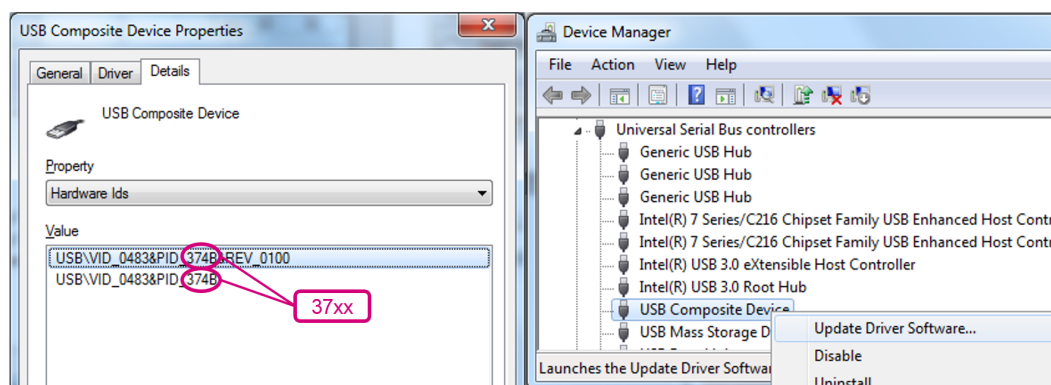

Note: 37xx:

- 374E for STLINK-V3E without bridges functions
- 374F for STLINK-V3E with bridges functions

6.3.2 STLINK-V3E firmware upgrade

The STLINK-V3E embeds a firmware upgrade mechanism for in-situ upgrade through the USB port. As the firmware may evolve during the lifetime of the STLINK-V3E product (for example new functionalities, bug fixes, support for new microcontroller families), it is recommended to visit the www.st.com website before starting to use the STM32G4 Nucleo-32 board and periodically, to stay up-to-date with the latest firmware version.

6.4 Power supply

Five different sources can provide the power supply:

- **A host PC connected to CN1 through a USB cable (default setting)**
- An external 5 V USB charger (5V_USB_CHGR) connected to CN1
- An external 7 V - 12 V (VIN) power supply connected to CN3 pin 1
- An external 3.3 V power supply (3V3) connected to CN3 pin 14
- An external 5 V power supply (5V) connected to CN3 pin 4

Figure 8. STM32G4 Nucleo-32 board power tree

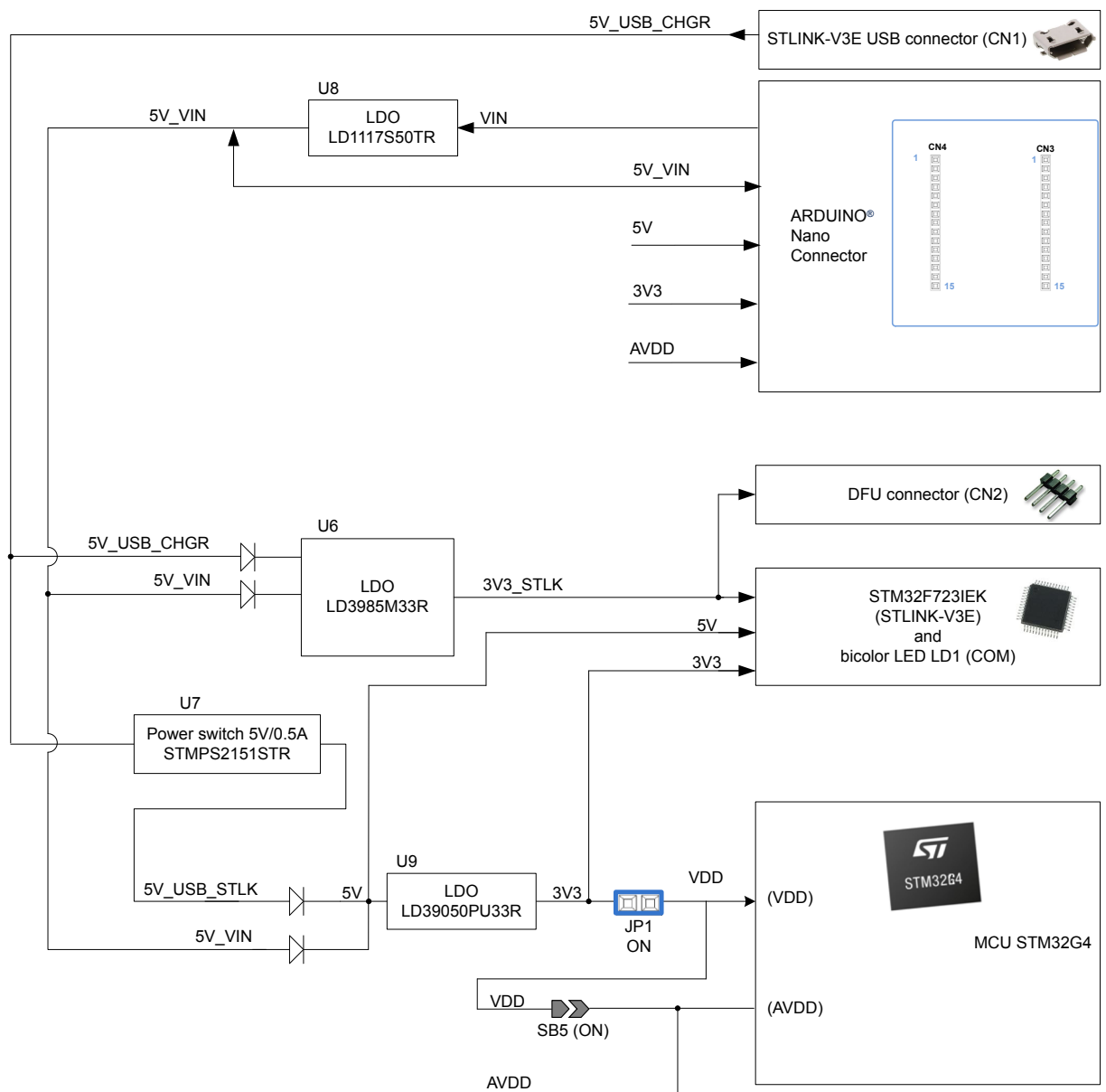

In case VIN, 5V or 3V3 is used to power the STM32G4 Nucleo-32 board, this power source must comply with the EN-60950-1: 2006+A11/2009 standard and must be Safety Extra Low Voltage (SELV) with limited power capability.

If the power supply is 3V3 or 5V, the ST-LINK is not powered and cannot be used.

1) Power supply input from STLINK-V3E USB connector (default setting)

The STM32G4 Nucleo-32 board and shield can be powered from STLINK-V3E connector CN1 (5 V).

If the USB enumeration succeeds, the 5V_USB_STLK power is enabled, by asserting the T_PWR_EN signal from STM32F723IEK6 "STLINK V3" (U5). This pin is connected to a power switch STMPS2151STR (U7), which powers the board. The power switch STMPS2151STR (U7) features also a current limitation to protect the PC in case of short-circuit on board. If an overcurrent (more than 500 mA) happens on board, the red LED LD3 (OC as Over Current) is lit.

The Nucleo board and its shield can be powered from ST-LINK USB connector CN1, but only ST-LINK circuit gets power before USB enumeration, because the host PC only provides 100 mA to the board at that time.

During the USB enumeration, the Nucleo board requires 500 mA power from the host PC.

- If the host is able to provide the required power, the enumeration finishes by a *SetConfiguration* command. Then, the power switch STMPS2151STR is switched ON, the green LED LD4 (5V_PWR) is turned ON, thus Nucleo board and its shield on it can consume 500 mA at the maximum.
- If the host is not able to provide the requested current, the enumeration fails. Therefore, the STMPS2151STR power switch (U7) remains OFF and the MCU part including the extension board is not powered. Therefore, the green LED LD4 remains turned OFF. In this case, it is mandatory to use an external power supply.

Caution: If the maximum current consumption of the STM32G4 Nucleo-32 board and its shield boards exceeds 300 mA, it is either mandatory to check the root cause of the overconsumption, and consequently (if needed) to power the STM32G4 Nucleo-32 board with an external power supply connected to VIN, 5V or 3V3.

2) External power supply input from USB charger (5 V)

In case a USB charger powers the board, there is no USB enumeration. The target is powered anyway.

3) External power supply input from VIN (7 V - 12 V, 800 mA max)

The STM32G4 Nucleo-32 board and its shield boards can be powered in three different ways from an external power supply, depending on the voltage used. The three cases are summarized in [Table 5](#).

Table 5. External power sources: VIN (7 V - 12 V)

Input power name	Connector pins	Voltage range	Maximum current	Limitation
VIN	CN3 pin 1	7 V to 12 V	800 mA	From 7 V to 12 V only and input current capability is linked to input voltage: <ul style="list-style-type: none"> • 800 mA input current when VIN = 7 V • 450 mA input current when 7 V < VIN < 9 V • 250 mA input current when 9 V < VIN < 12 V

4) External power supply input from external 3.3 V

When a shield board provides the 3.3 V, it is interesting to use the 3V3 (CN3 pin 14) directly as power input (refer to [Table 4](#)). In this case, the programming and debugging features are not available, since the ST-LINK is not powered.

Table 6. External power sources: 3V3

Input power name	Connector pins	Voltage range	Maximum current
3V3	CN3 pin 14	3 V to 3.6 V	1.3 A

5) External power supply input from external 5 V

When a shield board provides the 5 V, it is interesting to use the 5V (CN3 pin 4) directly as power input (refer to [Table 7](#)). In this case, the programming and debugging features are not available, since the ST-LINK is not powered.

Table 7. External power sources: 5V

Input power name	Connector pins	Voltage range	Maximum current
5V	CN3 pin 4	4.75 V to 5.25 V	500 mA

6.4.1 Debugging while using VIN or EXT as an external power supply

When powered by VIN or 5V, it is still possible to use the ST-LINK for programming or debugging only, but it is mandatory to power the board first using VIN or EXT (either 3V3 or 5V), then to connect the USB cable to the PC. By acting this way, the enumeration succeeds, thanks to the external power source.

The user must respect the following power-sequence procedure:

1. Connect the external power source to VIN or 5V
2. Power on the external power supply $7\text{ V} < \text{VIN} < 12\text{ V}$ for VIN, or 5 V for 5V
3. Check that the green LED LD4 (5V_PWR) is turned ON
4. Connect the PC to the USB connector CN1

If this order is not respected, the board may be powered by USB first, then by VIN or 5V as the following risks may occur:

1. If the board needs more than 300 mA current, the PC may be damaged or can limit the current supplied. Consequently, the board is not powered correctly.
2. Enumeration requests 300 mA, so there is risk that the request is rejected and the enumeration does not succeed if the PC cannot provide such current. Consequently, the board is not power supplied (LED LD3 remains OFF).

3V3 power supply

Using the 3V3 (CN3 pin 14) directly as power input, can be interesting, for instance, in case a shield provides the 3.3 V. In this case the STLINK-V3E is not powered, thus programming and debugging features are not available.

5V power supply

Using the 5V (CN3 pin 4) directly as power input, can be interesting, for instance, in case a shield provides the 5 V. In this case the STLINK-V3E is not powered, thus programming and debugging features are not available.

External power supply output

When powered by USB or VIN, the 5V (CN3 pin 4) can be used as output power supply for an ARDUINO® Nano shield. In this case, the user must respect the maximum current of the power source specified in "External power sources" table.

The 3V3 (CN3 pin 14) can be used also as power supply output. The maximum current capability of the LD39050PU33R regulator U9 (500 mA max) limits the available current.

6.5 Clock sources

There are four ways to configure the high-speed clock to use.

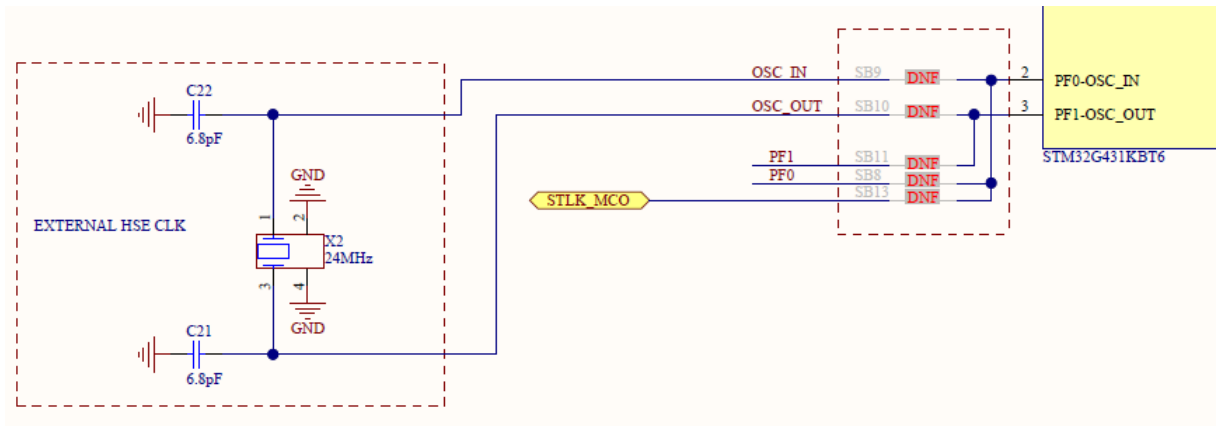
Figure 9. STM32G431KB Nucleo-32 board clock configuration

- **HSI configuration (default):** In that case, no external clock is used. The clock is coming from the STLM32G4 microcontroller. The configuration is:
 - SB9 and SB10 OFF
 - SB11 and SB8 OFF
 - SB13 OFF
- **HSE bypass configuration (from ST-LINK):** The input clock is the ST-LINK MCO output. The frequency is fixed to 25 MHz, and connected to the PF0-OSC_IN of the STM32G4 microcontroller. The configuration must be:
 - SB9 and SB10 OFF
 - SB11 and SB8 OFF
 - **SB13 ON**
- **HSE bypass configuration (from ARDUINO® D7):** The clock is coming from an external oscillator through the pin PF0 (ARDUINO® D7 pin 10 of the CN4 connector). The configuration must be:
 - SB9 and SB10 OFF
 - SB11 OFF and **SB8 ON**
 - SB13 OFF
- **HSE oscillator configuration:** The clock is provided by an external crystal (X2) available in the PCB. The X2 crystal has the following characteristics: 24 MHz, 6 pF load capacitance, 20 ppm. The recommendation is to use NX2016SA-24MHz-EXS00A-CS10820 manufactured by NDK. For typical frequencies and its capacitors and resistors, refer to the STM32 microcontroller datasheet and to the *Oscillator design guide for STM8S, STM8A and STM32 microcontrollers* Application note (AN2867) for the oscillator design guide. The configuration must be:
 - **SB9 and SB10 ON**
 - SB11 and SB8 OFF
 - SB13 OFF

6.6 Board functions

6.6.1 LEDs

LD1 STLINK-V3 COM LED

The bicolor LED LD1 (green, red) provides information about STLINK-V3E communication status. LD1 default color is red. LD1 turns to green to indicate that communication is in progress between the PC and the STLINK-V3E, with the following setup:

- Blinking red: the first USB enumeration with the PC is taking place
- Red LED ON: when the initialization between the PC and STLINK-V3E is complete
- Blinking red or green: during programming and debugging with target
- Orange ON: communication failure

LD2 USER

This green LED is connected to the following STM32G4 I/O:

- PB8, if the configuration is SB7 ON, and SB6 OFF (default configuration)
- PB3, if the configuration is SB7 OFF, and SB6 ON

It is also connected to the ARDUINO® D13 signal.

To light this LED, a high-logic state “1” must be written in the corresponding GPIO PB8 or PB3. A transistor drives the LED, so its consumption does not affect the VDD STM32G4 power measurement.

LD4 5V_PWR

The green LED indicates that the STM32G4 part is powered, and the 5 V power is available on CN3 pin 4.

LD3 USB power fault (OC, overcurrent)

LD3 indicates that the board power consumption on USB ST-LINK exceeds 500 mA. Therefore, the user must check the root cause of the overconsumption, and consequently (if needed) power the STM32G4 Nucleo-32 board with an external power supply.

6.6.2 Push button

B1 RESET (button)

This push button is connected to NRST (PG10-NRST) and is used to reset the STM32G4 microcontroller.

6.6.3 Current consumption measurement (IDD)

Jumper JP1, labeled IDD, is used to measure the STM32G4 microcontroller consumption by removing the jumper and by connecting an ammeter.

- JP1 ON: STM32G4 is powered by 3V3 voltage (default)
- JP1 OFF: an ammeter must be connected to measure the STM32G4 current. If there is no ammeter, the STM32G4 is not powered.

6.6.4 Virtual COM port (VCP): USART

The STM32G4 Nucleo-32 board offers the possibility to connect a USART interface to the STLINK-V3E.

Table 8. USART2 connection

Solder bridge configuration ⁽¹⁾	Feature ⁽¹⁾
SB1, SB12: ON	USART2 (PA2/PA3) connected to STLINK-V3E Virtual COM port.

1. The default configuration is in bold

The communication between the target and the MCU is enabled on USART2 to support the Virtual COM port.

6.7 Solder bridges

All the 16 solder bridges are located on the bottom layer of the STM32G4 Nucleo-32 board.

Table 9. Solder bridge configuration

Solder bridge control	Solder bridge (SB)	State ⁽¹⁾	Description ⁽¹⁾
T_VCP_TX	SB1	ON	T_VCP_TX is connected to STM32G4 I/O PA2.
		OFF	T_VCP_TX is not connected to STM32G4 I/O PA2.
T_VCP_RX	SB12	ON	T_VCP_RX is connected to STM32G4 I/O PA3.
		OFF	T_VCP_RX is not connected to STM32G4 I/O PA3.
3.3 LDO output	SB15	ON	U9 LDO output provides 3.3V.
		OFF	U9 LDO does NOT provide 3.3V. The user must connect an external 3.3V source.
SMD ferrite bead L1	SB5	ON	SMD ferrite bead L1 shunted. VDDA connected on VDD voltage supply
		OFF	SMD ferrite bead L1 on STM32G4 VDDA voltage supply
LD2	SB7	ON	The green user LED LD2 is connected to STM32G4 I/O PB8 (SB7 ON, and SB6 OFF).
		OFF	The green user LED LD2 is connected to STM32G4 I/O PB3 (SB7 OFF, and SB6 ON).
	SB6	ON	The green user LED LD2 is connected to STM32G4 I/O PB3 (SB6 ON, and SB7 OFF).
		OFF	The green user LED LD2 is connected to STM32G4 I/O PB8 (SB6 OFF, and SB7 ON).
AGND	SB16	ON	AGND connected to GND. Reserved, do not modify.
		OFF	AGND not connected to GND.
	SB3	ON	STM32 PA15 is connected to CN3 pin 7 for I2C SCL support on ARDUINO® Nano A5. In such a case, STM32 PA15 does not support ARDUINO® Nano D5 and PA6 must be configured as floating input.
		OFF	CN3 pin 7 is used as ARDUINO® Nano analog input A5 without I2C support and CN4 pin 8 is available as ARDUINO® Nano D5.
	SB2	ON	STM32 PB7 is connected to CN3 pin 8 for I2C SDA support on ARDUINO® Nano A4. In such a case, STM32 PB7 does not support ARDUINO® Nano D4 and PA5 must be configured as floating input.
		OFF	CN3 pin 8 is used as ARDUINO® Nano analog input A4 without I2C support and CN4 pin 7 is available as ARDUINO® Nano D4.
ARD_A2	SB14	ON	ARDUINO® Nano A2 (CN3, pin 10) is connected to STM32G4 I/O PA3.
		OFF	ARDUINO® Nano A2 (CN3, pin 10) is disconnected to STM32G4 I/O PA3.
T_SWO on PB3	SB4	ON	T_SWO connected to PB3.
		OFF	T_SWO not connected to PB3.

Solder bridge control	Solder bridge (SB)	State ⁽¹⁾	Description ⁽¹⁾
HSE CLK selection	SB9 and SB10	ON	HSE provided by external 24 MHz XTAL CLK X2
		OFF	HSE not provided by external 24 MHz XTAL CLK X2
	SB11	ON	PF1-OSC_OUT pin connected to PF1 (ARDUINO® Nano, CN4, pin 11)
		OFF	PF1-OSC_OUT pin not connected to PF1 (ARDUINO® Nano, CN4, pin 11)
	SB8	ON	PF0-OSC_IN pin connected to PF0 (ARDUINO® Nano, CN4, pin 10)
		OFF	PF0-OSC_IN pin not connected to PF0 (ARDUINO® Nano, CN4, pin 10)
	SB13	ON	PF0-OSC_IN provided by 25 MHz ST-LINK MCO
		OFF	PF0-OSC_IN not provided by 25 MHz ST-LINK MCO

1. The default SB state is in bold.

7 Board connectors

Several connectors are present on the STM32G4 Nucleo-32 board.

7.1 STLINK-V3E USB Micro-B connector CN1

The USB socket CN1 connects the embedded STLINK-V3E to the PC for the programming and debugging purposes.

Figure 10. USB Micro-B connector CN1 (front view)

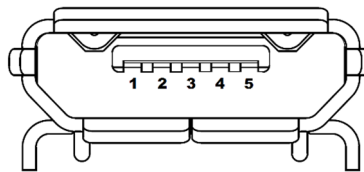

Table 10. USB Micro-B connector CN1 pinout

Connector	Pin number	Pin name	Signal name	STLINK-V3E MCU pin	Function
CN1	1	VBUS	5V_USB_CHGR	-	5 V power
	2	DM	USB_DEV_HS_CN_N	R14	USB diff pair N
	3	DP	USB_DEV_HS_CN_P	R15	USB diff pair P
	4	ID	-	-	-
	5	GND	-	-	GND

7.2 ARDUINO® Nano V3 connectors

The ARDUINO® connectors CN3 and CN4 are male connectors compatible with the ARDUINO® standard. Most shields designed for ARDUINO® can fit with the STM32G4 Nucleo-32 board.

The ARDUINO® connectors on the STM32G4 Nucleo-32 board support the ARDUINO® Nano V3.

Figure 11. ARDUINO® connectors

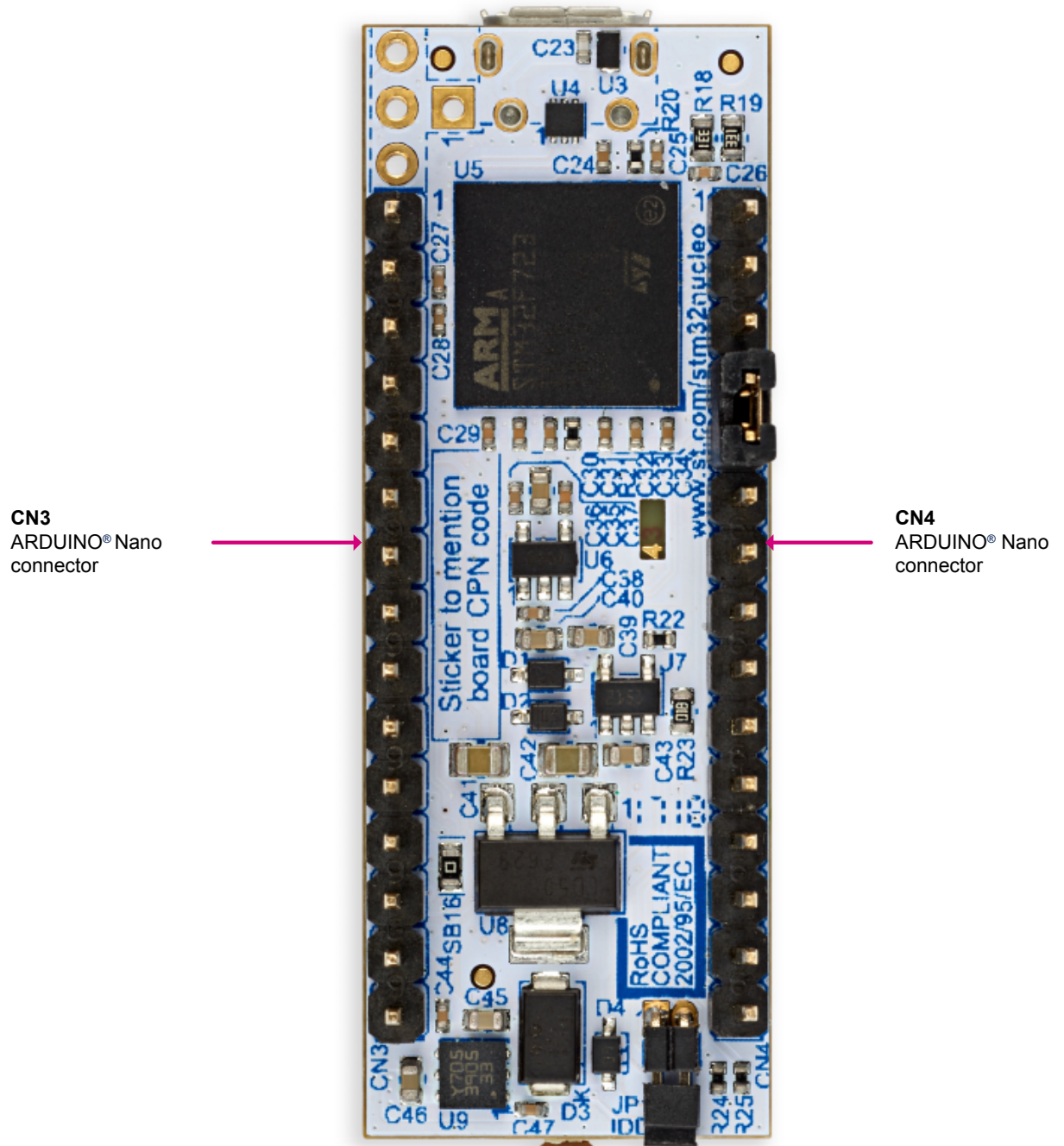

The related pinout for ARDUINO® connector appears in Figure 12 and is listed in Table 11.

Figure 12. ARDUINO® connector pinout

NUCLEO-G431KB					
PA9	1	D1	VIN	1	VIN
PA10	2	D0	GND	2	GND
NRST	3	NRST	NRST	3	NRST
GND	4	GND	+5V	4	+5V
PA12	5	D2	A7	5	PA2
PB0	6	D3	A6	6	PA7
PB7	7	D4	A5	7	PA6/PA15
PA15	8	D5	A4	8	PA5/PB7
PB6	9	D6	A3	9	PA4
PF0	10	D7	A2	10	PA3
PF1	11	D8	A1	11	PA1
PA8	12	D9	A0	12	PA0
PA11	13	D10	AREF	13	AVDD
PB5	14	D11	+3V3	14	+3v3
PB4	15	D12	D13	15	PB3/PB8
	CN4			CN3	



Table 11. ARDUINO® connector pinout

Connector	Pin number	Pin name	Signal name	STLINK-V3E MCU pin	Function
CN3	1	VIN	VIN	-	Power input
	2	GND	GND	-	Ground
	3	T_NRST	T_NRST	PG10_NRST	RESET
	4	5V	5V	-	5V input/output
	5	A7	ARD_A7	PA2	ADC1_IN3
	6	A6	ARD_A6	PA7	ADC2_IN4
	7	A5 ⁽¹⁾	ARD_A5	PA6 PA15	ADC2_IN3 I2C1_SCL
	8	A4 ⁽¹⁾	ARD_A4	PA5 PB7	ADC2_IN13 I2C1_SDA
	9	A3	ARD_A3	PA4	ADC2_IN17
	10	A2	ARD_A2	PA3	ADC1_IN4
	11	A1	ARD_A1	PA1	ADC2_IN2
	12	A0	ARD_A0	PA0	ADC2_IN1
	13	AVDD	AVDD	-	AVDD
	14	3V3	3V3	-	3V3 input/output
	15	D13	ARD_D13	PB3	SPI1_CLK
CN4	1	D1	ARD_D1	PA9	USART1_TX ⁽²⁾
	2	D0	ARD_D0	PA10	USART1_RX ⁽²⁾
	3	T_NRST	T_NRST	PG10_NRST	RESET
	4	GND	-	-	3V3 input/output
	5	D2	ARD_D2	PA12	-
	6	D3	ARD_D3	PB0	PWM: TIM3_CH3
	7	D4 ⁽¹⁾	ARD_D4	PB7	TIM4_CH2 / I2C1_SDA
	8	D5 ⁽¹⁾	ARD_D5	PA15	TIM2_CH1 / I2C1_SCL
	9	D6	ARD_D6	PB6	PWM: TIM1_CH1
	10	D7 ⁽³⁾	ARD_D7	PF0	-
	11	D8 ⁽³⁾	ARD_D8	PF1	-
	12	D9	ARD_D9	PA8	PWM: TIM4_CH1
	13	D10	ARD_D10	PA11	SPI1_CS ⁽⁴⁾ / TIM1_CH4
	14	D11	ARD_D11	PB5	SPI1_MOSI / TIM3_CH2
	15	D12	ARD_D12	PB4	SPI1_MISO

1. Limitations on A4 and A5, related to I²C configuration, are explained in Table 9. Solder bridge configuration according to SB2/SB3 setting.
2. Only one USART is available and shared between ARDUINO® Nano and VCP. The selection is done by remapping (no need to change the hardware configuration).
3. D7/D8 are shared with OSC_IN/OSC_OUT.
4. SPI_CS is handled by GPIO.

8 STM32G4 Nucleo-32 I/O assignment

Table 12. Nucleo-32 I/O assignment

Pin	Pin name	Signal or label	Main feature / optional feature / (SB) ⁽¹⁾
1	VDD	VDD	VDD voltage supply
2	PF0-OSC_IN	PF0-OSC_IN	HSE CLK input / IO
3	PF1-OSC_OUT	PF1-OSC_OUT	HSE CLK output / IO
4	PG10-NRST	T_NRST	RESET
5	PA0	PA0	Analog input - ARD_A0: ADC2_IN1
6	PA1	PA1	Analog input - ARD_A1: ADC2_IN2
7	PA2	T_VCP_TX	USART2_Tx - T_VCP_TX
8	PA3	T_VCP_RX	USART2_Rx - T_VCP_RX / ARD_A2: ADC1_IN4
9	PA4	PA4	Analog input -ARD_A3: DC2_IN17
10	PA5	PA5	Analog input - ARD_A4: DC2_IN13
11	PA6	PA6	Analog input - ARD_A5: DC2_IN3
12	PA7	PA7	Analog input - ARD_A6: DC2_IN4
13	PB0	PB0	ARD_D3 - PWM: TIM3_CH3
14	VSSA	VSSA	Analog Ground
15	VDDA	VDDA	Analog voltage supply
16	VSS	VSS	Ground
17	VDD	VDD	VDD voltage supply
18	PA8	PA8	ARD_D9: PWM: TIM1_CH1
19	PA9	PA9	ARD_D1: USART1_TX
20	PA10	PA10	ARD_D0: USART1_RX
21	PA11	PA11	ARD_D10: SPI1_CS / TIM1_CH4
22	PA12	PA12	ARD_D2: IO
23	PA13	PA13	T_SWDIO
24	PA14	PA14	T_SWCLK
25	PA15	PA15	ARD_D5: TIM2_CH1 / I2C1_SCL
26	PB3	PB3	ARD_D13: SPI1_CLK
27	PB4	PB4	ARD_D12: SPI1_MISO
28	PB5	PB5	ARD_D11: SPI1_MOSI / TIM3_CH2
29	PB6	PB6	ARD_D6: PWM: TIM4_CH1
30	PB7	PB7	ARD_D4: TIM4_CH2 / I2C1_SDA
31	PB8-BOOT0	PB8-BOOT0	BOOT
32	VSS	VSS	Ground

1. The default configuration is in bold.

9 Federal Communications Commission (FCC) and Industry Canada (IC) Compliance Statements

9.1 FCC Compliance Statement

Part 15.19

This device complies with Part 15 of the FCC Rules. Operation is subject to the following two conditions: (1) this device may not cause harmful interference, and (2) this device must accept any interference received, including interference that may cause undesired operation.

Part 15.21

Any changes or modifications to this equipment not expressly approved by STMicroelectronics may cause harmful interference and void the user's authority to operate this equipment.

Part 15.105

This equipment has been tested and found to comply with the limits for a Class B digital device, pursuant to part 15 of the FCC Rules. These limits are designed to provide reasonable protection against harmful interference in a residential installation. This equipment generates uses and can radiate radio frequency energy and, if not installed and used in accordance with the instruction, may cause harmful interference to radio communications. However, there is no guarantee that interference will not occur in a particular installation. If this equipment does cause harmful interference to radio or television reception which can be determined by turning the equipment off and on, the user is encouraged to try to correct interference by one or more of the following measures:

- Reorient or relocate the receiving antenna.
- Increase the separation between the equipment and receiver.
- Connect the equipment into an outlet on circuit different from that to which the receiver is connected.
- Consult the dealer or an experienced radio/TV technician for help.

Note: Use only shielded cables.

Responsible party (in the USA)

Terry Blanchard
Americas Region Legal | Group Vice President and Regional Legal Counsel, The Americas
STMicroelectronics, Inc.
750 Canyon Drive | Suite 300 | Coppel, Texas 75019
USA
Telephone: +1 972-466-7845

9.2 IC Compliance Statement

Industry Canada ICES-003 Compliance Label: CAN ICES-3 (B) / NMB-3 (B).

Revision history

Table 13. Document revision history

Date	Version	Changes
17-May-2019	1	Initial release.
04-Sep-2019	2	Updated: Table 9 and ARDUINO® registered trademark.

Contents

1	Features	2
2	Ordering information	3
2.1	Product marking	3
2.2	Codification	3
3	Development environment	4
3.1	System requirements	4
3.2	Development toolchains	4
3.3	Demonstration software	4
4	Conventions	5
5	Quick start	6
5.1	Getting started	6
6	Hardware layout and configuration	7
6.1	PCB layout.....	7
6.2	Mechanical drawing	9
6.3	Embedded STLINK-V3E	11
6.3.1	Drivers	11
6.3.2	STLINK-V3E firmware upgrade.....	11
6.4	Power supply	11
6.4.1	Debugging while using VIN or EXT as an external power supply	14
6.5	Clock sources	14
6.6	Board functions	16
6.6.1	LEDs.....	16
6.6.2	Push button.....	16
6.6.3	Current consumption measurement (IDD).....	16
6.6.4	Virtual COM port (VCP): USART.....	16
6.7	Solder bridges	16
7	Board connectors	19
7.1	STLINK-V3E USB Micro-B connector CN1	19
7.2	ARDUINO® Nano V3 connectors	19

8	STM32G4 Nucleo-32 I/O assignment	23
9	Federal Communications Commission (FCC) and Industry Canada (IC) Compliance Statements	24
9.1	FCC Compliance Statement	24
9.2	IC Compliance Statement	24
	Revision history	25
	Contents	26
	List of tables	28
	List of figures.....	29

List of tables

Table 1.	Ordering information.	3
Table 2.	Codification explanation	3
Table 3.	ON/OFF convention	5
Table 4.	Jumper configuration	6
Table 5.	External power sources: VIN (7 V - 12 V)	13
Table 6.	External power sources: 3V3	13
Table 7.	External power sources: 5V	14
Table 8.	USART2 connection.	16
Table 9.	Solder bridge configuration	17
Table 10.	USB Micro-B connector CN1 pinout	19
Table 11.	ARDUINO® connector pinout.	22
Table 12.	Nucleo-32 I/O assignment.	23
Table 13.	Document revision history	25

List of figures

Figure 1.	NUCLEO-G431KB top view	1
Figure 2.	NUCLEO-G431KB bottom view	1
Figure 3.	Hardware block diagram	7
Figure 4.	Top layout	8
Figure 5.	Bottom layout	9
Figure 6.	STM32G4 Nucleo 32 board mechanical drawing (in millimeter)	10
Figure 7.	USB composite device	11
Figure 8.	STM32G4 Nucleo-32 board power tree	12
Figure 9.	STM32G431KB Nucleo-32 board clock configuration	15
Figure 10.	USB Micro-B connector CN1 (front view)	19
Figure 11.	ARDUINO® connectors	20
Figure 12.	ARDUINO® connector pinout	21

IMPORTANT NOTICE – PLEASE READ CAREFULLY

STMicroelectronics NV and its subsidiaries (“ST”) reserve the right to make changes, corrections, enhancements, modifications, and improvements to ST products and/or to this document at any time without notice. Purchasers should obtain the latest relevant information on ST products before placing orders. ST products are sold pursuant to ST’s terms and conditions of sale in place at the time of order acknowledgement.

Purchasers are solely responsible for the choice, selection, and use of ST products and ST assumes no liability for application assistance or the design of Purchasers’ products.

No license, express or implied, to any intellectual property right is granted by ST herein.

Resale of ST products with provisions different from the information set forth herein shall void any warranty granted by ST for such product.

ST and the ST logo are trademarks of ST. For additional information about ST trademarks, please refer to www.st.com/trademarks. All other product or service names are the property of their respective owners.

Information in this document supersedes and replaces information previously supplied in any prior versions of this document.

© 2019 STMicroelectronics – All rights reserved