

STM32H5 Nucleo-144 board (MB1404)

Introduction

The STM32H5 Nucleo-144 board based on the MB1404 reference board (order code [NUCLEO-H563ZI](#)) provides an affordable and flexible way for users to try out new concepts and build prototypes, by choosing from the various combinations of performance and power consumption features provided by the STM32H5 series microcontroller.

The ST Zio connector, which extends the ARDUINO® Uno V3 connectivity, and the ST morpho headers provide an easy extension of the functionality of the STM32 Nucleo open development platform with a wide choice of specialized shields.

The STM32H5 Nucleo-144 board does not require any separate probe as it integrates the STLINK-V3EC debugger/ programmer.

The STM32H5 Nucleo-144 board comes with the STM32 comprehensive free software libraries and examples available with the STM32CubeH5 MCU Package.

Figure 1. NUCLEO-H563ZI top view

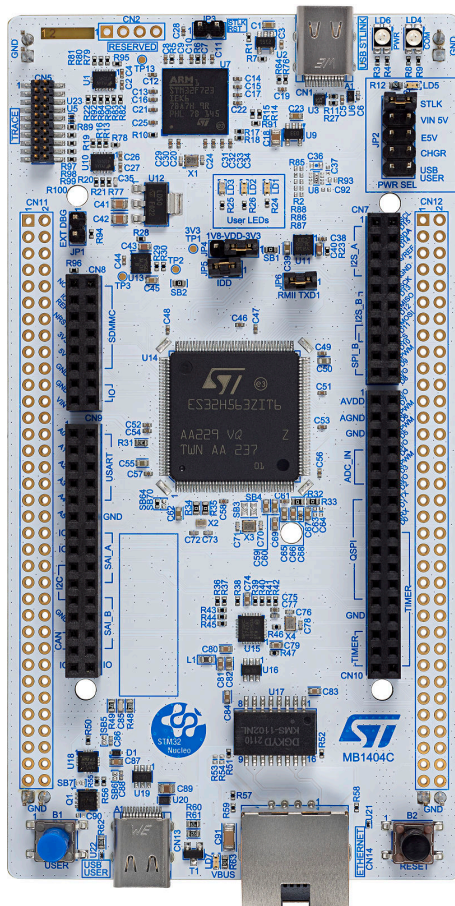
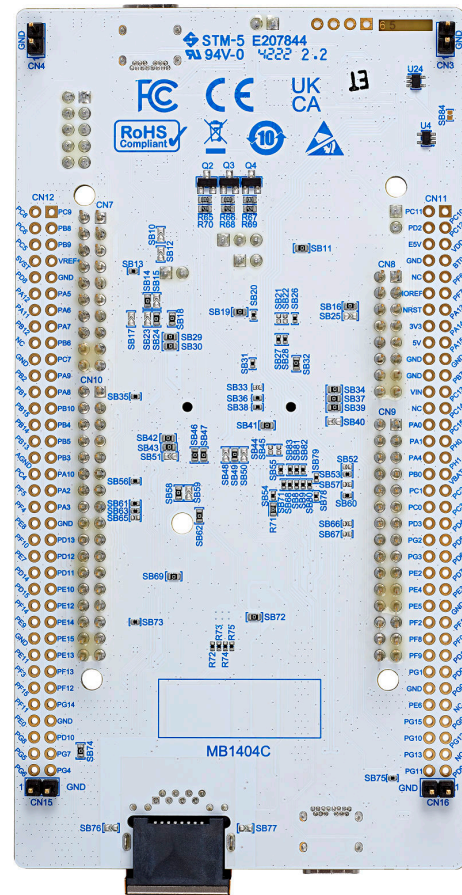

Figure 2. NUCLEO-H563ZI bottom view



Pictures are not contractual.



1 Features

- STM32H563ZIT6 microcontroller based on the Arm® Cortex®-M33 core, featuring 2 Mbytes of flash memory and 640 Kbytes of SRAM in an LQFP144 package
- Ethernet compliant with IEEE-802.3-2002
- USB Type-C® (sink only)
- Three user LEDs
- Reset and user push-buttons
- 32.768 kHz LSE crystal oscillator
- Board connectors:
 - USB Type-C®
 - ST Zio connector including ARDUINO® Uno V3 expansion connector
 - ST morpho extension pin headers for full access to all STM32 I/Os
- Flexible power-supply options: ST-LINK USB V_{BUS} , USB connector, or external sources
- On-board STLINK-V3EC debugger/programmer with USB re-enumeration capability: mass storage, Virtual COM port, and debug port
- Comprehensive free software libraries and examples available with the STM32CubeH5 MCU Package
- Support of a wide choice of Integrated Development Environments (IDEs) including IAR Embedded Workbench®, MDK-ARM, and STM32CubeIDE

Note: Arm is a registered trademark of Arm Limited (or its subsidiaries) in the US and/or elsewhere.



2 Ordering information

To order the STM32H5 Nucleo-144 board, refer to [Table 1](#). Additional information is available from the datasheet and reference manual of the target STM32.

Table 1. Ordering information

Order code	Board reference	Target STM32
NUCLEO-H563ZI	MB1404 ⁽¹⁾	STM32H563ZIT6

1. Subsequently named main board in the rest of the document.

2.1 Products and codification

The meaning of the codification is explained in [Table 2](#).

Table 2. Codification explanation

NUCLEO-XXYYZT	Description	Example: NUCLEO-H563ZI
XX	MCU series in STM32 32-bit Arm Cortex MCUs	STM32H5 series
YY	MCU product line in the series	STM32H563/573
Z	STM32 package pin count	144 pins
T	STM32 flash memory size: • I for 2 Mbytes	2 Mbytes

In this document, for any information that is common to all sales types, the references are noted as the STM32H5 Nucleo-144 board.

3 Development environment

3.1 System requirements

- Multi-OS support: Windows® 10, Linux® 64-bit, or macOS®
- USB Type-A or USB Type-C® to USB Type-C® cable

Note: macOS® is a trademark of Apple Inc., registered in the U.S. and other countries and regions.
Linux® is a registered trademark of Linus Torvalds.
Windows is a trademark of the Microsoft group of companies.

3.2 Development toolchains

- IAR Systems® - IAR Embedded Workbench®⁽¹⁾
- Keil® - MDK-ARM⁽¹⁾
- STMicroelectronics - STM32CubeIDE

1. On Windows® only.

3.3 Demonstration software

The demonstration software, included in the STM32Cube MCU Package corresponding to the on-board microcontroller, is preloaded in the STM32 flash memory for easy demonstration of the device peripherals in standalone mode. The latest versions of the demonstration source code and associated documentation can be downloaded from www.st.com.

4 Conventions

Table 3 provides the conventions used for the ON and OFF settings in the present document.

Table 3. ON/OFF convention

Convention	Definition
Jumper JPx ON	Jumper fitted
Jumper JPx OFF	Jumper not fitted
Jumper JPx [1-2]	Jumper fitted between Pin 1 and Pin 2
Solder bridge SBx ON	SBx connections closed by 0 Ω resistor
Solder bridge SBx OFF	SBx connections left open
Resistor Rx ON	Resistor soldered
Resistor Rx OFF	Resistor not soldered
Capacitor Cx ON	Capacitor soldered
Capacitor Cx OFF	Capacitor not soldered

5 Quick start

The STM32H5 Nucleo-144 board is a low-cost and easy-to-use development kit, to evaluate and start development quickly with an STM32H5 series microcontroller in an LQFP 144-pin package.

Before installing and using the product, accept the Evaluation Product License Agreement from the www.st.com/epla webpage. For more information on the STM32H5 Nucleo-144 board and demonstration software, visit the www.st.com/stm32nucleo webpage.

5.1 Getting started

Follow the sequence below to configure the STM32H5 Nucleo-144 board and launch the demonstration application (refer to [Figure 4](#) and [Figure 5](#) for component location):

1. Check the jumper position on the board as described in [Table 4](#).

Table 4. Default jumper configuration

Jumper	Definition	Position	Comment
JP1	External debug	OFF	-
JP2	Power source selection	[1-2]	STLK (5V_STLK from ST-LINK)
JP3	STLK_RST	OFF	-
JP4	VDD_MCU power selection	[1-2] (default)	VDD_MCU supplied with 3V3_VDD
		[2-3] (optional)	VDD_MCU supplied with 1V8_VDD
JP5	IDD measurement	ON	MCU current measurement
JP6	Ethernet transmit data1	ON	RMIITXD1

2. For the correct identification of the device interfaces from the host PC and before connecting the board, install the Nucleo USB driver available on the www.st.com/stm32nucleo website.
3. Power the board by connecting the STM32H5 Nucleo-144 board to a PC with a USB Type-A or USB Type-C[®] cable through the USB connector (CN1). As a result, the PWR green LED (LD5), the COM LED (LD4), and the PWR LED (LD6) light up, while the three user LEDs (LD1 to LD3) blink.
4. Press the user blue button (B1).
5. Observe how the blinking frequency of the three LEDs (LD1 to LD3) changes, according to the number of clicks on the user button (B1).
6. The software demonstration and the several software examples that allow the user to exercise the Nucleo features, are available at the www.st.com website.
7. Develop your application using the available examples.

6 Hardware layout and configuration

The STM32H5 Nucleo-144 board is designed around an STM32H5 series microcontroller in a 144-pin LQFP package.

Figure 3 shows the connections between the STM32H5 and its peripherals (STLINK-V3EC, push-buttons, LEDs, USB, Ethernet, ST Zio connectors, and ST morpho headers).

Figure 4 and Figure 5 show the location of these features on the STM32H5 Nucleo-144 board.

The mechanical dimensions of the board are shown in Figure 6.

Figure 3. Hardware block diagram

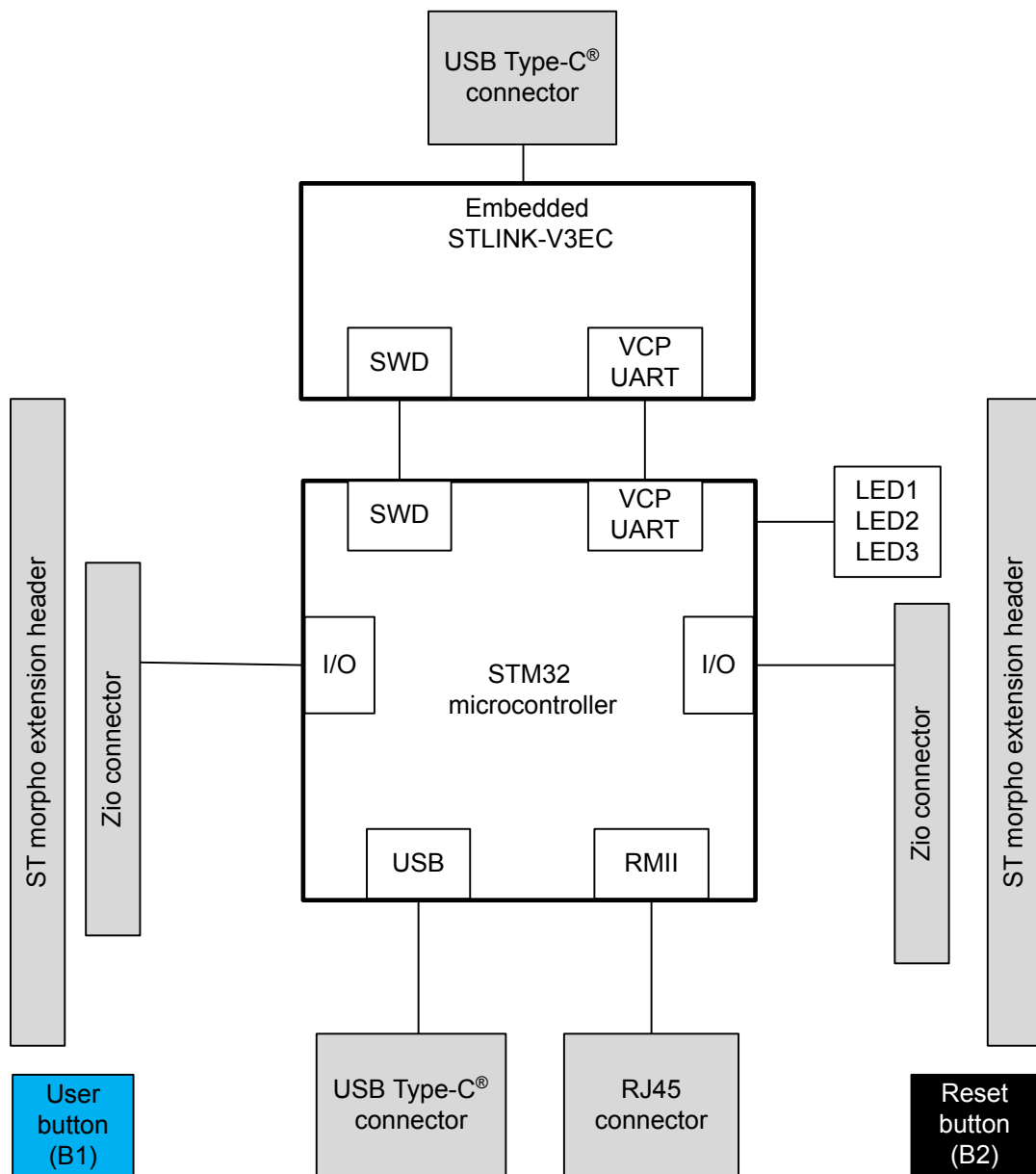

Note: VCP: Virtual COM port
SWD: Serial Wire Debug

DT59060V1

6.1 STM32H5 Nucleo-144 board layout

Figure 4. STM32H5 Nucleo-144 board top layout

Figure 5. STM32H5 Nucleo-144 board bottom layout



6.2 Mechanical drawing

Figure 6. STM32H5 Nucleo-144 board mechanical drawing (in millimeters)

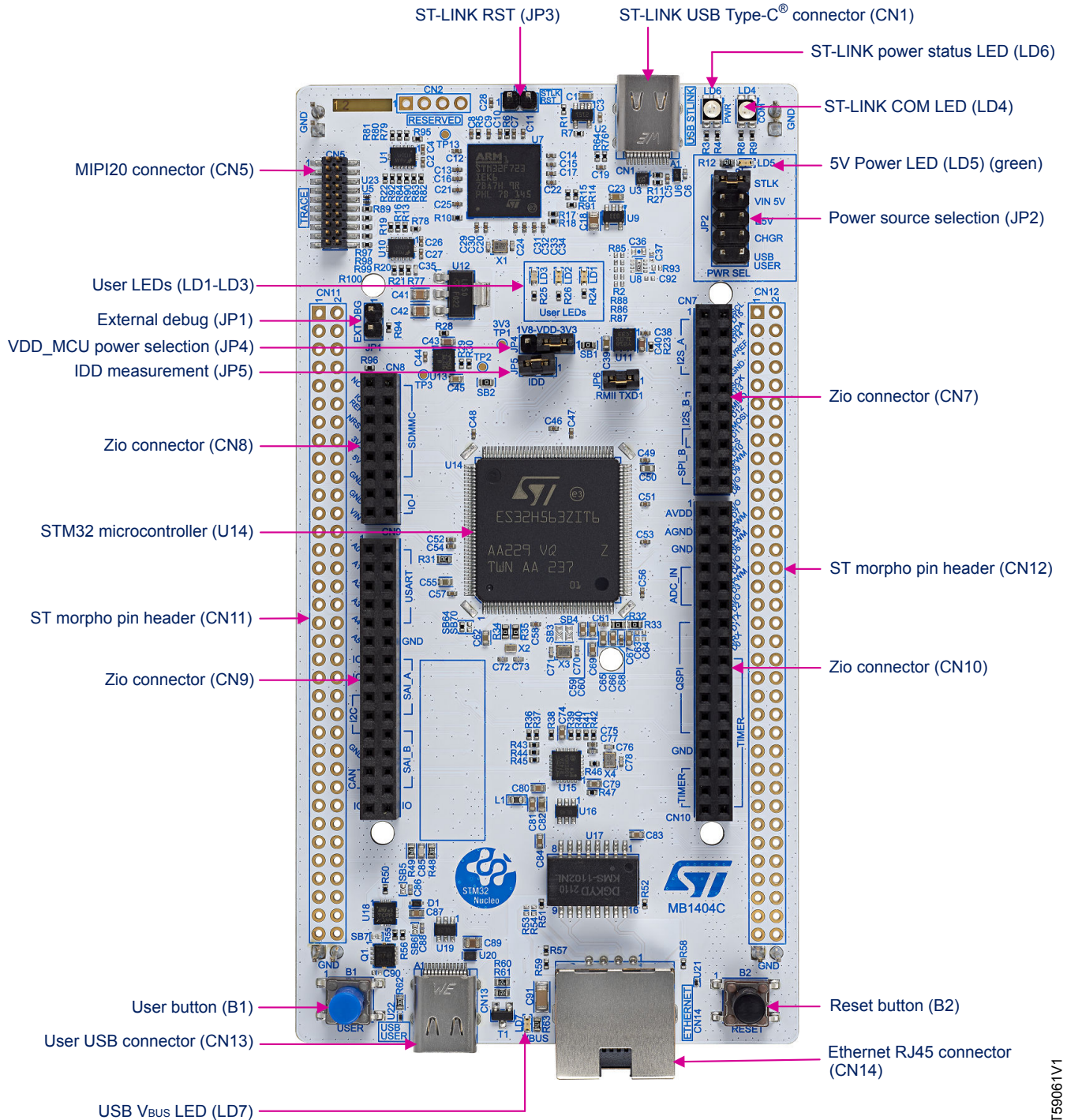
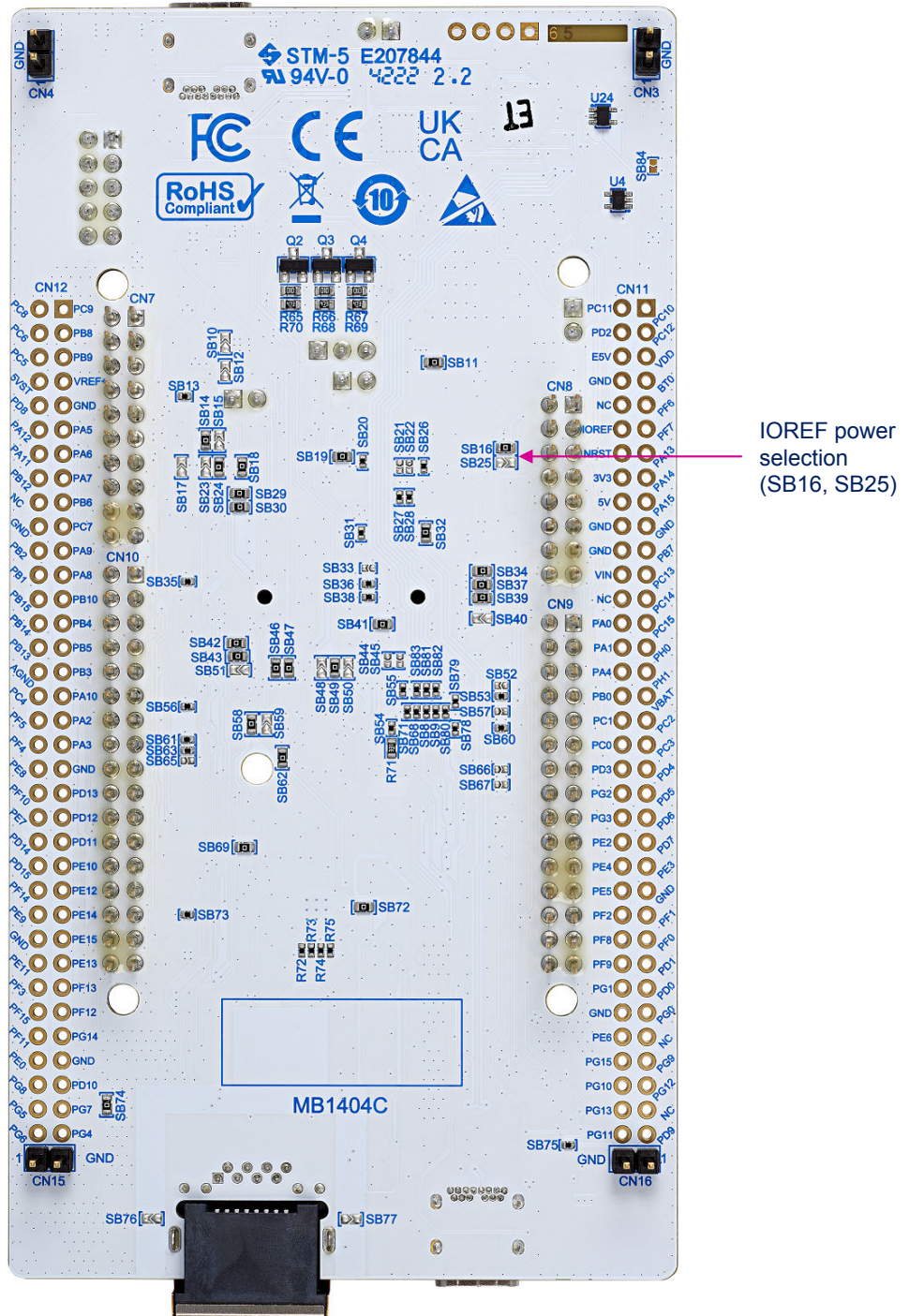
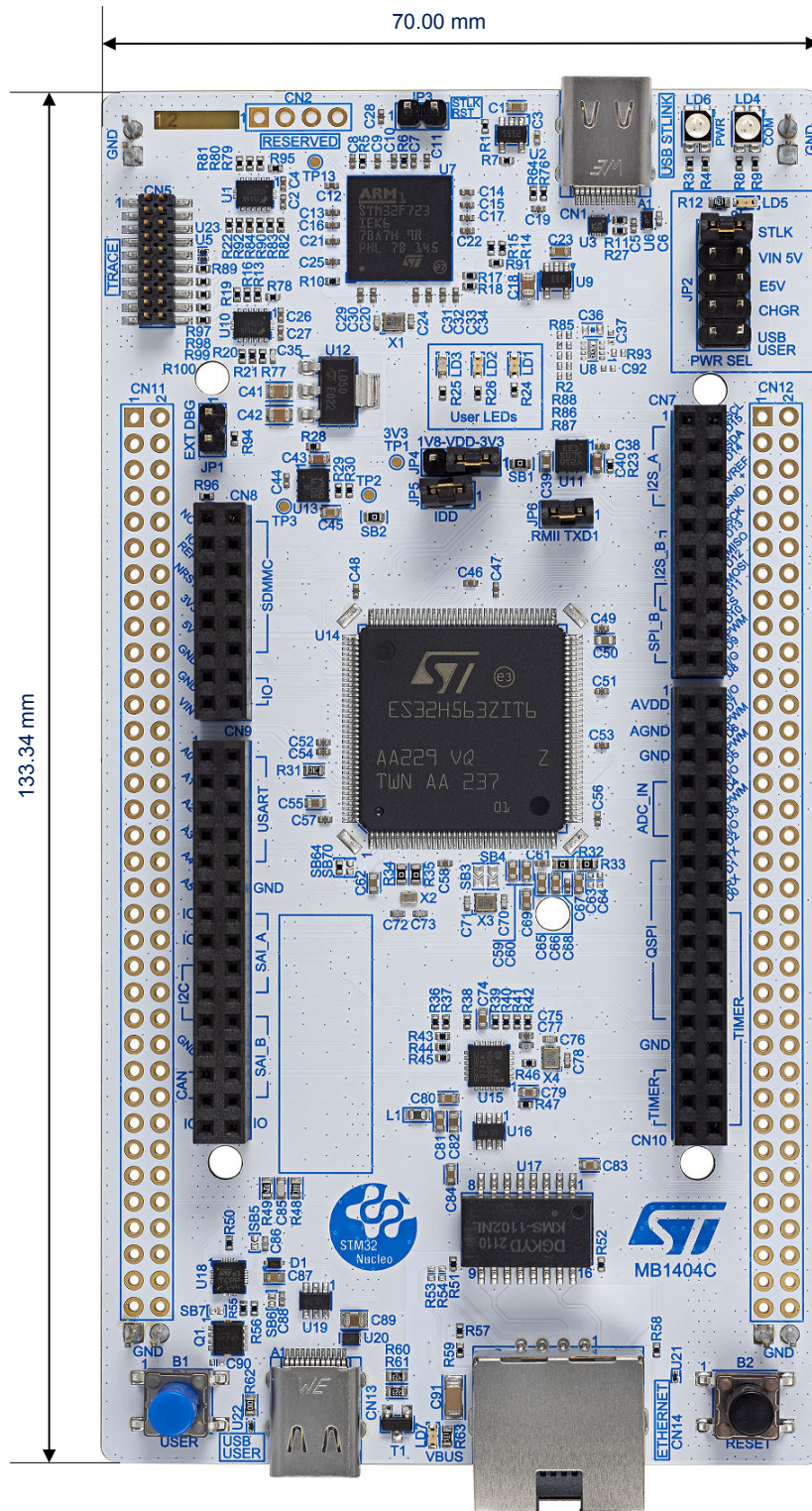

DT59087V1

7 Embedded STLINK-V3EC

The chapter below gives some information about the implementation of STLINK-V3EC.

For more details on STLINK-V3EC such as LEDs management, drivers, and firmware, refer to the technical note *Overview of ST-LINK derivatives (TN1235)*.

For information about the debugging and programming features of STLINK-V3EC, refer to the user manual *STLINK-V3SET debugger/programmer for STM8 and STM32 (UM2448)*.

Description

There are two different ways to program and debug the onboard STM32 MCU.

- Using the embedded STLINK-V3EC programming and debugging tool on the NUCLEO-H563ZI board.
- Using an external debug tool connected to the CN5 MIPI20 connector (SWD/JTAG/TRACE)

The STLINK-V3EC facility for debugging and flashing is integrated into the STM32H5 Nucleo-144 board.

Supported features in STLINK-V3EC:

- 5 V/500 mA power supply capability through the USB Type-C® connector (CN1)
- USB 2.0 high-speed-compatible interface
- JTAG and Serial Wire Debug (SWD) with Serial Wire Viewer (SWV)
- Virtual COM port (VCP)
- 1.7 to 3.6 V application voltage
- COM status LED, which blinks during communication with the PC
- Power status LED giving information about STLINK-V3EC target power.
- Overvoltage protection (U2) with current limitation

Two tricolor LEDs (green, orange, and red) provide information about STLINK-V3EC communication status (LD4) and STLINK-V3EC power status (LD6).

For detailed information about the management of these LEDs, refer to the technical note *Overview of ST-LINK derivatives (TN1235)*.

Drivers

The installation of drivers is not mandatory from Windows 10® but allocates an ST-specific name to the ST-LINK COM port in the system device manager.

For detailed information on the ST-LINK USB drivers, refer to the technical note *Overview of ST-LINK derivatives (TN1235)*.

STLINK-V3EC firmware upgrade

STLINK-V3EC embeds a firmware upgrade (`stsw-link007`) mechanism through the USB-C® port. As the firmware might evolve during the lifetime of the STLINK-V3EC product (for example to add new functionalities, fix bugs, and support new microcontroller families), it is recommended to keep the STLINK-V3EC firmware up to date before starting to use the NUCLEO-H563ZI board. The latest version of this firmware is available from the www.st.com website.

For detailed information about firmware upgrades, refer to the technical note *Overview of ST-LINK derivatives (TN1235)*.

Using an external debug tool to program and debug the on-board STM32

Before connecting any external debug tool to the MIPI20 debug connector (CN5), the SWD and VCP signals from STLINK-V3EC must be isolated. For this, fit the jumper on JP1. It disables the U1 level shifter and isolates SWD and VCP signals from STLINK-V3EC. The configuration of the JP1 is explained in [Table 5](#).

Once the jumper is fitted on JP1, an external debug tool can be connected to the MIPI20 debug connector (CN5).

The two level shifters U1 and U10 allow compatibility between the target MCU signals (1V8 or 3V3) and the STLINK-V3EC signals (3V3). They are used on VCP and SWD interfaces to offer a debug capability when operating the target MCU at 1V8.

Table 5. JP1 configuration

Jumper	Definition	Setting	Comment
JP1	Debugger selection	ON [1-2]	An external debugger connected to the MIPI20 connector (CN5) can be used. The level shifter (U1) is in high impedance (high-Z). STLINK-V3EC no longer drives the embedded STM32
		OFF	The embedded STLINK-V3EC is selected (default configuration).

Note: The MIPI20 TRACE connector supports 1V8 or 3V3 for target reference voltage. When using the external debug connector (CN5), STLINK-V3EC can be used to supply the board through the CN1 USB Type-C® connector. Otherwise, another power supply source can be used as described in Section 8 Power supply.

Figure 7. Connecting an external debug tool to program the on-board STM32

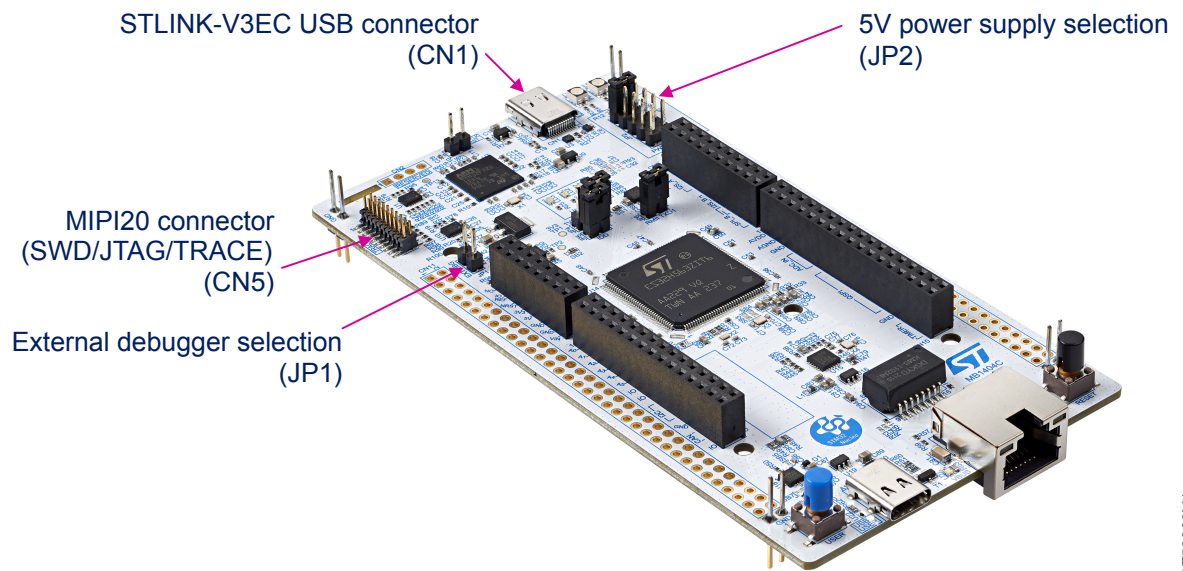

DT59063V1

Table 6. MIPI20 debug connector (CN5) pinout

MIPI20 pin	CN5	Designation
1	VTref	Target reference voltage (fed from VDD)
2	SWDIO/JTMS	Target SWDIO using SWD protocol or target JTMS using JTAG protocol
3	GND	Ground
4	SWCLK/JCLK	Target SWCLK using SWD protocol or target JCLK using JTAG protocol
5	GND	Ground
6	JTDO/SWO	Target SWO using SWD protocol or target JTDO using JTAG protocol
7	KEY	Not connected
8	JTDI	Not used by SWD protocol, target JTDI (T_JTDI) using JTAG protocol, only for external tools
9	GND	Ground
10	NRST	Target NRST using SWD protocol or target JTMS (T_JTMS) using JTAG protocol

MIPI20 pin	CN5	Designation
11	TgtPwr	5 V target power to the target MCU– To be disconnected (SB84 OFF)
12	TRACECLK	Trace clock
13	TgtPwr	5 V target power to the target MCU– To be disconnected (SB84 OFF)
14	TRACED0	Trace Data0
15	GND	Ground
16	TRACED1	Trace Data1
17	GND	Ground
18	TRACED2	Trace Data2
19	GND	Ground
20	TRACED3	Trace Data3

8 Power supply

Six different sources can provide the power supply to NUCLEO-H563ZI:

- A host PC connected to CN1 through a USB cable (default configuration)
- An external 7 to 12 V power supply connected to CN8 pin 15 or CN11 pin 24 (VIN)
- An external 5 V power supply connected to CN11 pin 6 (5V_EXT)
- An external 5 V USB charger (VBUS_STLK) connected to CN1
- A host PC connected to CN13 through a USB cable
- An external 3.3 V power supply (3V3) connected to CN8 pin 7 or CN11 pin 16

In case VIN, 5V_EXT, or 3V3 is used to power the STM32H5 Nucleo-144 board, this power source must comply with the EN-60950-1: 2006+A11/2009 standard and must be safety extra low voltage (SELV) with limited power capability.

In case the power supply is +3.3 V, STLINK-V3EC is not powered and cannot be used.

8.1 Power supply input from STLINK-V3EC USB connector: 5V_STLK (default configuration)

The 5 V signal on the STLINK-V3EC USB connector (CN1) can power the STM32H5 Nucleo-144 board and its shield. To select the 5V_STLK power source, JP2 must be set on [1-2] 'STLK' (refer to Figure 8).

This is the default configuration.

Figure 8. Power supply input from STLINK-V3EC USB connector with PC (5 V, 500 mA maximum)

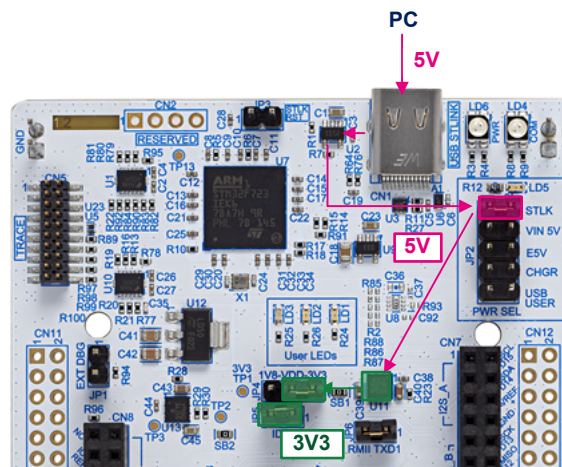

DT59064V1

If the USB enumeration succeeds, the ST-LINK power is enabled, by asserting the T_PWR_EN signal from STLINK-V3EC. This pin is connected to a power switch (U2), which powers the board. The power switch also features a current limitation to protect the PC in case of a short circuit onboard. If an overcurrent (more than 500 mA) happens onboard, the POWER LED STATUS (LD6) is lit in red color.

The STLINK-V3EC USB connector (CN1) can power the Nucleo board with its shield.

- If the host can provide the required power, the power switch and the green LED (LD5) are turned ON. Thus, the Nucleo board and its shield can consume up to 500 mA current, but no more.
- If the host is not able to provide the requested current, the enumeration fails.

Therefore, the power switch (U2) remains OFF and the MCU part including the extension board is not powered. As a consequence, the green LED (LD5) remains turned OFF. In this case, it is mandatory to use an external power supply.

Warning: *In case the maximum current consumption of the STM32H5 Nucleo-144 board and its shield boards exceed 500 mA, it is mandatory to power the STM32H5 Nucleo-144 board, using an external power supply connected to 5V_EXT, VIN, or 3V3.*

8.2 External power supply input from VIN (7 to 12 V, 800 mA maximum)

When the STM32H5 Nucleo-144 board is power supplied by VIN (refer to Table 7 and Figure 9, the JP2 jumper must be fitted on [3-4] (VIN 5V).

The STM32H5 Nucleo-144 board and its shield boards can be powered in three different ways from the VIN external power supply, depending on the used voltage. The three power sources are summarized in Table 7.

Table 7. External power sources VIN (7 to 12 V)

Input power name	Connector pins	Voltage	Maximum current	Limitation
VIN	CN8 pin 15 CN11 pin 24	7 to 12 V	800 mA	From 7 to 12 V only and input current capability is linked to input voltage: <ul style="list-style-type: none"> 800 mA input current when VIN = 7 V 450 mA input current when 7 V < VIN < 9 V 250 mA input current when 9 V < VIN < 12 V

Figure 9. Power supply input from VIN (7 to 12 V, 800 mA maximum)

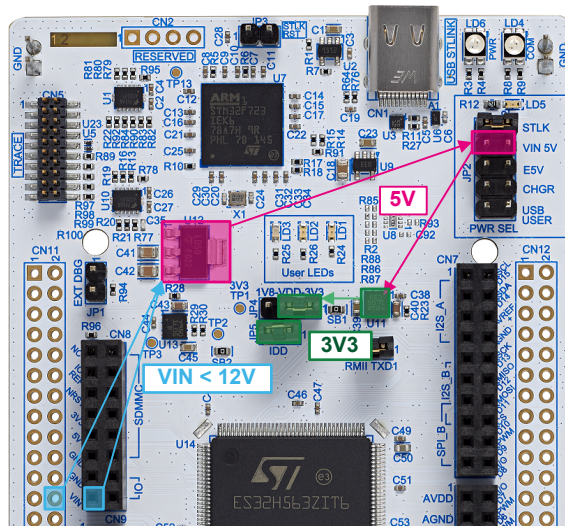

DT59065V1

8.3 External power supply input 5V_EXT (5 V, 1.3 A maximum)

When the STM32H5 Nucleo-144 board is power supplied by 5V_EXT (refer to Figure 10 and Table 8, the JP2 jumper must be fitted on [5-6] (E5V).

Table 8. Power supply input from 5V_EXT (5 V, 1.3 A)

Input power name	Connector pins	Voltage	Maximum current
5V_EXT	CN11 pin 6	4.75 to 5.25 V	1.3 A

Note: Refer to [Using an external debug tool to program and debug the on-board STM32 about debugging when using an external power supply.](#)

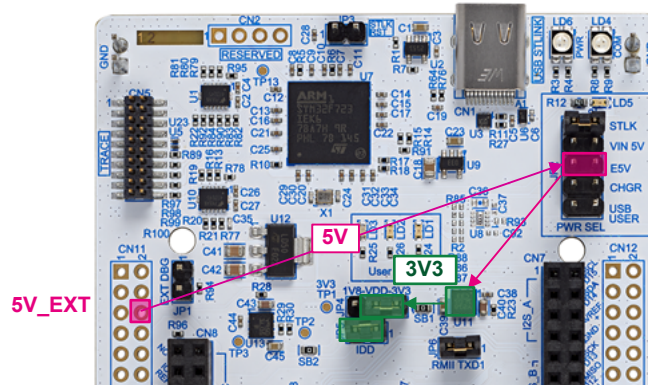
Figure 10. Power supply input from 5V_EXT (5 V, 1.3 A maximum)

DT59066V1

8.4 External power supply input from a USB charger (5 V)

When the STM32H5 Nucleo-144 board is power supplied by a USB charger on CN1 (refer to Figure 11 and Table 9), the JP2 jumper must be set on [7-8] (CHGR).

Table 9. External power source CHGR (5 V)

Input power name	Connector pins	Voltage	Maximum current
CHGR	CN1	5 V	-

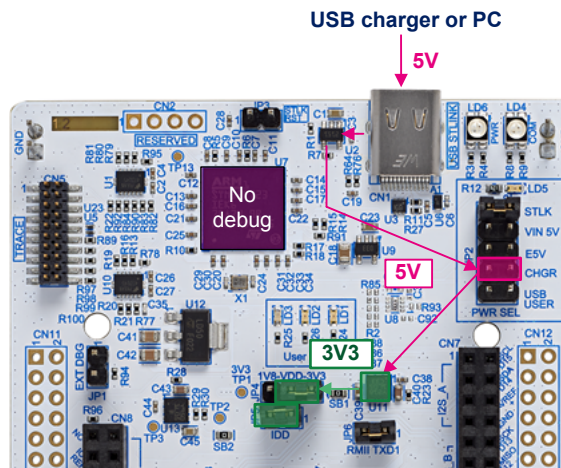
Figure 11. Power supply input from STLINK-V3EC USB connector with a USB charger (5 V)

DT59067V1

8.5 External power supply input from the USB user connector (5 V, 3 A maximum)

The STM32H5 Nucleo-144 board and shield can be powered from the USB user connector (CN13). To select the USB user power source, JP2 must be fitted on [9-10] 'USB USER' (refer to Figure 12 and Table 10).

Table 10. External power source USB user (5 V, 3 A)

Input power name	Connector pins	Voltage	Maximum current
USB USER	CN13	5 V	3 A

Figure 12. Power supply input from USB user connector (5 V, 3 A)

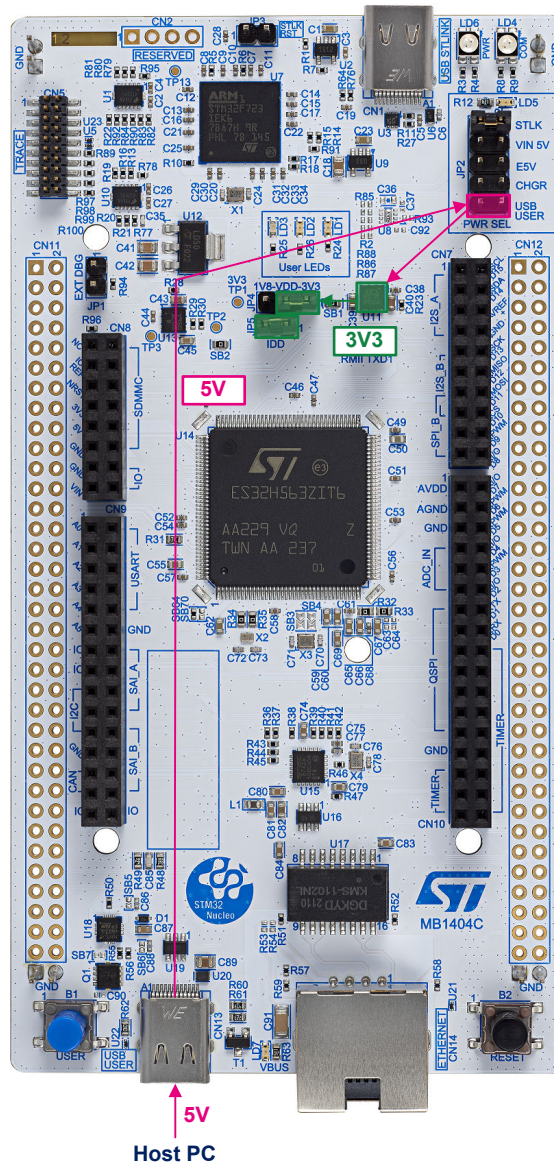

8.6 External power supply input 3V3_EXT (3.3 V, 1.3 A maximum)

In some cases, it might be interesting to use the 3V3 provided by a shield board (CN8 pin 7 or CN11 pin 16) directly as the power input (refer to [Figure 13](#) and [Table 11](#)). In this case, note that programming and debugging features are unavailable as STLINK-V3EC is not powered.

Table 11. External power source 3V3_EXT (3.3 V, 1.3 A maximum)

Input power name	Connector pins	Voltage range	Maximum current
3V3	CN8 pin 7 CN11 pin 16	3.0 to 3.6 V	1.3 A

Figure 13. Power supply input from 3V3_EXT (3.3 V)

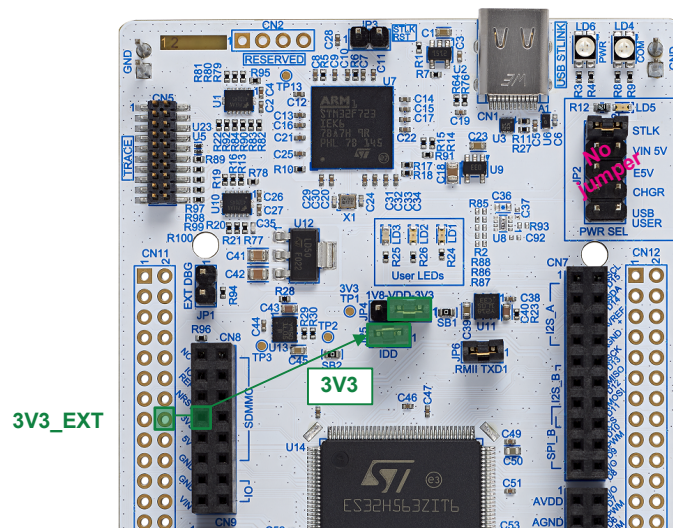

DT59068V1

8.7 Debugging/programming when not using an external power supply

When powered by VIN (VIN 5 V) or 5V_EXT (E5V), it is still possible to use STLINK-V3EC for programming or debugging only. In this case, it is mandatory to power the board first using VIN 5 V or E5V, then connect the USB cable from CN1 to the PC. In this way, the enumeration succeeds, thanks to the external power source.

The following power-sequence procedure must be respected:

1. Configure the jumper JP2 [5-6] for E5V or [3-4] for VIN 5V.
2. Connect the external power source to VIN 5 V or E5V.
3. Power on the external power supply $7\text{ V} < \text{VIN} < 12\text{ V}$ to VIN 5 V, or 5 V for E5V.
4. Check that the green LED (LD5) is turned ON.
5. Connect the PC to the USB connector (CN1).

If this order is not respected, the following risks might be encountered:

1. If the board needs more than 300 mA current, the PC might be damaged, or the PC can limit the supplied current. As a consequence, the board is not powered correctly.
2. If 300 mA is requested during enumeration, there is a risk that the request is rejected and the enumeration does not succeed if the PC cannot provide such current. Consequently, the board is not power supplied. The green LED (LD5) remains OFF.

9 Clock sources

9.1 HSE clock (high-speed external clock)

There are four ways to configure the pins corresponding to the high-speed external clock (HSE):

- MCO from STLINK-V3EC (default): The MCO output of ST-LINK is used as an input clock of the STM32H5. The MCO clock frequency cannot be changed. It is fixed at 8 MHz and connected to the PF0/PH0-OSC_IN of the STM32H5 series microcontroller. The configuration must be:
 - SB49 ON
 - SB48 and SB50 OFF
 - SB3 and SB4 OFF
- HSE on-board oscillator from X3 crystal (provided): For typical frequencies and its capacitors and resistors, refer to the STM32H5 series microcontroller datasheet and the application note *Oscillator design guide for STM8AF/AL/S, STM32 MCUs and MPUs (AN2867)* for the oscillator design guide. The X3 crystal has the following characteristics: 25 MHz, 6 pF, and 20 ppm. ST recommends using NX2016SA-25MHz-EXS00A-CS11321 manufactured by NDK. The configuration must be:
 - SB3 and SB4 ON
 - C69 and C70 ON with 5.6 pF capacitors
 - SB48 and SB50 OFF
 - SB49 OFF
- Oscillator from external PF0/PH0: From an external oscillator through pin 29 of the CN11 connector. The configuration must be:
 - SB50 ON
 - SB48 and SB49 OFF
 - SB3 and SB4 OFF
- HSE not used: PF0/PH0 and PF1/PH1 are used as GPIOs instead of clocks. The configuration must be:
 - SB48 and SB50 ON
 - SB49 OFF
 - SB3 and SB4 OFF

9.2 LSE clock (low-speed external clock): 32.768 kHz

There are three ways to configure the pins corresponding to the low-speed clock (LSE):

- On-board oscillator (default): X2 crystal. Refer to the application note *Oscillator design guide for STM8AF/AL/S, STM32 MCUs and MPUs (AN2867)* for oscillator design guide for STM32H5 series microcontrollers. ST recommends using NX3215SA-32.768kHz-EXS00A-MU00525 (32.768 kHz, 9 pF load capacitance, 20 ppm) from NDK. The configuration must be:
 - SB44 and SB45 OFF
 - R34 and R35 ON
- Oscillator from external PC14: From an external oscillator through pin 25 of the CN11 connector. The configuration must be:
 - SB45 ON
 - SB44 OFF
 - R34 and R35 OFF
- LSE not used: PC14 and PC15 are used as GPIOs instead of the low-speed clock. The configuration must be:
 - SB44 and SB45 ON
 - R34 and R35 OFF

10 Board functions

10.1 LEDs

User green LED (LD1)

The user green LED (LD1) is connected to the PB0 STM32 I/O (SB43 ON and SB51 OFF) or PA5 (SB51 ON and SB43 OFF) corresponding to the D13 ST Zio.

User yellow LED (LD2)

The user yellow LED (LD2) is connected to PF4.

User red LED (LD3)

The user red LED (LD3) is connected to PG4.

These user LEDs are ON when the I/O is in the HIGH state, and are OFF when the I/O is in the LOW state.

COM LED (LD4)

The tri-color (green, orange, and red) LED (LD4) provides information about the ST-LINK communication status. LD4 default color is red. LD4 turns to green to indicate that communication is in progress between the PC and STLINK-V3EC, with the following setup:

- Slow blinking red/OFF at power-on before USB initialization
- Fast blinking red/OFF after the first correct communication between PC and STLINK-V3EC (enumeration)
- Red LED ON when the initialization between the PC and STLINK-V3EC is complete
- Green LED ON after a successful target communication initialization
- Blinking red/green during communication with the target
- Green ON communication finished and successful
- Orange ON communication failure

Green PWR LED (LD5)

The green LED (LD5) indicates that the +5 V power supply is available on the STM32H5 Nucleo-144. This source is available on CN8 pin 9 and CN11 pin 18.

STLINK POWER STATUS LD6

The tricolor LED (LD6) provides information about the STLINK-V3EC target power.

USB Type-C® green LED (LD7)

The green LED (LD7) indicates the V_{BUS} presence on the user USB Type-C® connector (CN13).

10.2 Push-buttons

Blue user button (B1)

The user button is connected to the PC13 I/O by default (tamper support: SB54 ON and SB59 OFF) or PA0 (wake-up support: SB59 ON and SB54 OFF) of the STM32H5 series microcontroller

Black reset button (B2)

This push-button is connected to NRST and is used to reset the STM32H5 series microcontroller.

10.3 MCU voltage selection 1V8/3V3

The STM32H5 Nucleo-144 board offers the possibility to supply the STM32H5 microcontroller with 1.8 or 3.3 V. JP4 is used to select the VDD_MCU power level:

- JP4 jumper must be fitted on [1-2] to supply the MCU with 3V3
- JP4 jumper must be fitted on [2-3] to supply the MCU with 1V8

10.4 Current consumption measurement (IDD)

The JP5 jumper, labeled IDD, is used to measure the STM32H5 microcontroller consumption by removing the jumper and by connecting an ammeter:

- JP5 must be ON when STM32H5 is powered with VDD (default)
- If JP5 is OFF, an ammeter must be connected to measure the STM32H5 current. If there is no ammeter, the STM32H5 is not powered.

10.5 Virtual COM port (VCP): LPUART1/USART3

The STM32H5 Nucleo-144 board offers the flexibility to connect the LPUART1 or the USART3 interface to the STLINK-V3EC, or to the ST morpho and ARDUINO® Uno V3 connectors.

The selection is done by setting the related solder bridges (refer to [Table 12](#) and [Table 13](#) below).

By default, the serial interface USART3 (PD8/PD9) that supports the bootloader is connected and directly available as a Virtual COM port of a PC connected to the STLINK-V3EC USB Type-C® connector (CN1).

Table 12. USART3 connection

Pin name	Definition	Virtual COM port (default configuration)	ST morpho connection
PD8	USART3 TX	SB24 ON SB13, SB15, and SB23 OFF	SB13 ON SB23 and SB24 OFF
PD9	USART3 RX	SB18 ON SB40, SB65, and SB75 OFF	SB75 ON SB18 and SB65 OFF

Table 13. LPUART1 connection

Pin name	Definition	Virtual COM port (default configuration)	ARDUINO® D0 and D1	ST morpho connection
PB6	LPUART1 TX	SB15 and SB23 ON SB14, SB24 OFF	SB14 and SB24 ON SB15 and SB23 OFF	SB14 and SB15 OFF
PB7	LPUART1 RX	SB40 and SB65 ON SB18 and SB63 OFF	SB18 and SB63 ON SB40 and SB65 OFF	SB40 and SB63 OFF

By default:

- Serial communication between the target MCU and ST-LINK MCU is enabled on USART3 because this interface supports the Bootloader mode.
- Serial communication between the target MCU, ARDUINO® Uno V3, and ST morpho connectors is enabled on LPUART1, not to interfere with the VCP interface.

10.6 USB Type-C® FS

The STM32H5 Nucleo-144 board supports USB full-speed (FS) communication. The USB connector (CN13) is a USB Type-C® connector.

The STM32H5 Nucleo-144 board supports the USB Type-C® Sink mode only.

A green LED (LD7) lights up when V_{BUS} is powered by a USB Host and the NUCLEO-H563ZI board works as a USB Device.

10.6.1 USB FS device

When a USB Host connection to the USB Type-C® connector (CN13) of the STM32H5 Nucleo-144 board is detected, the board starts behaving as a USB Device.

Depending on the powering capability of the USB Host, the board can take power from the V_{BUS} terminal of CN13. In the board schematic diagrams, the corresponding power voltage line is called 5V_UCPD. The STM32H5 Nucleo-144 board supports a 5 V USB voltage, from 4.75 to 5.25 V. On the MCU side, VDD_USB supports the 3V3 voltage only. Section 8 provides information on how to use powering options. The hardware configuration for the USB FS interface is shown in Table 14.

Table 14. Hardware configuration for the USB interface

Pin name	Function	Solder bridge	State ⁽¹⁾	Description
PA11	USB_FS_N	SB21	ON	PA11 can be used as a GPIO on the ST morpho connector (CN12). USB function can be used also but performance is degraded due to track length and impedance mismatch.
			OFF	PA11 used as USB_FS_N signal
PA12	USB_FS_P	SB22	ON	PA12 can be used as a GPIO on the ST morpho connector (CN12). USB function can be used also but performance might be degraded due to track length and impedance mismatch.
			OFF	PA12 used as USB_FS_P signal

1. The default configuration is in bold.

10.6.2 UCPD

The USB Type-C® introduces the USB power-delivery feature. The STM32H5 Nucleo-144 supports the dead battery and the Sink mode.

In addition to the DP/DM I/O directly connected to the USB Type-C® connector, five I/Os are also used for UCPD configuration: Configuration channel (UCPD_CC1 and UCPD_CC2), VBUS-SENSE, UCPD dead battery (UCPD_DBn), and UCPD_FLT (FAULT) feature.

To protect the STM32H5 Nucleo-144 from USB overvoltage, a Programmable Power Supply (PPS) compliant USB Type-C® port protection is used: TCPP01-M12 IEC6100-4-2 level 4-compliant IC:

- Configuration Channel I/O: UCPD_CCx: These signals are connected to the associated CCx line of the USB Type-C® connector through the STM USB port protection TCPP01-M12. These lines are used for the configuration channel lines (CCx) to select the USB Type-C® current mode. The STM32H5 Nucleo-144 supports only Sink current mode.
- Dead battery I/O: UCPD_DBn: This signal is connected to the associated DBn line of the TCPP01-M12. The STM USB port protection TCPP01-M12 internally manages the dead battery resistors.
- V_{BUS} fault detection: UCPD_FLT: This signal is provided by the ST USB Type-C® port protection. It is used as a fault reporting to the MCU after a bad V_{BUS} level detection. By design, the STM32H5 Nucleo-144 V_{BUS} protection is set to 6 V maximum. (R56 is set to 2.4 kΩ to select 6 V maximum).

Table 15. Hardware configuration for the UCPD feature

Pin name	Function	Solder Bridge	State ⁽¹⁾	Description
PB13	UCPD_CC1	SB29	ON	PB13 is connected to the USB Type-C® port protection and used as UCPD_CC1. (SB6 and SB12 must be OFF). If SB6 is ON, thus the protection on the CC1 line is bypassed
			OFF	PB13 can be used as: <ul style="list-style-type: none"> • GPIO on ST morpho connector (CN12) <ul style="list-style-type: none"> – (SB12 must be OFF) • I2S_CK signal on the Zio connector (CN7) <ul style="list-style-type: none"> – (SB12 must be ON).
PB14	UCPD_CC2	SB30	ON	PB14 is connected to the USB Type-C® port protection and used as UCPD_CC2. (SB5 must be OFF). If SB5 is ON, the protection on the CC2 line is bypassed
			OFF	PB13 can be used as a GPIO on the ST morpho connector (CN12)
PG7	UCPD_FLT	SB74	ON	PG7 is connected to the USB Type-C® port protection and used as overvoltage fault reporting to the MCU.
			OFF	PB13 can be used as a GPIO on the ST morpho connector (CN12)
PA9	UCPD_DBN	SB31	ON	PA9 is connected to the USB Type-C® port protection and is used as a dead battery feature
			OFF	PA9 can be used as a GPIO on the ST morpho connector (CN12)
PA4	VBUS_SENSE	SB56	ON	PA4 is used as the VBUS_SENSE signal
			OFF	PA4 can be used as a GPIO on the ST morpho connector (CN11)

1. The default configuration is in bold.

10.7 Ethernet

The STM32H5 Nucleo-144 board supports 10M/100M Ethernet communication by a PHY LAN8742A-CZ-TR (U15) and RJ45 connector (CN14). Ethernet PHY is connected to the STM32H5 series microcontroller via the RMII interface. The PHY RMII_REF_CLK generates the 50 MHz clock for the STM32H5 series microcontroller.

Note: Make sure that JP6 is ON when using Ethernet.

Note: Ethernet PHY LAN8742A must be set in power-down mode (in this mode, the Ethernet PHY reference clock turns off) to achieve the expected low-power mode current. This is done by configuring the Ethernet PHY basic control register (at address 0x00) bit 11 (power down) to '1'. SB58 can also be OFF to get the same effect.

Table 16. Ethernet pin configuration

Pin name	Function	Conflict with Zio connector signal	Configuration when using Ethernet	Configuration when using ST Zio or ST morpho connector
PA1	RMII reference clock	-	SB58 ON	SB58 OFF
PA2	RMII MDIO	-	SB69 ON	SB69 OFF
PC1	RMII MDC	-	SB62 ON	SB62 OFF
PA7	RMII RX data valid	-	SB38 ON	SB38 OFF
PC4	RMII RXD0	-	SB42 ON	SB42 OFF
PC5	RMII RXD1	-	SB36 ON	SB36 OFF
PG11	RMII TX enable	-	SB34 ON	SB34 OFF
PG13	RXII TXD0	-	SB37 ON	SB37 OFF
PB15	RMII TXD1	I2S_A_SD	JP6 ON	JP6 OFF

11 Solder bridges and jumpers

SBxx can be found on the top layer and SB1xx can be found on the bottom layer of the STM32H5 Nucleo-144 board.

Table 17. Solder bridge and jumper configuration

Solder Bridge	State ⁽¹⁾	Description
SB1 (3V3)	ON	Output of voltage regulator ST1L05CPU33R is connected to 3V3.
	OFF	Output of voltage regulator ST1L05CPU33R is not connected to 3V3.
SB2 (1V8)	ON	Output of voltage regulator ST1L05BPUR is connected to 1V8.
	OFF	Output of voltage regulator ST1L05BPUR is not connected to 1V8.
SB3, SB4 (External 25 MHz crystal)	ON, ON	PH0/PF0 and PH1/PF1 are connected to the external 25 MHz crystal X3.
	OFF, OFF	PH0/PF0 and PH1/PF1 are not connected to the external 25 MHz crystal X3.
SB5, SB6 (OVP protections on CC lines)	ON, ON	The overvoltage protections on CC1 and CC2 lines are bypassed.
	OFF, OFF	The overvoltage protections on CC1 and CC2 lines are connected.
SB7 (OVP protection on V _{BUS} line)	ON	The overvoltage protection on the V _{BUS} line is bypassed.
	OFF	The overvoltage protection on the V _{BUS} line is connected.
SB8, SB9, SB64, SB68, SB78 (trace signals)	ON, ON, ON, ON, ON	PE2, PE3, PE4, PE5, and PE6 are used as GPIOs on the ST morpho connector (CN11) or on the Zio connector (CN9).
	OFF, OFF, OFF, OFF, OFF	PE2, PE3, PE4, PE5, and PE6 are used as trace signals and are connected to the MIPI-20 connector (CN5). SB70 and SB71 must be OFF.
SB10 (PB15)	ON	PB15 can be used as I2S_2_SD or a GPIO signal on the Zio connector (pin 3 of CN7) if not used on the ST morpho.
	OFF	PB15 is used as RMII_TXD1 signal.
SB11	ON	The input of the ST1L05BPUR LDO is connected to 3V3.
	OFF	The input of the ST1L05BPUR LDO is not connected to 3V3.
SB12 (PB13)	ON	PB13 can be used as I2S_2_CK or GPIO signal on the Zio connector (CN7/pin5) if not used on the ST morpho.
	OFF	PB13 is used as the UCPD_CC1 signal.
SB13 (PD8)	ON	PD8 is connected to the ST morpho (CN12/pin12).
	OFF	PD8 is not connected to the ST morpho (CN12/pin12).
SB14, SB63, SB15, SB40 (PB6, PB7)	ON, ON, OFF, OFF	LPUART1 is connected to ARDUINO® D0 and D1 (default).
	OFF, OFF	LPUART1 connected to Virtual COM port (VCP).
	ON, ON	
SB16, SB25	ON, OFF	IOREF is connected to VDD (default).
	OFF, ON	IOREF is connected to 3V3.
SB17 (PB5)	ON	PB5 (SPI1_MOSI/I2S_3_MCK) is connected to the ST Zio connector (pin13 of CN7).
	OFF	PB5 (SPI1_MOSI/I2S_3_MCK) is not connected to the ST Zio connector (pin13 of CN7).

Solder Bridge	State ⁽¹⁾	Description
SB18, SB24, SB23, SB65 (USART3)	ON, ON, OFF, OFF	USART3 is connected to the Virtual COM Port (VCP) (default).
	OFF, OFF, ON, ON	USART3 is connected to ARDUINO® D0 and D1.
SB19 (SDMMC_D0) SB20 (SDMMC_D1)	ON	SDMMC data (D0/D1) signals are connected to the ST morpho connector (CN12).
	OFF	SDMMC data signals (D0/D1) are not connected to the ST morpho connector (CN12) to avoid stubs on SDMMC data signals.
SB21 (PA11) SB22 (PA12)	ON, ON	These pins can be used as GPIOs on the ST morpho connector (CN12). (SB27 and SB28 must be OFF).
	OFF, OFF	These pins are used as D- and D+ on the USB connector (CN13). (SB27 and SB28 must be ON). (Default).
SB26 (VDD33_USB_2)	ON	VDD33_USB_2 pin of STM32H5 is connected to 3V3.
	OFF	VDD33_USB_2 pin of STM32H5 is not connected.
SB29 (PB13) SB30 (PB14)	ON, ON	PB13 and PB14 are used as the UCPD_CC1 and UCPD_CC2 signals. (SB12 must be OFF)
	OFF, OFF	PB13 and PB14 can be used as GPIOs on the ST morpho connector (CN12). (SB12 must be OFF). PB13 can be used as the I2S_2_CK signal on the ST Zio connector (CN7) (SB12 must be ON).
SB31 (PA9)	ON	PA9 is connected and used as the UCPD_DBn signal (dead battery detection).
	OFF	PA9 can be used as GPIO on the ST morpho connector (CN12).
SB32 (VDD_MMC_1)	ON	VDD_MMC_1 pin of STM32H5 is connected to VDD_MCU.
	OFF	VDD_MMC_1 pin of STM32H5 is not connected.
SB33, SB39 (PB3)	OFF, ON	SWO signal of the STM32H5 (PB3) is connected to the ST-LINK SWO input (SB33 must be OFF).
	ON, OFF	PB3 is connected on ST Zio connector (CN7) and can be used as I2S_3_CK/ SPI1_SCK signals.
	OFF, OFF	PB3 can be used as GPIOs on the ST morpho connector (CN12).
RMII signals SB34 (PG11), SB36 (PC5), SB37 (PG13), SB38 (PA7), SB42 (PC4), SB58 (PA1), SB62 (PC1), SB69 (PA2), JP6 (PB15)	ON	These pins are used as RMII signals and connected to Ethernet PHY. SB10 must be OFF. PB15 can be used as I2S_2_SD on ST Zio (pin 3 of CN7) if not used on the ST morpho.
	OFF	These pins can be used as GPIOs on the ST morpho connectors. PB15 can be used as I2S_2_SD on ST Zio (pin 3 of CN7) if not used on the ST morpho.
SB35, SB67 (PE9)	ON, OFF	PE9 is used as TIM1_CH1 on the ST Zio connector (CN9)
	OFF, ON	PE9 is used as GPIO on the ST Zio connector (CN9) and the ST morpho connector (CN12).
SB43, SB51 (LD1 green LED)	ON, OFF	The green user LED (LD1) is connected to PB0. (default).
	OFF, ON	The green user LED (LD1) is connected to D13 of the ARDUINO® signal (PA5).
	OFF, OFF	The green user LED (LD1) is not connected.
SB44, SB45 (32.768 kHz crystal)	ON, ON	PC14 and PC15 are connected to the ST morpho connector (CN11). R34 and R35 must be OFF.

Solder Bridge	State ⁽¹⁾	Description
SB44, SB45 (32.768 kHz crystal)	OFF, OFF	X2 Crystal provides the 32.768KHz clock. PC14 and PC15 are not connected to the ST morpho connector (CN11).
SB48, SB49, SB50 (HSE clock)	OFF, ON, OFF	The MCO clock (8 MHz) from ST-LINK is used as the main clock of the STM32H563ZIT6 MCU and is connected to its PH0-OSCIN pin. (Default). SB3 and SB4 must be OFF.
	ON, OFF, ON	PF0/PH0 and PF1/PH1 are connected to the ST morpho connector (CN11). SB3 and SB4 must be OFF.
	OFF, OFF, OFF	PF0/PH0 and PF1/PH1 are connected to the external 25 MHz crystal X3. SB3 and SB4 must be ON.
SB52, SB57 (I ² C)	ON, ON	The I2C1 bus is connected to the ST Zio connector (pin9 and pin11 of CN9). SB53 and SB60 must be OFF.
	OFF, OFF	The I2C1 bus is not connected to the ST Zio connector (pin9 and pin11 of CN9). ADC_IN are connected to A4 and A5 (pin 9 and pin 11) on the ST Zio connector (CN9). Thus, SB53 and SB60 must be ON.
SB54, SB59 (B1 user button)	ON, OFF	The B1 push-button is connected to PC13.
	OFF, ON	The B1 push-button is connected to PA0 (set SB73 OFF if the ST Zio connector is used).
	OFF, OFF	The B1 push-button is not connected.
SB55 (VBAT)	ON	The VBAT pin of the STM32H5 is connected to VDD_MCU.
	OFF	The VBAT pin of the STM32H5 is not connected to VDD_MCU.
SB56 (VBUS_SENSE)	ON	PA4 is connected to the VBUS_SENSE signal.
	OFF	PA4 is not connected to the VBUS_SENSE signal and can be used as GPIO on the ST morpho connector (CN11).
SB61, SB66 (PB2)	ON, OFF	PB2 is used as QSPI_CK signal on the ST Zio connector (pin15 of CN10).
	OFF, ON	PB2 can be used as GPIO on the ST Zio connector (pin13 of CN9).
	OFF, OFF	PB2 can be used as GPIO on the ST morpho connector (CN12)
SB70 (PE2)	ON	PE2 is connected to the ST Zio connector (pin25 of CN10) and is used as the QSPI_BK1_IO2 signal.
	OFF	PE2 can be used as the trace signal if SB64 is OFF or as the SAI_A_MCLK signal on ST Zio connector (pin14 of CN9) if SB64 is ON.
SB71 (PE6)	ON	PE6 is connected to the ST Zio connector (pin28 of CN10) and is used as the TIMER_1_BKIN1 signal. SB68 must be OFF.
	OFF	PE2 can be used as the trace signal if SB68 is OFF or as the SAI_A_SD signal on ST Zio connector (pin20 of CN9) if SB68 is ON.
SB72 (Ethernet nRST) RMII signal	ON	NRST of STM32H5 is connected to Ethernet PHY (U15).
	OFF	NRST of STM32H5 is not connected to Ethernet PHY (U15).
SB73 (PA0)	ON	PA0 is connected to the ST Zio connector (pin 29 of CN10).
	OFF	PA0 is not connected to the ST Zio connector (pin 29 of CN10).
SB74 (PG7)	ON	PG7 is used as the UCPD_FLT signal.
	OFF	PG7 can be used as GPIO on the ST morpho connector (CN12).
SB75 (PD9)	ON	PD9 is connected to the ST morpho connector (CN11).
	OFF	PD9 is not connected to the ST morpho connector (CN11).
SB84 (TargetPwr)	ON	The pin11 and pin15 (TrgtPwr pins) of trace connector CN5 are connected to GND.
	OFF	The pin11 and pin15 (TrgtPwr pins) of trace connector CN5 are not connected to GND.

Solder Bridge	State ⁽¹⁾	Description
JP1 (external debug)	ON	An external debugger connected to the MIPI20 connector (CN5) can be used. The level shifter (U1) is in high impedance (high-Z). STLINK-V3EC no longer drives the embedded STM32.
	OFF	The embedded STLINK-V3EC is selected (default configuration).
JP3 (ST-LINK RST)	ON	STLINK-V3EC is in the Reset mode.
	OFF	STLINK-V3EC is active.
JP5 (IDD)	ON	VDD_MCU is connected to VDD.
	OFF	VDD_MCU is not connected to VDD (the MCU is not power supplied).

1. The default status is in bold.

All the other solder bridges present on the STM32H5 Nucleo-144 board are used to configure several I/Os and power supply pins for compatibility of features and pinout with the target-supported STM32H5.

The STM32H5 Nucleo-144 board is delivered with the solder bridges configured according to the target STM32H5 supported.

12 Board connectors

Several connectors are implemented on the STM32H5 Nucleo-144 board.

12.1 STLINK-V3EC USB Type-C® connector (CN1)

The USB Type-C® connector (CN1) is used to connect the embedded STLINK-V3EC to the PC for programming and debugging purposes.

Figure 14. USB Type-C® connector (CN1) front view



The related pinout for the USB STLINK-V3EC connector is listed in [Table 18](#).

Table 18. STLINK-V3EC USB Type-C® connector (CN1) pinout

Connector	Pin number	Pin name	Signal name	STM32H5 pin	Function
CN1	A1	GND	GND	-	Ground
	A4	VBUS	VBUS_STLK	-	Power
	A5	CC1	STLK_UCPD_CC1_C	PC3	USB-PD controller side for the CC1 pin
	A6	D+	STLK_USB_P	PB15	USB differential pair P
	A7	D-	STLK_USB_N	PB14	USB differential pair M
	A8	SBU1	-	-	-
	A9	VBUS	VBUS_STLK	-	Power
	A12	GND	GND	-	Ground
	B1	GND	GND	-	Ground
	B4	VBUS	VBUS_STLK	-	Power
	B5	CC2	STLK_UCPD_CC2_C	PC4	USB-PD controller side for the CC2 pin
	B6	D+	STLK_USB_P	PB15	USB differential pair P
	B7	D-	STLK_USB_N	PB14	USB differential pair M
	B9	VBUS	VBUS_STLK	-	Power
B12	GND	GND	-	Ground	

12.2 User USB Type-C® connector (CN13)

Figure 15. USB Type-C® connector (CN13) front view



The related pinout for the user USB connector is listed in Table 19.

Table 19. User USB Type-C® connector (CN13) pinout

Connector	Pin number	Pin name	Signal name	STM32H5 pin	Function
CN13	A1	GND	GND	-	Ground
	A4	VBUS	VBUSc	-	Power
	A5	CC1	UCPD_CC1	PB13	USB-PD controller side for the CC1 pin
	A6	D+	USB_FS_P	PA12	USB differential pair P
	A7	D-	USB_FS_N	PB11	USB differential pair M
	A8	SBU1	-	-	-
	A9	VBUS	VBUSc	-	Power
	A12	GND	GND	-	Ground
	B1	GND	GND	-	Ground
	B4	VBUS	VBUSc	-	Power
	B5	CC2	UCPD_CC2	PB14	USB-PD controller side for the CC2 pin
	B6	D+	USB_FS_P	PA12	USB differential pair P
	B7	D-	USB_FS_N	PA11	USB differential pair M
	B9	VBUS	VBUSc	-	Power
	B12	GND	GND	-	Ground

12.3 Ethernet RJ45 connector (CN14)

The STM32H5 Nucleo-144 board supports 10 Mbps/100 Mbps Ethernet communication with the LAN8742A-CZ-TR PHY (U15) from MICROCHIP and integrated RJ45 connector (CN14). The Ethernet PHY is connected to the MCU via the RMII interface.

The X4 oscillator generates the 25 MHz clock for the PHY. The 50 MHz clock for the MCU (derived from the 25 MHz crystal oscillator) is provided by the RMII_REF_CLK of the PHY.

Figure 16. Ethernet RJ45 connector (CN14) front view

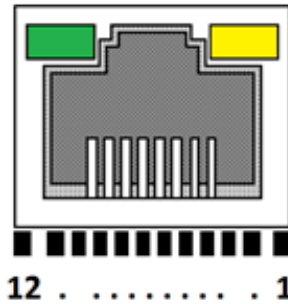

1. Green LED: Ethernet traffic
2. Amber LED: Ethernet connection

The related pinout for the Ethernet connector is listed in [Table 20. Ethernet connector \(CN14\) pinout](#).

Table 20. Ethernet connector (CN14) pinout

Connector	Pin number	Description	MCU pin	Pin number	Description	MCU pin
CN14	1	TX+	-	7	NC	-
	2	TX-	-	8	NC	-
	3	RX+	-	9	Yellow LED cathode	-
	4	NC	-	10	Yellow LED anode	-
	5	NC	-	11	Green LED cathode	-
	6	RX-	-	12	Green LED anode	-

13 Expansion connectors

13.1 ST Zio connectors

For all STM32H5 Nucleo-144 boards, Figure 17 shows the signals connected by default to the ST Zio connectors (CN7, CN8, CN9, and CN10), including the support of ARDUINO® Uno V3.

Figure 17. STM32H5 Nucleo-144 board

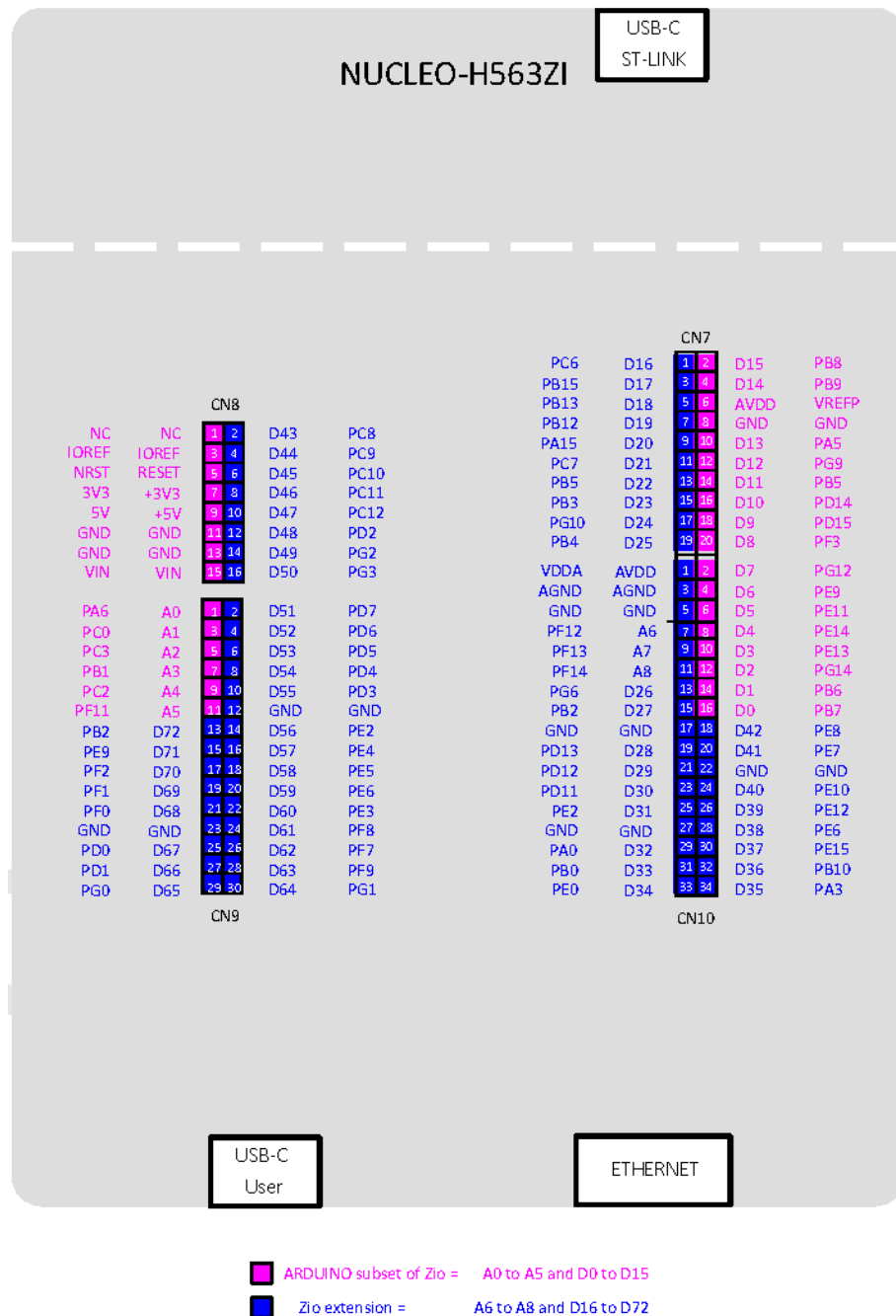

To cope with ARDUINO® Uno V3, apply the following modifications:

- SB52 and SB57 must be ON
- SB53 and SB60 must be OFF to connect I²C on A4 (pin 9) and A5 (pin 11 of CN9).

Caution: The I/Os of the STM32H5 series microcontroller are 3.3 V compatible instead of 5 V for ARDUINO® Uno V3.

Caution: R33 must be OFF before implementing the ARDUINO® shield with V_{REF+} power provided on CN7 pin 6.

NUCLEO-H563ZI pin assignments

Table 21. Zio connector (CN7) pinout

Zio pin	Pin name	Signal name	STM32 pin	STM32 function	Zio pin	Pin name	Signal name	STM32 pin	STM32 function
1	D16	I2S_A_MCK	PC6	I2S_2	2	D15	I2C_A_SCL	PB8	I2C1_SCL
3	D17	I2S_A_SD	PB15	I2S_2	4	D14	I2C_A_SDA	PB9	I2C1_SDA
5	D18	I2S_A_CK	PB13	I2S_2	6	VREFP	VREFP	-	VDDA/ VREFP
7	D19	I2S_A_WS	PB12	I2S_2	8	GND	GND	-	-
9	D20	I2S_B_WS	PA15	I2S_3	10	D13	SPI_A_SCK	PA5	SPI1_SCK
11	D21	I2S_B_MCK	PC7	I2S_3	12	D12	SPI_A_MISO	PG9	SPI1_MISO
13	D22	I2S_B_SD/ SPI_B_MOSI	PB5	I2S_3/SPI1	14	D11	SPI_A_MOSI/ TIM_E_PWM1	PB5	SPI1_MOSI/ TIM3_CH2
15	D23	I2S_B_CK/ SPI_B_SCK	PB3	I2S_3/SPI1	16	D10	SPI_A_CS/ TIM_B_PWM3	PD14	SPI1_CS/ TIM4_CH3
17	D24	SPI_B_NSS	PG10	SPI1	18	D9	TIM_B_PWM2	PD15	TIM4_CH4
19	D25	SPI_B_MISO	PB4	SPI1	20	D8	IO	PF3	-

1. For more details, refer to [Table 17. Solder bridge and jumper configuration](#).
2. PB13 is used as I2S_A_CK and connected to CN7 pin 5. If JP6 is ON, it is also connected to Ethernet PHY as RMII_TXD1. In this case, only one function of the Ethernet or I2S_A must be used.

Table 22. Zio connector (CN8) pinout

Zio pin	Pin name	Signal name	STM32 pin	STM32 function	Zio pin	Pin name	Signal name	STM32 pin	STM32 function
1	NC	NC	-	-	2	D43	SDMMC_D0	PC8	SDMMC1
3	IOREF	IOREF	-	3.3 V reference	4	D44	SDMMC_D1/ I2S_A_CKIN	PC9	SDMMC1/ I2S2_CKIN
5	NRST	NRST	NRST	Reset	6	D45	SDMMC_D2	PC10	SDMMC1
7	3V3	3V3	-	3.3 V input/ output	8	D46	SDMMC_D3	PC11	SDMMC1
9	5V	5V	-	5V output	10	D47	SDMMC_CK	PC12	SDMMC1
11	GND	GND	-	Ground	12	D48	SDMMC_CMD	PD2	SDMMC1
13	GND	GND	-	Ground	14	D49	IO	PG2	-
15	VIN	VIN	-	Power input	16	D50	IO	PG3	-

Table 23. Zio connector (CN9) pinout

Zio pin	Pin name	Signal name	STM32 pin	STM32 function	Zio pin	Pin name	Signal name	STM32 pin	STM32 function
1	A0	ADC	PA6	ADC12_INP3	2	D51	USART_B_SCLK	PD7	USART2
3	A1	ADC	PC0	ADC12_INP10	4	D52	USART_B_RX	PD6	USART2
5	A2	ADC	PC3	ADC12_INP13	6	D53	USART_B_TX	PD5	USART2
7	A3	ADC	PB1	ADC12_INP5	8	D54	USART_B_RTS	PD4	USART2
9	A4	ADC	PC2/ PB9	ADC12_INP12/ I2C1_SDA	10	D55	USART_B_CTS	PD3	USART2
11	A5	ADC	PF11/ PB8	ADC1_INP2/ I2C1_SCL	12	GND	GND	-	-
13	D72	IO	PB2	-	14	D56	SAI_A_MCLK	PE2	SAI1_A
15	D71	IO	PE9	-	16	D57	SAI_A_FS	PE4	SAI1_A
17	D70	I2C_B/SMBA	PF2	I2C2	18	D58	SAI_A_SCK	PE5	SAI1_A
19	D69	I2C_B_SCL	PF1	I2C2	20	D59	SAI_A_SD	PE6	SAI1_A
21	D68	I2C_B_SDA	PF0	I2C2	22	D60	SAI_B_SD	PE3	SAI1_B
23	GND	GND	-	-	24	D61	SAI_B_SCK	PF8	SAI1_B
25	D67	CAN_RX	PD0	CAN_1	26	D62	SAI_B_MCLK	PF7	SAI1_B
27	D66	CAN_TX	PD1	CAN_1	28	D63	SAI_B_FS	PF9	SAI1_B
29	D65	IO	PG0	-	30	D64	IO	PG1	-

Table 24. Zio connector (CN10) pinout

Zio pin	Pin name	Signal name	STM32 pin	STM32 function	Zio pin	Pin name	Signal name	STM32 pin	STM32 function
1	AVDD	AVDD	-	Analog VDD	2	D7	IO	PG12	IO
3	AGND	AGND	-	Analog GND	4	D6	TIMER_A_PWM1	PE9	TIM1_CH1
5	GND	GND	-	GND	6	D5	TIMER_A_PWM2	PE11	TIM1_CH2
7	A6	ADC_A_IN	PF12	ADC1_INP6	8	D4	IO	PE14	IO
9	A7	ADC_B_IN	PF13	ADC2_INP2	10	D3	TIMER_A_PWM3	PE13	TIM1_CH3
11	A8	ADC_C_IN	PF14	ADC2_INP6	12	D2	IO	PG14	IO
13	D26	QSPI_BCS	PG6	QSPI1_NCS	14	D1	USART_A_TX	PB6	LPUART1
15	D27	QSPI_CLK	PB2	QSPI1_CLK	16	D0	USART_A_RX	PB7	LPUART1
17	GND	GND	-	-	18	D42	TIMER_A_PWM1N	PE8	TIM1_CH1N
19	D28	QSPI_BK1_IO3	PD13	QSPI1_IO	20	D41	TIMER_A_ETR	PE7	TIM1_ETR
21	D29	QSPI_BK1_IO1	PD12	QSPI1_IO	22	GND	-	-	-
23	D30	QSPI_BK1_IO0	PD11	QSPI1_IO	24	D40	TIMER_A_PWM2N	PE10	TIM1_CH2N
25	D31	QSPI_BK1_IO2	PE2	QSPI1_IO	26	D39	TIMER_A_PWM3N	PE12	TIM1_CH3N
27	GND	GND	-	-	28	D38	TIMER_A_BKIN2	PE6	TIM1_BKIN2
29	D32	TIMER_C_PWM1	PA0	TIM2_CH1	30	D37	TIMER_A_BKIN1	PE15	TIM1_BKIN1
31	D33	TIMER_D_PWM1	PB0	TIM3_CH3	32	D36	TIMER_C_PWM2	PB10	TIM2_CH3
33	D34	TIMER_B_ETR	PE0	TIM4_ETR	34	D35	TIMER_C_PWM3	PA3	TIM2_CH4

13.2 ST morpho connector

The ST morpho connector consists of male-pin header footprints CN11 and CN12 (not soldered by default). They are used to connect the STM32H5 Nucleo-144 board to an extension board or a prototype/wrapping board placed on the top of the ST morpho. All signals and power pins of the STM32H5 are available on the ST morpho connector. An oscilloscope, logical analyzer, or voltmeter can also probe this connector.

Table 25 shows the pin assignments of each STM32H5 on the ST morpho connector.

Table 25. Pin assignment of the ST morpho connector

CN11 odd pins		CN11 even pins		CN12 odd pins		CN12 even pins	
Pin number	Pin name	Pin number	Pin name	Pin number	Pin name	Pin number	Pin name
1	PC10	2	PC11	1	PC9	2	PC8
3	PC12	4	PD2	3	PB8	4	PC6
5	VDD	6	5V_EXT	5	PB9	6	PC5
7	BOOT0	8	GND	7	VREFP	8	5V_STLK
9	PF6	10	NC	9	GND	10	PD8
11	PF7	12	IOREF	11	PA5	12	PA12
13	PA13	14	NRST	13	PA6	14	PA11
15	PA14	16	3V3	15	PA7	16	PB12
17	PA15	18	5V	17	PB6	18	NC
19	GND	20	GND	19	PC7	20	GND
21	PB7	22	GND	21	PA9	22	PB2
23	PC13	24	VIN	23	PA8	24	PB1
25	PC14	26	NC	25	PB10	26	PB15
27	PC15	28	PA0	27	PB4	28	PB14
29	PH0	30	PA1	29	PB5	30	PB13
31	PH1	32	PA4	31	PB3	32	AGND
33	VBAT	34	PB0	33	PA10	34	PC4
35	PC2	36	PC1	35	PA2	36	PF5
37	PC3	38	PC0	37	PA3	38	PF4
39	PD4	40	PD3	39	GND	40	PE8
41	PD5	42	PG2	41	PD13	42	PF10
43	PD6	44	PG3	43	PD12	44	PE7
45	PD7	46	PE2	45	PD11	46	PD14
47	PE3	48	PE4	47	PE10	48	PD15
49	GND	50	PE5	49	PE12	50	PF14
51	PF1	52	PF2	51	PE14	52	PE9
53	PF0	54	PF8	53	PE15	54	GND
55	PD1	56	PF9	55	PE13	56	PE11
57	PD0	58	PG1	57	PF13	58	PF3
59	PG0	60	GND	59	PF12	60	PF15
61	NC	62	PE6	61	PG14	62	PF11
63	PG9	64	PG15	63	GND	64	PE0
65	PG12	66	PG10	65	PD10	66	PG8

CN11 odd pins		CN11 even pins		CN12 odd pins		CN12 even pins	
Pin number	Pin name	Pin number	Pin name	Pin number	Pin name	Pin number	Pin name
67	NC	68	PG13	67	PG7	68	PG5
69	PD9	70	PG11	69	PG4	70	PG6

1. The default state of BOOT0 is 0. It can be set to 1 when a jumper is set [5-7] on CN11.
2. 5V_STLK is the 5 V power coming from the STLINK-V3EC USB connector that rises before and it rises before the +5 V rises on the board.
3. PA13 and PA14 are shared with SWD signals connected to STLINK-V3EC. ST does not recommend using them as I/O pins.

14 NUCLEO-H563ZI product information

14.1 Product marking

The stickers located on the top or bottom side of all PCBs provide product information:

- First sticker: product order code and product identification, generally placed on the main board featuring the target device.

Example:

Product order code Product identification

- Second sticker: board reference with revision and serial number, available on each PCB.

Example:

MBxxxx-Variant-yzz syywwxxxxx	
----------------------------------	-----------------------------------------------------------------------------------

On the first sticker, the first line provides the product order code, and the second line the product identification.

On the second sticker, the first line has the following format: “*MBxxxx-Variant-yzz*”, where “*MBxxxx*” is the board reference, “*Variant*” (optional) identifies the mounting variant when several exist, “*y*” is the PCB revision, and “*zz*” is the assembly revision, for example B01. The second line shows the board serial number used for traceability.

Parts marked as “*ES*” or “*E*” are not yet qualified and therefore not approved for use in production. ST is not responsible for any consequences resulting from such use. In no event will ST be liable for the customer using any of these engineering samples in production. ST’s Quality department must be contacted prior to any decision to use these engineering samples to run a qualification activity.

“*ES*” or “*E*” marking examples of location:

- On the targeted STM32 that is soldered on the board (for an illustration of STM32 marking, refer to the STM32 datasheet *Package information* paragraph at the www.st.com website).
- Next to the evaluation tool ordering part number that is stuck, or silk-screen printed on the board.

Some boards feature a specific STM32 device version, which allows the operation of any bundled commercial stack/library available. This STM32 device shows a “*U*” marking option at the end of the standard part number and is not available for sales.

To use the same commercial stack in their applications, the developers might need to purchase a part number specific to this stack/library. The price of those part numbers includes the stack/library royalties.

14.2 NUCLEO-H563ZI product history

Table 26. Product history

Order code	Product identification	Product details	Product change description	Product limitations
NUCLEO-H563ZI	NUH563ZI\$MR1	MCU:	Initial revision	Limitations linked to MCU silicon revision "Z"
		<ul style="list-style-type: none"> STM32H563ZIT6 silicon revision "Z" 		
		MCU errata sheet:		
		<ul style="list-style-type: none"> STM32H562xx/563xx/573xx device errata (ES0565) 		
		Board:		
		<ul style="list-style-type: none"> MB1404-H563ZI-C01 (main board) 		
	NUH563ZI\$MR2	MCU:	Updated MCU silicon revision	No limitation
<ul style="list-style-type: none"> STM32H563ZIT6 silicon revision "X" 				
MCU errata sheet:				
	<ul style="list-style-type: none"> STM32H562xx/563xx/573xx device errata (ES0565) 			
	Board:			
	<ul style="list-style-type: none"> MB1404-H563ZI-C01 (main board) 			

14.3 Board revision history

Table 27. Board revision history

Board reference	Board variant and revision	Board change description	Board limitations
MB1404 (main board)	H563ZI-C01	Initial revision	No limitation

15 Federal Communications Commission (FCC) and ISED Canada Compliance Statements

15.1 FCC Compliance Statement

Part 15.19

This device complies with Part 15 of the FCC Rules. Operation is subject to the following two conditions: (1) this device may not cause harmful interference, and (2) this device must accept any interference received, including interference that may cause undesired operation.

Part 15.21

Any changes or modifications to this equipment not expressly approved by STMicroelectronics may cause harmful interference and void the user's authority to operate this equipment.

Part 15.105

This equipment has been tested and found to comply with the limits for a Class B digital device, pursuant to part 15 of the FCC Rules. These limits are designed to provide reasonable protection against harmful interference in a residential installation. This equipment generates uses and can radiate radio frequency energy and, if not installed and used in accordance with the instruction, may cause harmful interference to radio communications. However, there is no guarantee that interference will not occur in a particular installation. If this equipment does cause harmful interference to radio or television reception which can be determined by turning the equipment off and on, the user is encouraged to try to correct interference by one or more of the following measures:

- Reorient or relocate the receiving antenna.
- Increase the separation between the equipment and receiver.
- Connect the equipment into an outlet on circuit different from that to which the receiver is connected.
- Consult the dealer or an experienced radio/TV technician for help.

Note: Use only shielded cables.

Responsible party (in the USA)

Terry Blanchard
Americas Region Legal | Group Vice President and Regional Legal Counsel, The Americas
STMicroelectronics, Inc.
750 Canyon Drive | Suite 300 | Coppel, Texas 75019
USA
Telephone: +1 972-466-7845

15.2 ISED Compliance Statement

ISED Canada ICES-003 Compliance Label: *CAN ICES-3 (B) / NMB-3 (B)*.

Étiquette de conformité à la NMB-003 d'ISDE Canada: *CAN ICES-3 (B) / NMB-3 (B)*.

Revision history

Table 28. Document revision history

Date	Revision	Changes
24-Feb-2023	1	Initial release.
04-Aug-2023	2	Updated: <ul style="list-style-type: none">• PA15 replaced by PA5 on SPI1_SCK MCU signal in Table 21• New product identification including MCU silicon revision in Table 26

Contents

1	Features	2
2	Ordering information	3
2.1	Products and codification	3
3	Development environment	4
3.1	System requirements	4
3.2	Development toolchains	4
3.3	Demonstration software	4
4	Conventions	5
5	Quick start	6
5.1	Getting started	6
6	Hardware layout and configuration	7
6.1	STM32H5 Nucleo-144 board layout	8
6.2	Mechanical drawing	10
7	Embedded STLINK-V3EC	11
8	Power supply	14
8.1	Power supply input from STLINK-V3EC USB connector: 5V_STLK (default configuration)	14
8.2	External power supply input from VIN (7 to 12 V, 800 mA maximum)	15
8.3	External power supply input 5V_EXT (5 V, 1.3 A maximum)	15
8.4	External power supply input from a USB charger (5 V)	16
8.5	External power supply input from the USB user connector (5 V, 3 A maximum).....	17
8.6	External power supply input 3V3_EXT (3.3 V, 1.3 A maximum)	18
8.7	Debugging/programming when not using an external power supply	18
9	Clock sources	19
9.1	HSE clock (high-speed external clock).....	19
9.2	LSE clock (low-speed external clock): 32.768 kHz	19
10	Board functions	20
10.1	LEDs.....	20
10.2	Push-buttons	20
10.3	MCU voltage selection 1V8/3V3	21
10.4	Current consumption measurement (IDD)	21
10.5	Virtual COM port (VCP): LPUART1/USART3	21
10.6	USB Type-C® FS.....	22
10.6.1	USB FS device	22
10.6.2	UCPD	22

10.7	Ethernet	23
11	Solder bridges and jumpers.....	24
12	Board connectors	28
12.1	STLINK-V3EC USB Type-C [®] connector (CN1)	28
12.2	User USB Type-C [®] connector (CN13)	29
12.3	Ethernet RJ45 connector (CN14)	29
13	Expansion connectors	31
13.1	ST Zio connectors	31
13.2	ST morpho connector	34
14	NUCLEO-H563ZI product information	36
14.1	Product marking	36
14.2	NUCLEO-H563ZI product history	37
14.3	Board revision history	37
15	Federal Communications Commission (FCC) and ISED Canada Compliance Statements	38
15.1	FCC Compliance Statement	38
15.2	ISED Compliance Statement	38
	Revision history	39
	List of tables	42
	List of figures.....	43

List of tables

Table 1.	Ordering information	3
Table 2.	Codification explanation	3
Table 3.	ON/OFF convention	5
Table 4.	Default jumper configuration	6
Table 5.	JP1 configuration	12
Table 6.	MIPI20 debug connector (CN5) pinout	12
Table 7.	External power sources VIN (7 to 12 V)	15
Table 8.	Power supply input from 5V_EXT (5 V, 1.3 A)	15
Table 9.	External power source CHGR (5 V)	16
Table 10.	External power source USB user (5 V, 3 A)	17
Table 11.	External power source 3V3_EXT (3.3 V, 1.3 A maximum)	18
Table 12.	USART3 connection	21
Table 13.	LPUART1 connection	21
Table 14.	Hardware configuration for the USB interface	22
Table 15.	Hardware configuration for the UCPD feature	23
Table 16.	Ethernet pin configuration	23
Table 17.	Solder bridge and jumper configuration	24
Table 18.	STLINK-V3EC USB Type-C® connector (CN1) pinout	28
Table 19.	User USB Type-C® connector (CN13) pinout	29
Table 20.	Ethernet connector (CN14) pinout	30
Table 21.	Zio connector (CN7) pinout	32
Table 22.	Zio connector (CN8) pinout	32
Table 23.	Zio connector (CN9) pinout	33
Table 24.	Zio connector (CN10) pinout	33
Table 25.	Pin assignment of the ST morpho connector	34
Table 26.	Product history	37
Table 27.	Board revision history	37
Table 28.	Document revision history	39

List of figures

Figure 1.	NUCLEO-H563ZI top view	1
Figure 2.	NUCLEO-H563ZI bottom view	1
Figure 3.	Hardware block diagram	7
Figure 4.	STM32H5 Nucleo-144 board top layout	8
Figure 5.	STM32H5 Nucleo-144 board bottom layout	9
Figure 6.	STM32H5 Nucleo-144 board mechanical drawing (in millimeters)	10
Figure 7.	Connecting an external debug tool to program the on-board STM32	12
Figure 8.	Power supply input from STLINK-V3EC USB connector with PC (5 V, 500 mA maximum)	14
Figure 9.	Power supply input from VIN (7 to 12 V, 800 mA maximum)	15
Figure 10.	Power supply input from 5V_EXT (5 V, 1.3 A maximum)	16
Figure 11.	Power supply input from STLINK-V3EC USB connector with a USB charger (5 V)	16
Figure 12.	Power supply input from USB user connector (5 V, 3 A)	17
Figure 13.	Power supply input from 3V3_EXT (3.3 V)	18
Figure 14.	USB Type-C® connector (CN1) front view	28
Figure 15.	USB Type-C® connector (CN13) front view.	29
Figure 16.	Ethernet RJ45 connector (CN14) front view	30
Figure 17.	STM32H5 Nucleo-144 board	31

IMPORTANT NOTICE – READ CAREFULLY

STMicroelectronics NV and its subsidiaries (“ST”) reserve the right to make changes, corrections, enhancements, modifications, and improvements to ST products and/or to this document at any time without notice. Purchasers should obtain the latest relevant information on ST products before placing orders. ST products are sold pursuant to ST’s terms and conditions of sale in place at the time of order acknowledgment.

Purchasers are solely responsible for the choice, selection, and use of ST products and ST assumes no liability for application assistance or the design of purchasers’ products.

No license, express or implied, to any intellectual property right is granted by ST herein.

Resale of ST products with provisions different from the information set forth herein shall void any warranty granted by ST for such product.

ST and the ST logo are trademarks of ST. For additional information about ST trademarks, refer to www.st.com/trademarks. All other product or service names are the property of their respective owners.

Information in this document supersedes and replaces information previously supplied in any prior versions of this document.

© 2023 STMicroelectronics – All rights reserved