



# SPL (HONG KONG) LIMITED

香港九龍觀塘鴻圖道57號南洋廣場17樓1703B室  
Room 1703B, 17/F., Nanyang Plaza, No.57 Hung To Road, Kwun Tong, Kowloon, HK.  
Tel: 852-2342 6857 / 2342 6867 Fax: 852-2342 6847 Email: sales@spl-hk.com.hk  
Website: www.buzzer.com.hk ; www.transducer.com.hk ; www.connector.com.hk



ISO 9001:2008  
Management  
System  
ID 9105074689

## Loud Speaker LSE77 Series

### DIMENSIONS

Date : 02 Jun.,2020

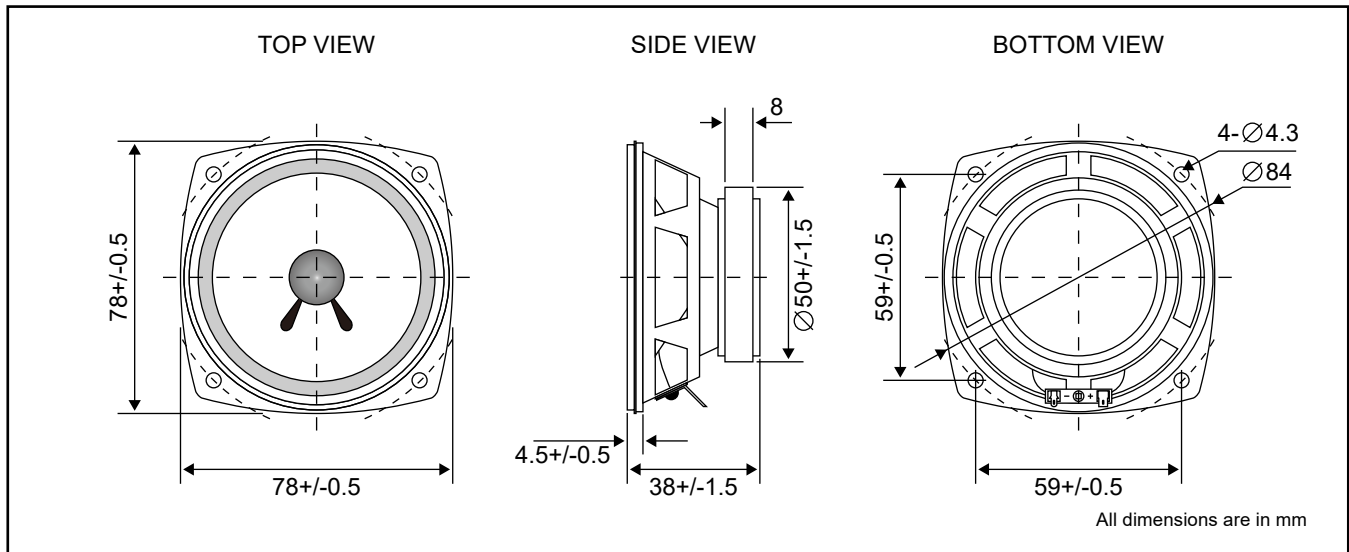

Ref. No. : P103718-R2



### ELECTRICAL SPECIFICATIONS

Model No.	LSE77-20R
Diameter	78 +/- 0.5 mm
Height	38 +/- 1.5 mm
Back Dia.	50 +/- 1.5 mm
Output S.P.L.	86 +/- 3 dB [ at 1.0W/0.5m, at 0.8K, 1.0K, 1.2K, 1.5K Hz ]
Impedance	8 ohm +/- 15%
Resonant Freq. [ Fo ]	160 Hz +/- 20%
Freq. Response	Fo ~ 15K Hz
Rated Input Power	7.0 W
Max. Input Power	14.0 W
Buzzer & Rattles	Must Be Normal [ Sine Wave 7.48 V, Fo ~ 5K Hz ]
Load Test	Must Be Normal [ White Noise 7.0 W, 96 Hours ]
Heat Test	Must Be Normal [ 60 +/- 3 °C, R.H. 96 Hours ]
Cold Test	Must Be Normal [ -20 +/- 3 °C, 96 Hours ]
Humidity Test	-40 +/- 2 °C, 90 ~ 95% R.H. 96 Hours
Case Material	Metal
Magnet	External Magnet
Operating Temperature	-20 ~ +60 °C
Weight	158 g