



# SPL (HONG KONG) LIMITED

香港九龍觀塘鴻圖道57號南洋廣場17樓1703B室  
Room 1703B, 17/F., Nanyang Plaza, No.57 Hung To Road, Kwun Tong, Kowloon, HK.  
Tel: 852-2342 6857 / 2342 6867 Fax: 852-2342 6847 Email: sales@spl-hk.com.hk  
Website: www.buzzer.com.hk ; www.transducer.com.hk ; www.connector.com.hk



ISO 9001:2008  
Management  
System  
ID 9105074689

## External Drive Piezo Transducer SPT49 series

### DIMENSIONS

Date : 15 May,2020

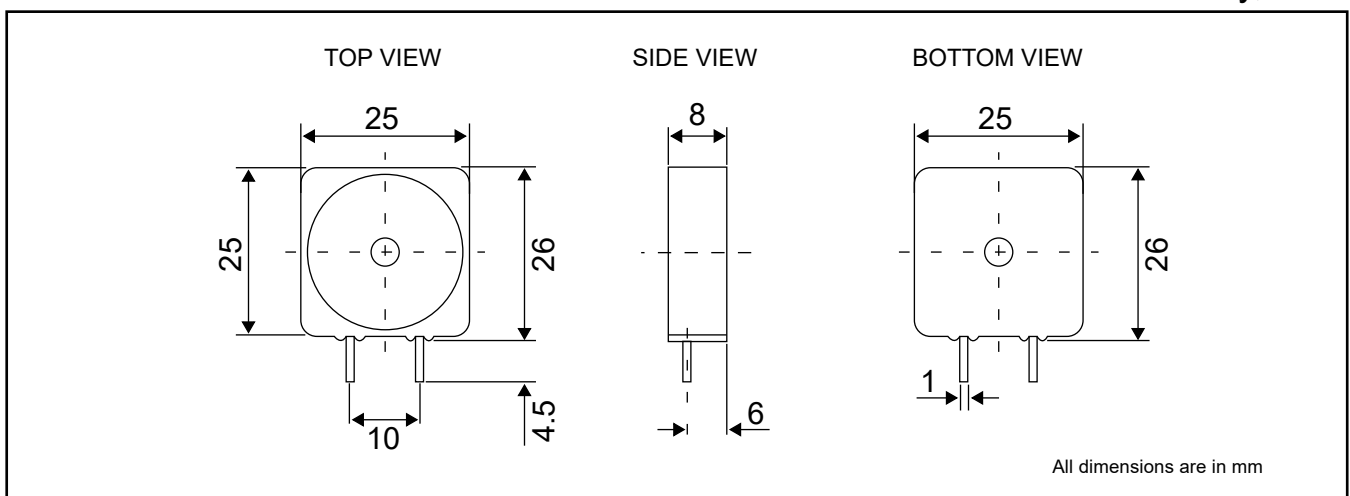

Ref no. : P125008-1R2



### ELECTRICAL SPECIFICATIONS

Model No.	PT49-250820PPR
Sound Pressure Level	85 dBA min. [8 Vp-p Square Wave, 10cm, 2000Hz]
Capacitance	22000 pF +/- 30% at 120Hz
Max. Input Voltage	30V p-p
Operating Temperature [°C]	-30 ~ +70
Storage Temperature [°C]	-40 ~ +80
Terminal	Pin
Housing Material	Nylon
Housing Colour	Black
Weight [gm]	5.5