

REVISIONS			
REV	DESCRIPTION	DATE	BY

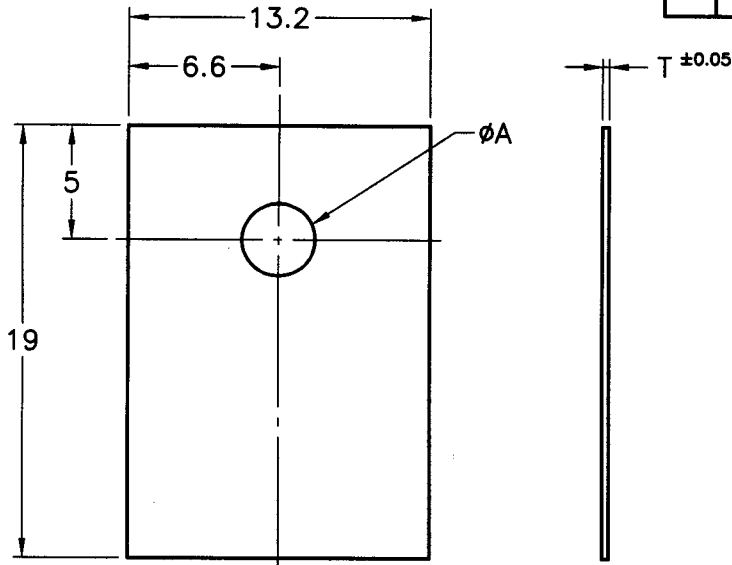

PART NO.	A	T
TO-220(.25)	3.2	0.25
TO-220	3.2	0.3
TO-220(.45)	3.2	0.45
TO-220(0.8)	3.2	0.8
TO-220S(.45)	2.5	0.45
TO-220L	4.0	0.3
TO-220(1.0)	3.2	1.0

QMFZ2 Component - Plastics

Friday, September 03, 2004

E153203

PIONEER CONDUCTOR RUBBER INDUSTRY CO LTD

WU KU INDUSTRIAL PARK, 4TH FL 99 WU KONG RD HSIN CHUANG TAIPEI HSIEN 242 TW

Material Designation: PMP-P-100

Product Description: Silicone Molding Resin (SIR), containing Sb203, furnished as sheets.

Color	Min. Thick. (mm)	Flame Class	HWI	HAI	RTI Elec	RTI Imp	RTI Str	IEC GWIT	IEC GWFI
ALL	0.15	V-0	-	-	150	150	150	-	-
NC, WT, BK	0.28	V-0	0	0	150	150	150	-	-
NC, BK	0.42	V-0	0	0	150	150	150	-	-
CTI: 0	IEC CTI: -	HVTR: 0			D495: 4				

Dielectric Strength (kV/mm): 20

Volume Resistivity (10<sup>10</sup>ohm-cm): 13

Dimensional Stability(%): 0.02

ISO Tensile Strength (MPa): -

ISO Flexural Strength (MPa): -

ISO Heat Deflection (C): -

ISO Tensile Impact (kJ/m<sup>2</sup>): -

ISO Izod Impact (kJ/m<sup>2</sup>): -

ISO Charpy Impact (kJ/m<sup>2</sup>): -

Report Date: 7/7/1993

Underwriters Laboratories Inc®

UL94 small-scale test data does not pertain to building materials, furnishings and related contents. UL 94 small-scale test data is intended solely for determining the flammability of plastic materials used in components and parts of end-product devices and appliances, where the acceptability of the combination is determined by ULL.

<p>康揚企業股份有限公司 KANG YANG HARDWARE ENTERPRISE CO., LTD. 東莞康揚塑膠五金電子廠 DONG GUAN KANG YANG PLASTIC HARDWARE COMPANY 康哲電腦配件(吳江)有限公司 KANG CHEE COMPUTER COMPONENTS(WUJIANG) CO.,LTD.</p>	TITLE		矽膠片		產品規格圖面		
	MATERIAL		SILICON UL94V-0		DATE		1998.08.15
	FINISH				DRAWN		JASON
	COLOR		GRAY		CHECK		陳明得
PART NUMBER	DRAWING NUMBER		UNLESS OTHERWISE SPECIFIED TOLERANCE		APPROVED		
SEE ABOVE	TO-220H		±0.5		Kang		
SIZE	SCALE	UNIT	REV				
A4	NONE	mm	B				